

GIBRALTAR IS

HARDWARE

STANDS

RACKS

PEDALS

SPARE PARTS

CUSTOM MOUNTING ACCESSORIES

2011



Gibraltar



GIBRALTAR IS HARDWARE

This undeniable focus makes us better at what we do and who we do it for. Touring pros depend on our racks, stands, and pedals. Many of the finest drum makers outfit their kits with Gibraltar Hardware – companies that are hard to please when it comes to quality and precision engineering, as you should be too. Because no matter what brand of kit you play Gibraltar supports them all. You see, Rock Solid isn't just our slogan. It's our mission.



Shown with **NEW** 9707ML-UA, **NEW** 6609NL and **NEW** GSVMS-DS
See pgs. 8, 13, 18 for details.



Shown with **NEW** Turning Point Hardware.
See pgs. 12, 43, 44 for details.



Shown with **NEW** 7700Q Quad Mount stands.
See pg. 16 for details



Rob Bourdon - Linkin Park

Table of Contents

Bass Drum Pedals

Intruder	4,5
Avenger	6
Prowler	7
Velocity	7

Hi-Hat Stands

Ultra Adjust	8
9000 Pro Dbl Braced	8
8000 Vintage Flat Base	9
6000 Heavy Dbl Braced	9
5000 Med Weight Dbl Braced	9
4000 Lgt Weight Dbl Braced	9
Hi-Hat Accessories	9

Thrones

9000 Series Pro Dbl Braced	10,11
7000 Series Elliptical Leg Base	11
6000 Moto Style	11
5000 Round Vinyl	11
3000 Compact	11
Roc-n-Soc Seats	11
Throne Seats, Bases, Accessories	10,11

Cymbal Stands

Turning Point	12
9000 Pro Dbl Braced	12
8000 Vintage Flat Base	12
6000 Heavy Dbl Braced	13
5000 Med Weight Dbl Braced	13
4000 Lgt Weight Dbl Braced	13

Snare Stands

9000 Ultra Adjust Dbl Braced / No Leg	14
8000 Vintage Flat Base	14
6000 Heavy Dbl Braced	15
5000 Med Weight Dbl Braced	15
4000 Lgt Weight Dbl Braced	15
Extended Height Snare Stands	15
No Leg Stand Mounting Arms	14

Specialty Stands

Electronic Mounting Stand	16
Specialty Tom Stands	16,17
Percussion Tables Workstations	17
Practice Pads and Sets	17

Racks

Stealth Vertical Mounting Systems	18
Mounting Systems	18,19
Stealth VMS Side Mounting Systems	19
Stealth Mounting Accessories	19
Road Series Racks	20
Road Series Rolling Drum Set Rack	21
Road Series Clamps and Accessories	22,23
Rolling Racks DCI	24,25
Mounting Accessories	23,25
Road Series Chrome	26,27
Rack Factory Basic Racks	28
Rack Factory Mounting Extensions	28
Rack Factory Starter Pack	26
Super Spanner Mounting System	29
Multi Purpose Rack	30,31
Power Rack Clamps	29
Hardware Bags	31

Percussion Stands

Conga Stands	32
Bongo Stands	32
Djembe Stands	33
Percussion Tables Workstations	33
Gong Stands and Accessories	33

Service Center

Accessories and Tuning	34
Drum Hoops and Suspension	35
Snare Drum / Tom Parts	36
Snare Drum Parts	37
Bass Drum Parts	38
Pedal Parts / Beaters	39
Tom Mounting	40,41
Tom Mounting Systems	42
Cymbal Arms / Mounting	43
Cymbal Arms / Attachments	44
Cymbal Stackers / Clamps	45
Cymbal Stand Parts	46
Hi-Hat Stand Parts and Accessories	47
Hand Percussion Mounting	48,49
Percussion / Mic Mounting	50
Supports / Accessories	51

Gibraltar Artists

Endorsee Roster	52,53
-----------------	-------



Jeremy Spencer - Five Finger Death Punch

Bass Drum Pedals

Nothing is more important than that right “feel” to your pedal. Gibraltar offers five series of pedals to fit your playing style and budget. Our Intruder Series is one of the industry’s finest and most reliable pedals, featuring cam, direct drive and sprocket drives. The Avenger Series utilizes the same cam drive system as the Intruder, with simpler execution while the clean and simple feel of our Prowler and Velocity Series offer unmatched speed and value.

9000 SERIES INTRUDER

Gibraltar’s Intruder pedals give you three drive options to best suit your technique and playing style.

Intruder Features:

- Pedal board height adjustment independent of spring tension or beater angle
- Fast rocker hub spring assembly with bearing spring hook
- Aluminum Rock stabilizer plate with tool kit
- Dual Surface, balanced, self-aligning beater with non-slip memory lock mechanism (Pat no 117,437)
- Case hardened U-joints on double pedals
- Includes fully padded carrying bag

Top Adjustable
Hoop Mount



Dual Chain Drive Cam



Direct Drive Cam



Strap Drive Cam



9611DC Dual Chain Drive Single Pedal

Dual Chain Cam gives a solid,
powerful feel.



9611DC-DB Dual Chain Double Pedal





9611DD
Direct Drive Single Pedal
 Patented Direct Drive System
 delivers seamless, fast response.



9611DD-DB
Direct Drive Double Pedal



9611SD
Strap Drive Single Pedal
 Strap Drive is like playing on air,
 a simple, fast feel. Features a
 durable Kevlar strap.



9611SD-DB
Strap Drive Double Pedal



All Intruder pedals come with a fully padded carrying bag for easy transport. Just remove the beaters and you're ready to go. Bags have accessory pockets for beaters, tools, and extra parts. Bags also available separately. 14 1/2" L x 10 1/2" W x 7" H

GSPCB Single Pedal Bag
GDFCB Double Pedal Bag

Tool Kit,
 Aluminum Rock Plate



Independently adjustable
 beater angle and
 pedal board height



Stefanie Eulinberg - Kid Rock

Bass Drum Pedals

6000 SERIES AVENGER

Delivers fast, solid, double Cam action with simple execution. Single pedals have two bearings per drive system; four on double pedals. Easy key access adjustable hoop clamp, adjustable spring tension and Rock stabilizer plates with Velcro® base give a solid balanced feel.

Avenger Features:

- Double chain Cam drive system
- Two bearings per drive
- Easy key access hoop clamp
- Adjustable spring tension
- Rock stabilizer plates with Velcro®
- Self-aligning beater
- Case hardened U-joints on double pedals

6611
Avenger Single Pedal

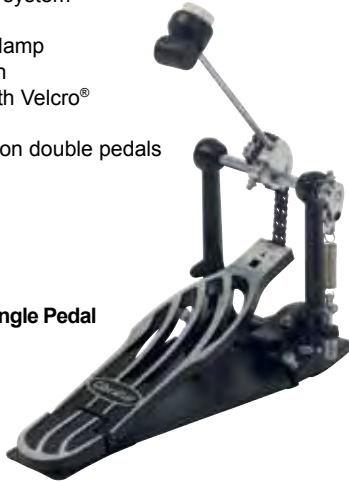

6611-DB
Avenger Double Pedal



5000 SERIES PROWLER

Designed to be clean and simple with quick response.
Single chain Cam drive action gives fast response in a simple design.

Prowler Features:

- Single chain Cam drive system
- Rocker hub with hook and bearing
- Easy key access hoop clamp
- Rock stabilizer plate with Velcro®
- Dual surface beater

Double Pedal Features:

- Rock stabilizer plate on slave pedal
- Hardened steel universal connecting rod

5611
Prowler Single Pedal

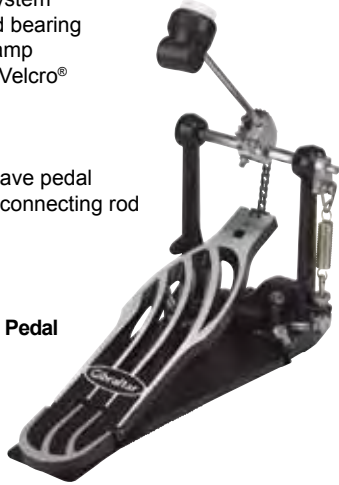

5611-DB
Prowler Double Pedal



NEW

4000 SERIES VELOCITY

The Velocity Chain Drive single bass drum chain drive pedal is a simple and fast pedal, styled with the Wave pedal board and hammer dual surface beater this pedals delivers speed and ease of use.

Velocity Chain Drive Features:

- Fast and solid single chain drive
- Wave pedal board design
- "Hammer" style Dual Surface beater
- Adjustable spring tension
- Sturdy all cast pedal frame

4611
Velocity Chain Drive Single Pedal



3000 SERIES VELOCITY

Gibraltar's Velocity Strap Drive single and double bass drum pedals are down and dirty pedals designed to be straightforward and fast.

Velocity Features:

- Kevlar® non-stretch strap drive system
- Wave pedal board design
- Dual Surface beater
- Adjustable spring tension
- Lightweight, sturdy powder coated frame

Double Pedal Features:

- Rock stabilizer plate on slave pedal
- Hardened steel universal connecting rod

3311S
Velocity Strap Drive Single Pedal



3311-DB
Velocity Double Pedal



Hi-Hat Stands

The Hi-Hat stand is the centerpiece of the drum setup. Feel, stability, and easy placement are important needs of the drummer. Gibraltar meets these needs by offering two drive systems for two distinctively different feels and many stand base options to give drummers flexibility in stand placement and image style. Gibraltar gives you "nothing but options" when building or customizing your drum setup.

ULTRA ADJUST

Gibraltar's Ultra Adjust hi-hat stand allows the player to position the stand in a comfortable leg playing position and independently position the hi-hat cymbals for best playing placement. Gibraltar accomplished this utilizing the patented Ultra Adjust system. These two gearless positioning points give up to eight inches displacement for the upper stand section of the hi-hat.

Ultra Adjust Hi-Hat Features:

- Ultra Adjust hi-hat cymbal positioning
- Liquid Drive system for balanced action
- Playing height adjusts from 33" to 38"
- Step Tension Adjustment
- Moveable leg base rotates 360 degrees to accommodate multi pedal setups
- No Leg base model option for extra clean placement
- Removable upper pull rod



Reinforced Cable and Cable Housing now with height adjustment

NEW

9707ML-UA
Ultra Adjust
Moveable Leg
Hi-hat Stand
Height: 32" to 38"
Weight: 14.6 lbs
Tube Diameters:
1-1/8", 1"



NEW

9707NL-UA
Ultra Adjust
No-Leg
Hi-hat Stand
Height: 32" to 38"
Weight: 14.6 lbs
Tube Diameters:
1-1/8", 1"



No Leg Hi-hat Stand Mounting Accessories

SC-EA 100
Extension Arm
with adjustable
grabber clamp
Extends from 16" to 24"
12 3/4" down tube
Tube Diameter: 1"



SC-EA 200
Extension Arm
with ratchet super
grabber clamp
Extends from 13" to 25"

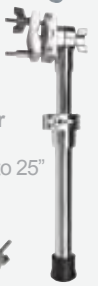

SC-EA 300
Ultra Adjust "Flex"
Extension Arm with
Super Grabber Clamps
and Length Adjustment
Extends from 22" to 28"



9000 SERIES

Gibraltar hi-hat stands are known for being smooth, fast and solid. The 9600 Series Hi Hats are offered in two drive systems with step tension adjustment, moveable and no leg bases options, with quick release rock stabilizer plates.

Features:

- Direct Lever Pull drive offers fast quiet action and direct response
- Liquid Drive provides a completely balanced action giving an equal tension feel for the down stroke and upstroke
- Step Tension adjustment allows the player to "dial in" correct tension

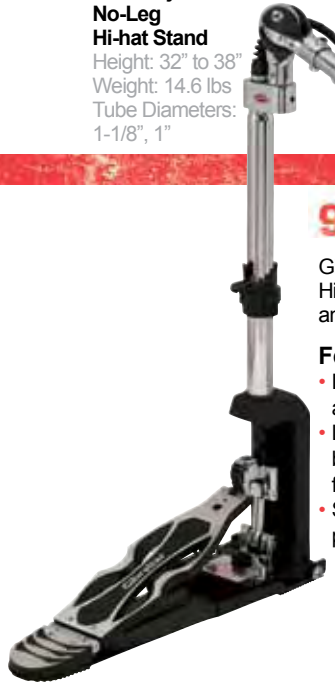

Liquid Drive
Highly Responsive Feel



Direct Lever Pull Drive
Clean Solid Action



9607NL-LD
No-Leg
Liquid Drive
Hi-hat Stand
Height: 29" to 37"
Weight: 12.4 lbs
Tube Diameters:
1-1/8", 1"

9607NL-DP
No-Leg
Direct Drive
Hi-hat Stand
(Not Shown)

9607DL-LD
Dual Leg
Liquid Drive
Hi-hat Stand
Height: 29" to 37"
Weight: 13.5 lbs
Tube Diameters:
1-1/8", 1"

9607DL-DP
Dual Leg
Direct Drive
Hi-hat Stand
(Not Shown)

9607ML-LD
Moveable Leg
Liquid Drive
Hi-hat Stand
Height: 29" to 37"
Weight: 14 lbs
Tube Diameters:
1-1/8", 1"

9607ML-DP
Moveable Leg
Direct Drive
Hi-hat Stand
(Not Shown)



8000 SERIES

Vintage flat base design gives a vintage look with top performance features. Key adjust tension adjustment, low mass leg base gives extra room for multi stand placement.

8607 Flat Base Hi-hat Stand

Height: 24" to 32"
Weight: 7 lbs
Tube Diameters:
7/8", 3/4"



6000 SERIES

Heavy weight double-braced tripod design with hinged height adjustment, cast frame, moveable leg base, and step tension adjustment.

6607 Heavy Weight Double-braced Hi-hat Stand

Height: 29.5" to 38"
Weight: 8.8 lbs
Tube Diameters:
1-1/4", 1"

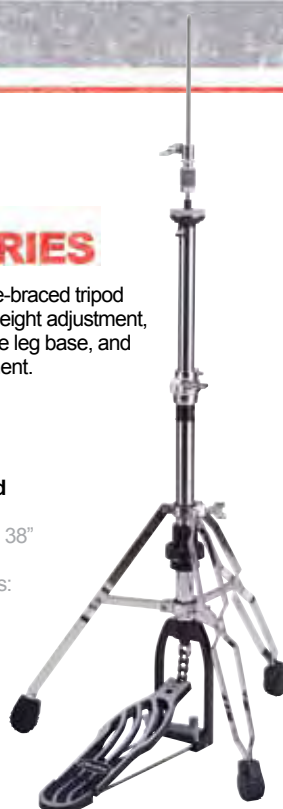

NEW

6607NL Heavy Weight No-Leg Hi-hat Stand

Height: 29.5" to 38"
Weight: 6.5 lbs
Tube Diameters:
1-1/4", 1"



5000 SERIES

Medium weight double-braced tripod base with key adjust tension, hinged height adjustment and cast frame with rotating leg base.

5607 Medium Weight Double-braced Hi-hat Stand

Height: 25" to 36"
Weight: 7.2 lbs
Tube Diameters:
1", 7/8"

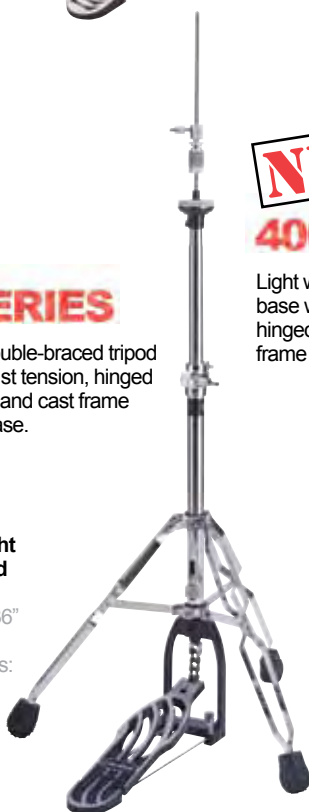

NEW

4000 SERIES

Light weight double-braced tripod base with key tension adjustment, hinged height adjustment and cast frame with rotating base.

4607 Light Weight Double-braced Hi-hat Stand

Height: 25" to 36"
Weight 6.8 lbs
Tube Diameters:
5/8", 3/4"



SC-HHOTPK

Gibraltar's SC-HHOT Hi-Hat Off Time Attachment mounts to your existing hi-hat stand adding an additional layer of rhythm to your sound. This attachment adds a second set of hi-hats to any brand of hi-hat, giving you a "chik" sound on the off beat when keeping time with your hi-hat foot. This really fills your sound out for all styles and grooves. Includes "Chik Hats"



NEW

SC-XHHR

X-hat on Boom Rod
12.7mm boom rod mounts to stand with grabber clamp or mount to rack with SC-GRSRAA ratchet clamp



SC-XHAT
Hi-hat cymbal
tilter attachment
Fits onto
8mm cymbal tilter
to add hi-hat on
top of existing
cymbal (1pk)



9707XB

X-Hi-hat
Hi-hat attachment
with gearless brake
adjustment (1pk)



SC-GMP3MNT

iPod MP3 stand Mount
Mount your iPod or MP3 player
to any stand. Fits tube diameters
5/8" to 1-5/8". 9" gooseneck with
padded adjustable MP3 mount
with position lock and back-up
security tether.



NEW

Thrones

Being the driving force behind the band is anything but a cushy job. So to make what you do more comfortable, GIBALTAR offers more models of thrones than any other drum company. You select the throne of your choice or if you prefer, you can purchase a seat or a base separately. Giving you a greater selection and more options are what make Gibraltar thrones the leading brand in the market.

9000 SERIES

Features:

- Rock Solid double-braced base
- Super-lock cast seat tension system
- "Super Foot" solid foundation rubber feet
- Memory lock at height adjustment



9608VA
Workstation Throne
 Puts the drummer's important playing tools within easy reach. Includes Velcro mounted stick holder, accessory / cup holder, and players towel that can be mounted anywhere on the seat side panels for easy access
 Adjusts: 20" to 27"
 Seat Dimensions:
 13 3/4" round
 3 1/2" tall



9608
Round Vinyl Seat
 Adjusts: 20" to 28"
 Seat Dimensions:
 13 3/4" round
 3 1/2" tall



9608SFT
Softy Throne
 5" Thick Super Soft Seat
 Adjusts: 21" to 30"
 Seat Dimensions:
 13 3/4" round
 5" tall



9608HM
Hydraulic Throne
 Features a 17" plush Cordura Moto style seat with easy-to-use lever hydraulic height adjustment
 Adjusts: 19.5" to 26"
 Seat Dimensions:
 17 1/4" wide
 15 1/4" deep
 3 3/4" tall



9608M
Motorcycle Style Contoured Seat
 Adjusts: 20" to 28"
 Seat Dimensions:
 16 3/4" wide
 14 3/4" deep
 4 3/4" tall



9608D
Dome Throne
 Dome seat design incorporates ergonomic seating into your playing routine. The result is improved posture, balance, circulation and core strength
 Adjusts: 19 1/2" to 29"
 Seat Dimensions:
 13" round
 4 1/4" tall



9608OS
Oversized Motorcycle Seat with Extra Soft Foam
 Adjusts: 20" to 28"
 Seat Dimensions:
 18 3/4" wide
 15 3/4" deep

GUBR
Gibraltar Universal Back Rest Attachment
 The GUBR clamps to the post section of a standard throne and is adjustable in height for added back support. (Not compatible with hydraulic thrones)



GBR
Gibraltar Back Rest Attachment
 Fits 9608OS, 9608HM models

NEW

SC-GTFA
Gibraltar Throne Footrest Attachment
 Fits in between Gibraltar throne double leg brace and creates a convenient footrest.





9608MB
Oversized Motorcycle Seat
with Adjustable Backrest

Adjusts: 20" to 28"
Seat Dimensions:
16 3/4" wide
14 3/4" deep
3 3/4" tall

NEW



9608-2T
2-Tone Compact Saddle Seat

This saddle seat measures 16" wide by 13" deep, just enough size to give ultimate comfort to the player while being compact to carry.

Adjusts: 19.5" to 26"



B9608
Double-Braced Base

B9608S
Double-Braced Short Base
(Not Shown)

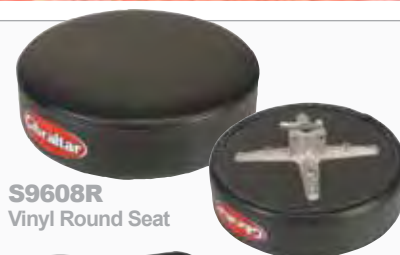

S9608R
Vinyl Round Seat



S9608OS
Oversized Moto Cycle Seat



S9608D
Dome Shaped Seat

GIBALTAR offers throne seats designed and manufactured by Roc-n-Soc USA. All seats fit into 7/8" diameter shafts. Each seat utilizes Roc-n-Soc's oversized design; premier foam and covering material providing years of solid support.

6000 SERIES



6608
Motorcycle Style Vinyl Seat

with memory lock height adjustment
Adjusts: 18" to 24"
Seat Dimensions:
15 1/2" wide
13 1/4" deep
3 3/4" tall

7000 SERIES



7708
Classic Elliptical Leg Base Throne

with memory lock height adjustment
Elliptical leg base performs like double brace without the weight
Adjusts: 17" to 26"
Seat Dimensions:
13 1/4" round
3 1/4" tall

5000 SERIES



5608
Round Vinyl Seat

Features Sturdy Single-Braced Tripod with memory lock height adjustment
Adjusts: 18" to 24"
Seat Dimensions:
13 1/4" round
2 1/4" tall

3000 SERIES



3308VA
Compact Accessory Throne

Includes Velcro mounted stick holder, accessory/cup holder, and player's towel
Adjusts: 17" to 26"
Seat Dimensions:
13 1/4" round
2 1/4" tall



RSGRC
Oversized Round Seat
Seat Dimensions:
15 1/2" round
3 1/2" tall



RSGRTC
Oversized Round Seat with Thigh cutouts
Seat Dimensions:
15 1/2" round
3 1/2" tall



RSGMC
Oversized Motorcycle Seat
Seat Dimensions:
17" wide
15" deep
3 1/4" tall

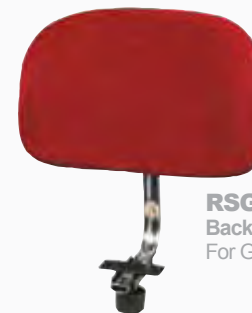

RSGBR
Backrest Attachment
For Gibraltar / Roc-n-Soc Seats

Cymbal Stands

Cymbal stands are a key element to any drum setup no matter if you are adding to an existing setup or building a new setup. Gibraltar leads the way with five series of cymbal stands to fit any playing situation. Each series provide unique features and innovations, while maintaining the high standards that are Gibraltar.



NEW

AWARD WINNING

Gibraltar's Turning Point Hardware was designed to solve two basic problems we hear about all the time.

- Stands are too heavy.
- Mounting cymbals with wing nuts takes time and is frustrating.

Weight: Gibraltar's Turning Point cymbal tripod base is made from chrome plated L-stock aluminum in a sleek arrow design. Gives the stability of double bracing but the weight of single braced-stand.

No wing nut; Gibraltar's patented Swing Nut auto cymbal tilter. Just press down on the spring loaded tilter turn the swing nut, mount the cymbal and felt and that's it, no wing nut to lose and you saves time.

Features:

- Patent Pending Swing Nut auto cymbal tilter with spring loaded cymbal adjustment
- Gibraltar's exclusive "Brake" style tilter adjustment gives gearless positioning with drum key lock for the tilter section
- Two-point hideaway boom with memory lock
- Re-designed "Super-Lock" hinged height adjustment with no metal-to-metal contact and wing nut adjust memory lock
- Cast collar tripod adjustment with nylon sleeve
- Round designed foot for solid foundation at any tripod position

9709TP Turning Point Boom Cymbal Stand

Hideaway boom
18' boom rod
Height: 29" to 65"
Weight: 9 lbs
Tube Diameters:
1-1/4", 1", 3/4"



New Light Weight L-Bar Aluminum Arrow Lite Leg Base"

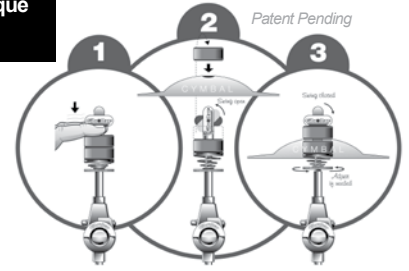

TURNING POINT SERIES

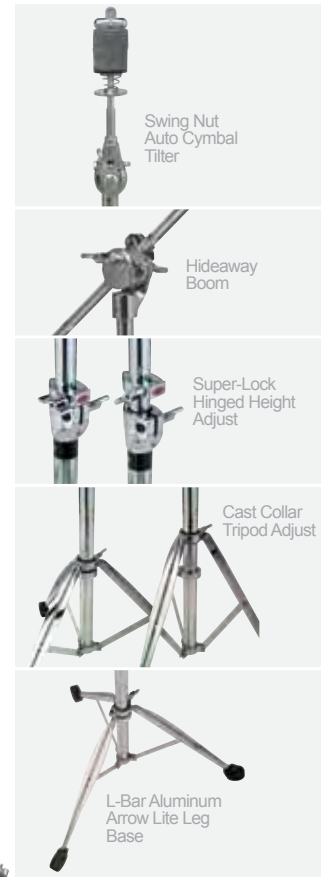

9710TP Turning Point Cymbal Stand

Height: 29" to 65"
Weight: 7 lbs
Tube Diameters:
1-1/4", 1", 3/4"



9000 SERIES

Professional Double-Braced Stands designed to be heavy duty, not heavy. Features include a low mass, collapsible parallel-braced leg base assembly; Super-Lock height adjustment mechanism with no metal-to-metal contact; hideaway boom casting, and brake style tilter.

Features:

- Low mass, collapsible parallel-braced leg base assembly
- "Super-Lock" height adjustment mechanism with no metal to metal contact
- Brake style tilter

9000 SERIES

9609-BT Boom Cymbal Stand with Brake Tilter

Hideaway boom
18' boom rod
Height: 29" to 65"
Weight: 12.4 lbs
Tube Diameters:
1-1/4", 1", 3/4"

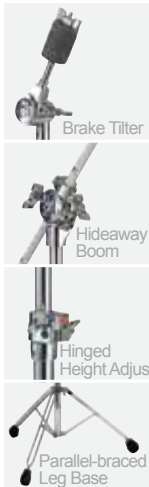
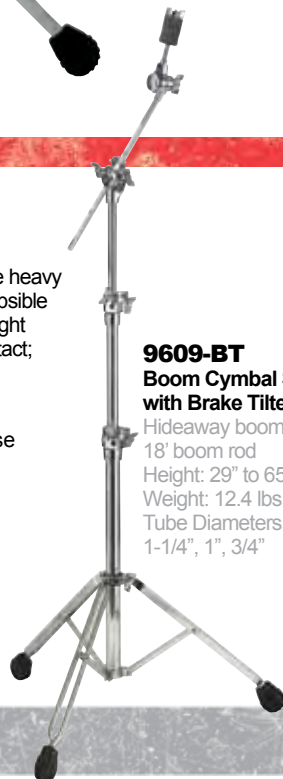

9610-BT Straight Cymbal Stand with Brake Tilter

Height: 29" to 65"
Weight: 10.2 lbs
Tube Diameters:
1-1/4", 1", 3/4"



8000 SERIES

Flat Base stands bring the classic flat base design with features for today's drummer. Low mass tripod with cast adjustments and Gibraltar's exclusive "Key Lock" that prevents any tripod movement. Hinged height adjustment with ABS inserts for no metal-to-metal contact and a gearless Brake Cymbal tilter with key memory lock.

Features:

- Classic look Tri-leg flat base with cast key lock
- Hinged height adjustments with ABS "Super Lock" inserts
- Hideaway boom casting
- Brake style gearless cymbal tilter with memory lock



8609
Flat Based
Boom Cymbal Stand
Hideaway boom
Height: 24" to 58"
Weight: 5.6 lbs
Tube Diameters:
7/8", 3/4"

8610
Flat Based
Straight Cymbal Stand
Height: 24" to 58"
Weight: 5.4 lbs
Tube Diameters:
7/8", 3/4"

8000 SERIES

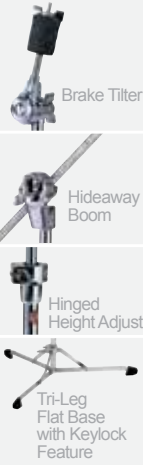

6000 SERIES

Professional in features yet light enough in weight and mass for easy transport. Double-braced tripod assembly provides maximum stability without heavy weight.

Features:

- 3-tier stand with hinged height adjustment
- Cast assemblies with ABS inserts



6609
Heavy Weight
Double-Braced
Boom Cymbal Stand
Height: 23" to 58"
Weight: 7.8 lbs
Tube Diameters:
1-1/4", 1", 7/8"

6610
Heavy Weight
Double-Braced
Straight Cymbal Stand
Height: 23" to 58"
Weight: 7.6 lbs
Tube Diameters:
1-1/4", 1", 7/8"

6000 SERIES

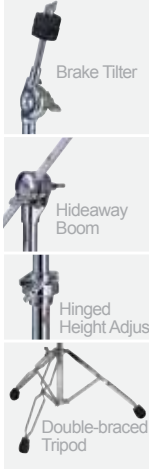

NEW

6609NL
Heavy Weight
No-Leg
Boom
Cymbal Stand
Height: 23" to 58"
Weight: 5 lbs
Tube Diameters:
1-1/4", 1", 7/8"

5000 SERIES

5000 Series stands utilize all professional features in a low-mass double-braced stand. Double-braced tripod with cast height assembly and Gibraltar's round rubber feet provide stability without a large profile.

Features:

- 3-tier stand with hinged height adjustment

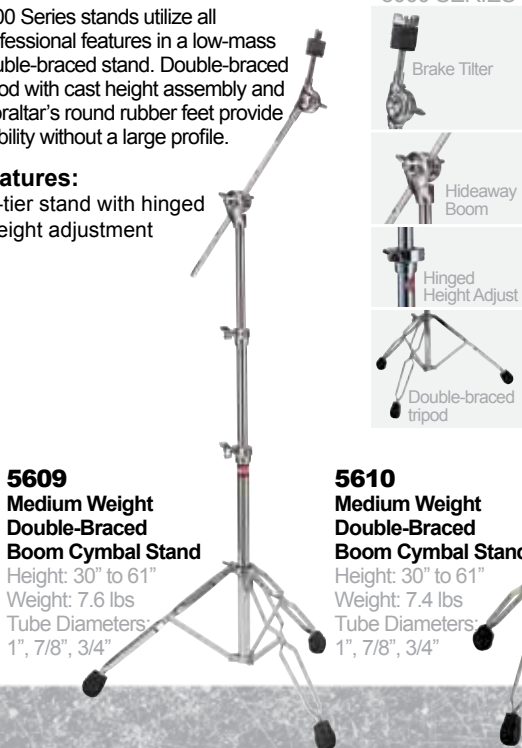

5609
Medium Weight
Double-Braced
Boom Cymbal Stand
Height: 30" to 61"
Weight: 7.6 lbs
Tube Diameters:
1", 7/8", 3/4"

5610
Medium Weight
Double-Braced
Boom Cymbal Stand
Height: 30" to 61"
Weight: 7.4 lbs
Tube Diameters:
1", 7/8", 3/4"

5000 SERIES

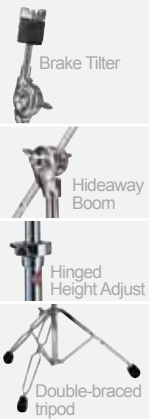

NEW

4000 SERIES

4600 Series stands feature low-mass double-braced construction featuring double-braced tripods, hinged height adjustment with nylon bushings for no metal-to-metal contact.

Features:

- Cast hinged height adjustment
- Low-mass double-braced tripods

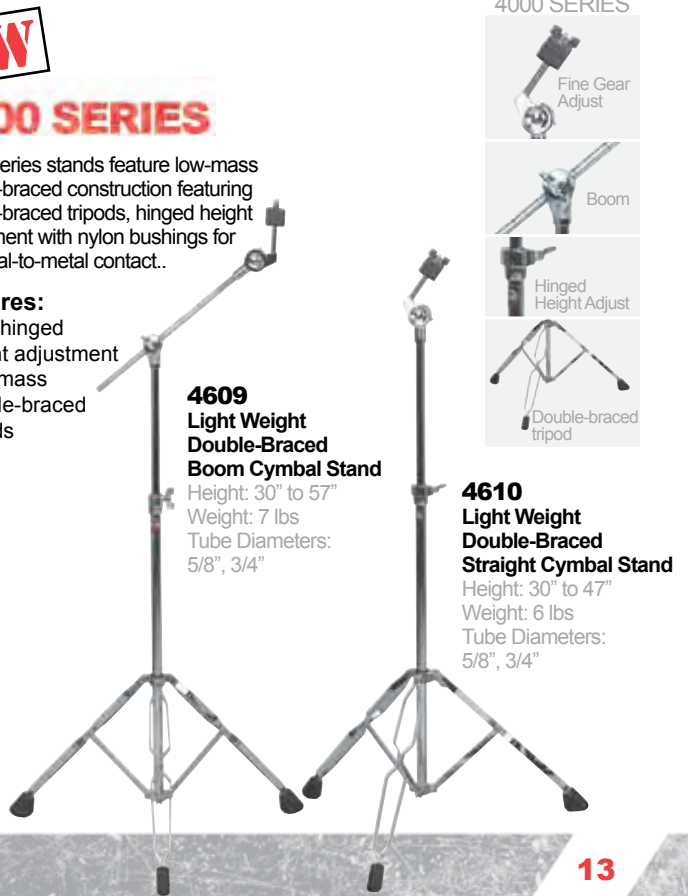

4609
Light Weight
Double-Braced
Boom Cymbal Stand
Height: 30" to 57"
Weight: 7 lbs
Tube Diameters:
5/8", 3/4"

4610
Light Weight
Double-Braced
Straight Cymbal Stand
Height: 30" to 47"
Weight: 6 lbs
Tube Diameters:
5/8", 3/4"

4000 SERIES

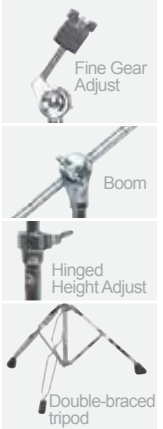

Snare Stands

Every drummer has a different style and different needs to fit that style. Gibraltar snare drum stands are designed to fit into any playing setup or situation with five series of stands to fit all styles and needs. Each series provide unique features and innovations, while maintaining the high standards that are Gibraltar.

9000 SERIES

Professional Double-Braced Snare Stands were designed to be heavy duty, not heavy. Features include a low mass, collapsible parallel-braced leg base assembly; Super-Lock height adjustment mechanism with no metal-to-metal contact.

Features:

- Low mass, collapsible parallel-braced leg base assembly
- "Super-Lock" height adjustment mechanism with no metal to metal contact
- Super Foot for solid support

No gears, just easy "Ultra" adjustment to get the exact snare basket position. Sturdy tripod base with Gibraltar's stabilizer super foot and hinged height adjustment with memory lock.



9606
Pro Ultra Adjustable Snare Stand
Adjusts 13 1/2" to 20"
Collapses to 16"
Weight: 9 lbs
Tube Diameters: 1-1/4", 1"



No Leg Snare Stand utilizes Gibraltar's Ultra Adjust basket adjustment with no leg base for rack and multi stand setups.

9606NL
Pro No Leg Ultra Adjust Snare Stand
Adjusts 16" to 28"
Collapses to 17"
Tube Diameters: 1-1/4", 1"



8606
Vintage Flat Base Snare Stand
Adjusts 15" to 24"
Collapses to 16"
Weight: 6 lbs
Tube Diameters: 7/8", 3/4"

8000 SERIES

Flat Base stands bring the vintage flat base design with features for today's drummer. Low mass tri-leg with cast adjustments and Gibraltar's exclusive "Key Lock" that prevents any tri-leg movement. Hinged height adjustment with ABS inserts for no metal-to-metal contact.

Features:

- Vintage look tri-leg flat base with cast key lock
- Hinged height adjustments with ABS "Super Lock" inserts
- Brake style gearless snare basket adjustment



Setup featuring 9606NL

No Leg Snare Stand Mounting Accessories

SC-EA 100
Extension Arm with adjustable grabber clamp
16" down tube
Diameter: 1"

SC-EA 200
Extension Arm with ratchet super grabber clamp
Extends from 13" to 25"

SC-EA 300
Ultra Adjust "Flex" Extension Arm with Super Grabber Clamps and Length Adjustment
Extends from 22" to 28"



Jim Riley - Rascal Flatts

6000 SERIES

Professional in features yet light enough in weight and mass for easy transport. Double-braced tripod assembly provides maximum stability without heavy weight.

Features:

- Medium weight tripod base with cast adjustment and captive threaded assembly
- Super lock height adjustment with ABS insert for no metal-to-metal contact
- Gibraltar's exclusive round rubber foot design stabilizes the stand at any position



6606
Heavy Weight
Double-braced
Snare Stand
 Adjusts 18" to 25"
 Collapses to 14"
 Weight: 6.4 lbs
 Tube Diameters:
 1-1/4", 1"

NEW

6000 Series No-Leg Stand

No-Leg snare stand works great in rack set ups.

Features:

- Super lock height adjustment with ABS insert for no metal-to-metal contact
- Fine gear basket adjustment



6606NL
Heavy Weight
No-Leg
Snare Stand
 Adjusts 18" to 25"
 Collapses to 14"
 Weight: 4 lbs
 Tube Diameters:
 1-1/4", 1"

5000 SERIES

Utilize all professional features in a low-mass double-braced stand. Double-braced tripod with cast height assembly and round rubber feet provide stability without a large profile.

Features:

- Low mass double-braced tripod base
- Super lock height adjustment with ABS insert for no metal-to-metal contact
- Gibraltar's exclusive round rubber foot design stabilizes the stand at any position



5606
Medium Weight
Double-braced
Snare Stand
 Adjusts 18" to 25"
 Collapses to 14"
 Weight: 6.4 lbs
 Tube Diameters:
 1", 7/8"

4000 SERIES

Professional features in a low mass light weight stand with all cast adjustment points.

Features:

- Low mass double-braced tripod base
- Fine gear basket adjustment
- Hinged height adjustment with nylon insert for no metal-to-metal contact



4606
Light Weight
Double-braced
Snare Stand
 Adjusts 16" to 24"
 Weight: 5.3 lbs
 Tube Diameters:
 5/8", 3/4"

EXTENDED HEIGHT SNARE STANDS



Features:

- Elliptical leg base
- Cast height adjustment
- Ultra Adjust positioning
- Holds 10" to 15" drums

7706EX
Elliptical Leg Base
Extended Height
Snare Stand
 Adjusts 25" to 41"
 Collapses to 29"
 Weight: 7.8 lbs
 Tube Diameters:
 1-1/4", 1"



Features:

- Stable large leg base
- Cast height adjustment
- Gearless offset basket tilter for exact placement
- Holds 10" to 15" drums

5606EX
Medium Weight
Extended Height
Snare Stand
 Adjusts 26" to 40"
 Collapses to 27"
 Weight: 8 lbs
 Tube Diameters:
 1", 7/8"

Specialty Stands

The needs of the percussionist are just as great as a set drummer. Which is why Gibraltar designed a complete and innovative line of stands and support hardware for concert, symphonic or any style of play.

GEMS Electronic Mounting Stand

Developed to give a solid mounting option for electronic components needed by today's musician. Great for drummers, guitar players, keyboard players, and DJ's.

16 1/2" mounting arms with adjustable rubber stoppers. Hinged height adjustment adjusts from 28" to 42". Folds for easy transport.

Tip- Use SC-GPRML Memory locks at clamping section.

SC-GEMC Electronic Mounting Arms with Clamp (pair)

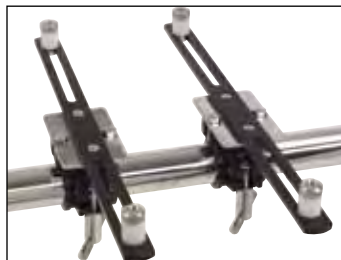

NEW

GEMS-TTOP Top Section

T-top only (SC-GEMC Arms not included).



GEMS shown with GEMAT



GEMAT Accessory Mounting Table with Folding Mount

12"x12" fiberglass table covered in black felt and clamps to vertical tube of GEMS or any stand. Table folds to an upright position for easy transport.



Folds for easy transport

NEW

SC-GMP3MNT iPod MP3 stand Mount

Mount your iPod or MP3 player to any stand. Fits tube diameters 5/8" to 1-5/8". 9" gooseneck with padded adjustable MP3 mount with position lock and back up security tether.



NEW

7700Q Quad Mount

Mounts two cymbal arms and two Ball L-rods (not included, see page 17)



7700Q shown with GEMS and Roland TD9 Electronic kit (not included)

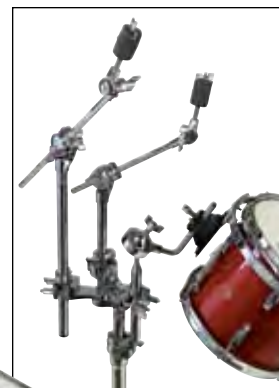

9613PM Double-Braced Adjustable 3-Mount Platform Stand

Many mounting options for the drummer and percussionist. Holds 3/4" diameter to 1-1/4" diameter arms. Adjusts from 26" to 41", collapses to 26"



Stands / Practice Pads

	SC-LBS Ball L-rod small 9.5mm		SC-BJEA Ball Extension Arm mount
	SC-LBM Ball L-rod medium 10.5mm		
	SC-LBL Ball L-rod large 12.7mm		
	SC-HBL Hex Style L-rod		



9813DP
Foundation Tripod Tom Stand with Cymbal Mount

Low profile 15-inch tripod base gives solid foundation when mounting heavy toms and cymbals. Uses Gibraltar SC ball L-rods available separately. Adjusts from 18" to 32" playing height.



7614
Double-Braced Concert Cymbal Stand

Holds two hand-held concert cymbals (up to 22" diameter) for quick easy access.



7615
Percussion Table on Double-Braced Stand

24"x24" padded table with tripod stand.



GPRWS
Percussion Workstation on Gibraltar Rack

Stands 60" tall by 36" wide with 24"x24" table and percussion mounts.

PRACTICE PADS



GP08
Practice Pad Kit on Gibraltar Rack

Practice Pad Kit Includes:
 (1) 20" horizontal bar
 (2) 20" vertical bars
 (4) GPRMC multi clamps
 (4) 8" rubber pads with mounting arms
 (3) GPRTC T-leg clamps
 (1) GBDP bass drum pad



GP05
Free Standing Practice Pad Kit

Built from an elliptical leg base assembly.
 Practice Pad Kit Includes:
 (4) 8" rubber practice pads with mounting arms
 (1) Rubber bass drum pad



SC-LPP
Leg Practice Pad with Strap
6" pad contoured fit with extra wide strap Velcro. Great for on-the-go practicing. (1pk)



GBDP
Bass Drum Practice Pad
10" Diameter

Gibraltar's air channel design for real bass drum feel. Three large spurs keep the GBDP securely on carpeted surfaces.

Mounting Systems

STEALTH VERTICAL MOUNTING SYSTEM

The STEALTH VMS showcases your drum kit and gives you a clean, uncluttered stage appearance... getting rid of bulky tripods and big rack bars running across your bass drum.

With the STEALTH System, you can create a low-profile "vertical mounting plane" for your toms and snare, creating a rock-solid foundation no matter how you like to setup your kit. The innovative mounting system works with virtually any kit configuration and uses your existing tom and snare mounting hardware regardless of which brand or size kit you play.

Now you can enjoy a clutter-free stage appearance like never before, with less to setup and less to carry when the gig is over.

Benefits of The STEALTH VMS:

- Low-profile, distinctive look really showcases your drum kit
- Versatile design works with any drum kit setup... from 4-piece to double bass
- Small footprint fits on any stage
- Accommodates double bass drum pedals and deep snare drums
- Allows for easy positioning unlike traditional racks that lock you in and don't move
- No Tripods! Creates a clean and uncluttered stage appearance
- Minimal hardware equals less weight to carry, easier setup and tear down
- Easy transport with the optional wheeled transport bag: just tear it down and wheel it out!



4-pc setup



1 up 2 down setup



Std 5-pc setup



5-pc
2 toms left
of Bass Drum
setup



6-pc
setup



Double Bass
setup



GSVMS
Stealth
Vertical Mounting System
Comes with 3/4", 7/8", and 1" adjustable sleeves to handle the tom mount and snare basket from most brands.



GSVMS-KIT
Stealth VMS Single Tom Kit
Comes with single tom mount and Ultra-Adjust snare basket included



GSVMS-DS
Stealth VMS Dual Snare Basket Kit
Stealth VMS Dual Snare Basket kit
GSVMS with two snare baskets

NEW

GSVMS-KIT Specs

- Tom / Cymbal vertical mounting post measures 18" from floor to mount
- Nylon sleeves accept 3/4", 7/8", and 1" diameter tom mounting or snare basket tube diameters
- Snare vertical mounting post measures 11" from floor to mount
- 30" bent connecting tube attaches tom and snare vertical mounting posts
- Bent section allows for low setting with double bass drum pedal
- Kit model includes single tom with 10.5mm and 12.7mm ball L-rod and Ultra adjust snare basket

STEALTH SIDE MOUNTING SYSTEM

The companion system to STEALTH handles cymbal and auxiliary percussion mounting. Comes with 3/4", 7/8", and 1" adjustable sleeves and utilizes all Gibraltar and other brand mounting hardware options.



GSSMS
Stealth Side Mount System



Custom set up using GSSMS



SC-GCRM
Chrome Multi-Clamp



SC-GCRA
Chrome Right Angle Clamp



SC-GPRCML
Chrome Memory Lock



SC-RMAADP
3/4", 7/8", and 1" adjustable nylon sleeves



SC-GPRSBAR
Stealth 30" Bent Bar



GUASB
Ultra Adjust Snare Basket
Positioning your snare drum exactly where you want it has never been easier than with Gibraltar's exclusive Ultra Adjustment.



SC-SPCM
Single Tom Platform with Cymbal Mount
Choose any Gibraltar mounting system to suit your kit setup style and brand specification.

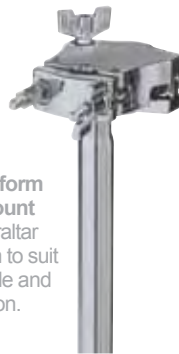

GSMTL
Stealth Mini T base with height adjustment
Mini T-leg for snare basket, great for adding no leg snare stand to drum kit.



GHTB
Hardware Transport Bag
32" bag with inset wheels makes it easy to transport your STEALTH rig from gig to gig.



Road Series Racks

There's no getting around it. Cymbal and tom stands have their limitations. Under heavy play, they can creep. Stand bases tend to get in the way of one another. Your setup never quite feels the same from gig to gig. And, as you know, there's a lot to tear down and haul around. Not so with Gibraltar's Road Series Rack Systems. Memory locks ensure that your drums and cymbals will be exactly where you want them. Always. There's no clutter on the stage floor. And, remarkably, without all those stand bases, there's actually less to transport.

GRS-850DBL

Just the rack system needed to provide double-bass players with setup flexibility at an affordable price. The GRS-850DBL takes up a minimum amount of space, yet it will accommodate a kit with as many as 6 toms and 8 cymbals. The GRS-850DBL also makes a great single-bass rack with side extension.

System Includes:

- (2) GRSTLA T-leg assemblies
- (1) GRSMTLA mini T-leg assembly
- (3) 36" vertical bars
- (2) 40" curved horizontal bars
- (4) GRSMC multi clamps
- (4) GRSHML hinged memory locks
- (10) GPRML memory locks
- (2) GRSRA right angle clamps
- (2) GRSSRA stackable right angle clamps
- (1) GRS-LOGO badge



GRS-850DBL
Curved Double-Bass Rack



Custom set up using GRS-850DBL
with custom parts

GRS-400C

The GRS-400C Basic Curved Bar Rack is Rock Solid yet portable. Fits up to a 24" bass drum. Perfect for a 5-piece drum kit or use the add-on side extension GRS-150C for extra options.

System Includes:

- (2) GRSTLA leg assemblies
- (2) 36" vertical bars
- (1) 46" curved horizontal bar
- (4) GRSMC multi clamps
- (4) GRSHML hinged memory locks
- (6) GPRML memory locks
- (2) GRSRA right angle clamps
- (1) GRS-LOGO badge



GRS-400C
Basic Rack with
Curved Front Bar

GRS-150C
Curved Right or
Left Side Extension

GRS-150C

System Includes:

- (1) GRSMTLA mini T-leg assembly
- (1) 36" vertical bar
- (1) 40" curved horizontal bar
- (1) GRSMC multi-clamp
- (1) GPRML memory lock
- (2) GRSRA right angle clamps
- (1) GRS-LOGO badge



Custom set up using GRS-400C
and 2 GRS-150C with custom parts



SC-RBA
Rack Cymbal Boom Attachment
Fits over any 1-1/2" diameter rack
tube and allows mounting of most
popular cymbal boom arms.

Road Series Rolling Rack

NEW
GRSRR

The GRSRR Drum Set Rolling Rack

- Fits any brand 5 piece drum set
- Hanging floor tom option
- Mount snare drum directly to rack (snare basket optional)
- 3' swivel casters

System Includes:

- (2) 3325B-1 Boom Arms
- (2) 30" vertical uprights with cymbal boom attachments and 3" rack casters with brakes and memory locks
- (1) 30" horizontal from bar
- (4) GRSMC Road Series Multi clamp
- (4) GRSHML Hinged Memory Locks
- (1) GRS-LOGO badge



SC-RC
Rack Caster
Converts T-leg assembly into moveable system.
3" wheel with brake.



GRSRR
Drum Set Rolling Rack



Custom set up using GRSRR



Shown above with optional Mounting Accessories

- (1) GRSMC Multi clamp
- (1) SC-LBBT Long Boom Cym Arm
- (1) 9707NL-DP No Leg Hi-Hat Stand
- (1) SC-GRSRA Right Angle Clamp
- (1) SC-GPRML Memory Lock
- (1) GLMP 14" extension tube (with adaptors)
- (1) GUASB Ultra Adjust snare basket
- (2) Tom Arm (model depends on brand see catalog for spec guide)
- (1) 6611 Bass Drum Pedal
- (1) Tom arm for hanging floor tom (see catalog for spec chart)
- (1) SC-GRSMC Multi Clamp
- (1) SC-SBBT Short Cym Boom Arm



Chris Adler - Lamb of God



Snare basket and no leg hi-hat can be mounted directly from rack for clean set-up.

Road Series

ROAD SERIES RACK CLAMPS AND ACCESSORIES

SC-GPRML

Memory Lock

1-1/2" diameter ensures same clamp position on rack bar. All metal construction. (2pk)



SC-GRSHML

Hinged Memory Lock

Can be added to rack without having to slide off other components. (1pk)



SC-GRSHKML

Hinged Key Memory Lock

Features drum key adjustment instead of wing key adjustment. (1pk) (Not pictured)

SC-GRSQS

Quick Set Clamp

Allows for two position (locking) angles which helps quicken setup and tear down. Primarily designed for use on horizontal bars and vertical leg bars.



SC-GRSAAC

Adjustable Angle Clamp

Secures two tubes and allows for angle adjustment.



SC-GRSTL

T-Leg Clamp

Designed for maximum support and stability of 90 degree T-leg assemblies.

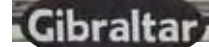

SC-GRSLOGO

Clip On Oval Rack Logo



SC-GPRLOGO

Clip On Rectangular Rack Logo

SC-GRSMC

Multi Clamp

For mounting toms, accessory arms (5/8" to 1-1/4" diameter) to standard 1-1/2" diameter rack tubes.



SC-GRSRAA

Ratchet Arm Multi Clamp



SC-GRSSMC

Super Multi Clamp

A larger multi clamping section with more gripping surface than the SC-GRSMC. For mounting heavy items.



SC-GRSAMC

Adjustable Multi Clamp



SC-GRSSRA

Stackable Right Angle Clamp

Allows two tubes to meet at the same horizontal angle and pivot up to 90 degrees on a vertical leg.



SC-GRSEMAC

End Mount Adjustable Multi Clamp



SC-GRSRA

Right Angle Clamp

Fixed 90 degree with hinged sides.



SC-GRSARA

Adjustable Right Angle Clamp



SC-GRSAR

Adjustable Right Angle Clamp

Similar in design to the SC-GRSRA. Allows multiple angle adjustments via a geared drum key rod/bolt assembly.



SC-GRSMAMC

Multi Angle Mutli Clamp

Similar in design to SC-GRSMC. Allows multiple angle adjustments via geared drum key rod/bolt assembly.



SC-RBA

Rack Cymbal Boom Attachment

Fits over any 1-1/2" diameter rack tube and allows mounting of most popular cymbal boom arms.



SC-RMAADP

3/4", 7/8", and 1" adjustable nylon sleeves



SC-RMAA

Rack Tube Attachment Mount

Fits over any 1-1/2" diameter rack tube and allows mounting of 3/4", 1/2" and 7/8" diameter cymbal, tom, and accessory arms.



SC-CBLMAN

Rack Cable Management Clips (2pk)



GPRSSA
Snare Stand Basket
 Snare basket section. Great for adding auxiliary drums to racks or stands.



GUASB
Ultra Adjust Snare Basket
 Positioning your snare drum exactly where you want it has never been easier than with Gibraltar's exclusive Ultra Adjustment positioning.

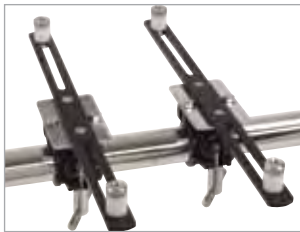

SC-GEMC
Electronic Mounting Arms with Clamp (pair)



SC-PCUT
Pipe Cutter
 Cut rack pipe to your custom length.



SC-RAT
Rack Adjustment Tool
 Adjusts T-handle, wing nut, and hex nuts on rack clamps.



SC-CBLMAN
Rack Cable Management Clips (2pk)

1-1/2" Diameter chrome steel tubes with plastic end caps

- SC-GPR20 20" Tube
- SC-GPR30 30" Tube
- SC-GPR36 36" Tube
- SC-GPR435 43.5" Tube
- SC-GPR59 59" Tube
- SC-GPR68 68" Tube



1-1/2" Diameter chrome steel tubes are bent at 15 degrees

- SC-GPR24C 24" Curved Tube
- SC-GPR30C 30" Curved Tube
- SC-GPR36C 36" Curved Tube
- SC-GPR40C 40" Curved Tube
- SC-GPR46C 46" Curved Tube



V-Style Bars

- SC-GPRSV 33" V-pipe
- SC-GPRLV 44" V-pipe

SC-GPRSBAR
Stealth 30" Bent Bar



SC-RC
Rack Caster
 Converts T-leg assembly into moveable system. 3" wheel with brake.



SC-GPRMFTL
Medium Fixed T-Leg Assembly
 12" fixed T-leg with 30" vertical tube.



SC-GPRSFTL
Standard Fixed T-Leg Assembly
 18" fixed T-leg with 30" vertical tube.



SC-GRSMTLA
Mini T-Leg Assembly
 12" long T-section. Excellent for tight spaces. Includes T-Leg Clamp.



SC-GRSTLA
Standard T-Leg Assembly
 20" long T-section. Includes T-Leg Clamp.



SC-RF/R
Round Rubber Feet
 Fits 1-1/2" rack tubes. (2pk)



SC-RF
Block Rack Feet
 Block style rubber foot for T-leg section. (2pk)



RF-TKIT
Tech Kit for Rack Building
 Includes level, wrench, drum key tool, gloves, towel and clip on logo.

Rolling Racks

Gibraltar's modular rack design works perfectly for Drum Corps multi-instrument stations giving unlimited mounting options. A 9" regulation locking caster is mounted directly to the rack, making the entire station mobile. Rack stations break down small for storage; and with all Gibraltar mounting accessory options, your set-up can change as needed. Build set-ups from Gibraltar's vast selection of rack parts and mounts or use the GRF rolling frame, GRF1T 1st tier and GRF2T 2nd tier pre-packaged racks.

NEW

GRF

GRF Gibraltar Rolling Frame

Pack Includes:

- (3) 30" rack tubes
- (12) GPRML memory locks
- (2) GRSTL T-leg clamps
- (4) GCASTER wheels

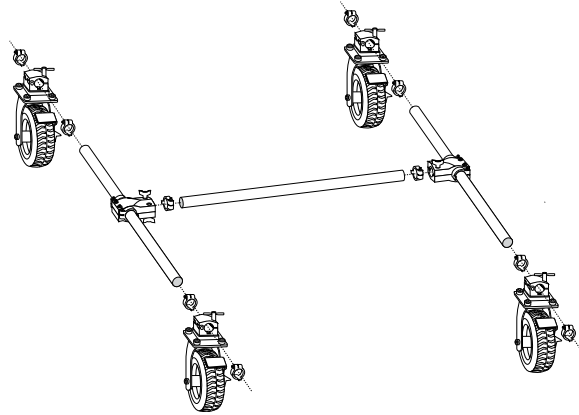
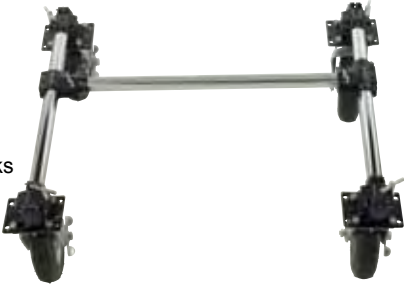

NEW

GRF1T

GRF1T Gibraltar Rolling Frame 1st Tier Rack

Pack Includes:

- (2) DMLP 30" posts with RMAA
- (1) SC-GPR46C 46" curved rack tube
- (4) GRSRA right angle clamps
- (4) GPRML memory locks

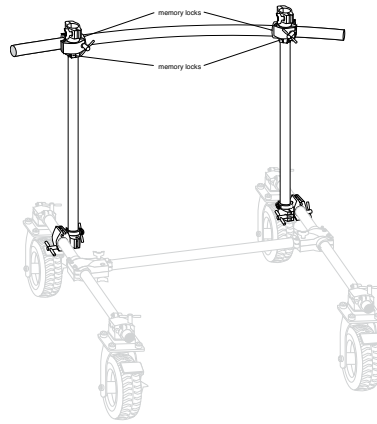
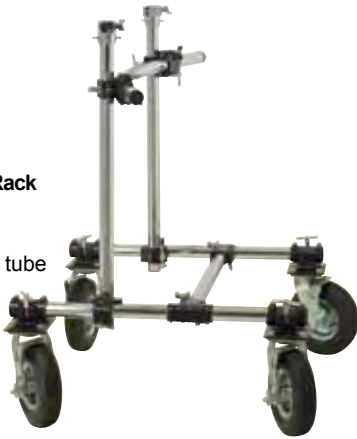

NEW

GRF2T

GRF2T Gibraltar Rolling Frame 2nd Tier Rack

Pack Includes:

- (4) 30" curved rack tubes
- (4) GRSRA right angle clamps
- (6) GPRML memory locks
- (2) RMAA attachment mounts

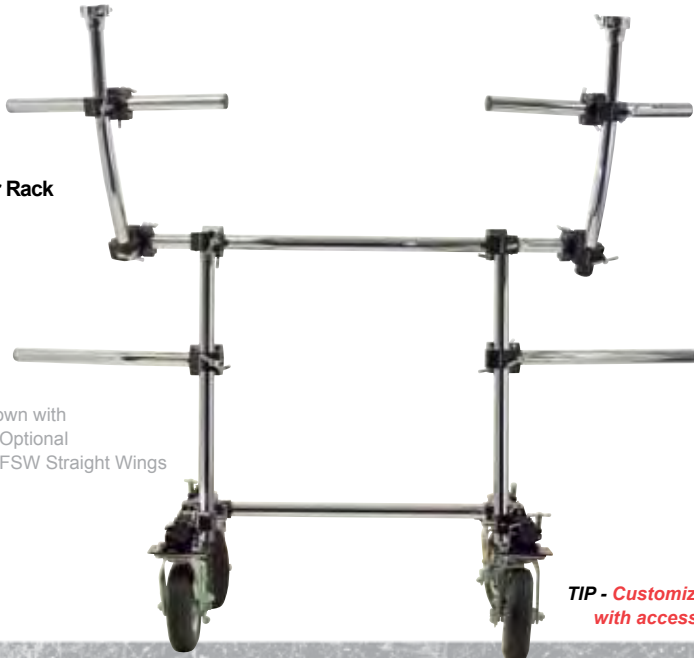

Shown with
(2) Optional
GRFSW Straight Wings

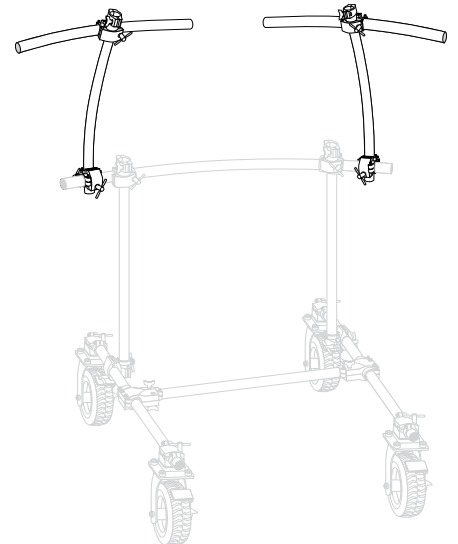

**TIP - Customize these prepack set ups
with accessories from pgs 23-24**



This station built with GRF + GRF1T and accessories



This station built with GRF + GRF1T + GRF2T + (2) GRFSW Straight Wings and accessories

ROLLING RACK ACCESSORIES - See pgs 22-23 for more mounting accessories

GLMP
Long 30" 1.5 Dia Post
w/Adaptors for 1", 7/8", 3/4"



GSMP
Short 14" 1.5"Dia Post
w/Adaptors for 1", 7/8", 3/4"



GDMNT
Djembe Stand
Top Section



GDMA
Djembe Mounting Arm



GDCM
Double
Conga Mount



NEW

SC-GDCHTK
Comfort Curved
High Torque Drum Key



GMAT
12x16 Percussion Table
Mounted Accessory Table (no lip)



GCASTER
9" Caster w/ brake and
full swivel adjustment



Road Series Chrome Racks

Introducing Gibraltar's new "Chrome" Road Series racks and clamp accessories. Chrome Road Series clamps have a new sleek design that takes some of the weight out of each clamp with high-luster chrome plating to give a one-of-a-kind look. Offering includes two rack models and an assortment of sleek designed chrome clamps.

GCS-450C

Four-post Road Series Rack with all curved horizontal bars wraps around the player giving ultimate placement for drums, cymbals, and mounting accessories. A great rack for single or double bass kit configurations.



GCS-450C

Chrome Series 4-post curved rack

Pack Includes:

- (1) SC-GPR46C 46" curved horizontal tube
- (2) SC-GPR36C 36" curved horizontal tubes
- (4) SC-GCRM C chrome multi clamps
- (4) SC-GCRML chrome memory locks
- (2) SC-GCSRA chrome stackable right angle clamps
- (4) 30" straight vertical bar mini T-legs
- (4) SC-RMAA rack mounting attachment clamps
- (1) GRS-LOGO badge

GCS-400C

Two-post Road Series Power Rack utilizes curved vertical bars and horizontal bars to give maximum placement options and image. Two curved wing extensions give additional mounting space for additional cymbals and mounted accessories.



GCS-400C

Chrome Series power rack with 2 curved wings

Pack Includes:

- (1) SC-GPR46C 46" curved horizontal tube
- (2) SC-GPR30C 30" curved vertical tubes w GCARA adjustable clamps
- (4) SC-GCRM C chrome multi clamps
- (4) SC-GCRML chrome memory locks
- (2) SC-GPR24C 24" curved bar wings
- (4) SC-GCRA chrome right angle clamp
- (1) GRS-LOGO badge



GCS-400CW
With Electronic drums



SC-CBLMAN
Rack Cable Management Clips (2pk)

ROAD SERIES CHROME CLAMPS

Sleek new design, Lighter weight than standard Road Series clamps, All Chrome one-of-a-kind look

SC-GCML

Chrome Series Memory Lock 2pk
Thinner design, all metal construction ensures clamp position on rack bar.



SC-GCHML

Chrome Series Memory Lock 1pk



SC-GCHKML

Chrome Series Hinged Memory Lock / Drum Key Adjust (not shown)
Thinner design takes up less space, hinge allows for easy placement. Drum key and wing nut adjustment options.

SC-GCRM

Chrome Series Multi Clamp
Multi clamp mounts 5/8" to 1-1/4" diameter accessory arms to 1.5" diameter rack bar.



SC-GCSMC

Chrome Series Super Multi Clamp
Same as SC-GCRM but features 2" of gripping space for secure mounting of heavier items.



NEW

SC-GCMAMC

Chrome Series Multi Adjustable Multi Clamp
Multi-clamp with geared drum key adjustable mount.



SC-GCRA

Chrome Series Right Angle Clamp
Connects two 1.5" diameter rack tubes to a fixed 90 degree angle.



SC-GCARA

Chrome Series Adjustable Right angle Clamp
Connects end of rack bar to another rack bar allowing for angle adjustment. Great for adding second bar to vertical upright or mounting vertical rack tube to T-leg with angle adjustment.



NEW

SC-GCSAR

Chrome Series Adjustable Right Angle Clamp
Mounts two 1 1/2" diameter rack tubes allowing for angle adjustments via geared drum key bolt assembly.

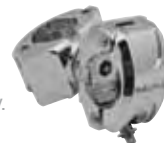

NEW

SC-GCSRA

Chrome Series Stackable Right Angle clamp
Allows two rack tubes to meet at the same horizontal angle and pivot up to 90 degrees on a vertical leg.



SC-GCEX

Chrome Series Rack Bar Extension Clamp
Connects two 1 1/2" diameter rack tubes end to end.



SC-GUATC

Chrome Series Ultra Adjust Tube Connector
Secures two rack tubes and with ultra adjustment allows for infinite angle adjustment.



SC-GRSCTL

Chrome T-Leg Clamp



Rack Factory Series

The Rack Factory Series is a professional rack best suited for stationary or situations where daily setup and tear down is not needed. The Rack Factory offering is made up of basic racks and rack add-on components that can be combined to build custom rack setups. Or you can choose the Rack Factory starter packs that have everything you need for the rack setup right in the box.



“BUILD IT THE WAY YOU WANT IT”

BASIC RACKS

Basic Racks are the foundation of the Rack Factory setup. This is the piece you build off of to create your rack system. Basic Racks come in two styles; Straight with straight front bar, and Curved style with curved front mounting bar.

BUILD YOUR OWN RACK

STEP 1: Choose your front rack



GSBR
Basic Straight Rack
43.5" wide
36" tall

GCBR
Basic Curved Rack
46" wide
36" tall



Vinnie Colaiuta - Independent

SIDE EXTENSIONS

Side Extensions have the same length mounting bar as Basic Racks. One side mounts to either side of a Basic Rack; the other side is supported with a vertical T-Leg base. This extension provides room to mount a myriad of drums, cymbals, and accessories.

BUILD YOUR OWN RACK

STEP 2: Choose your side(s)

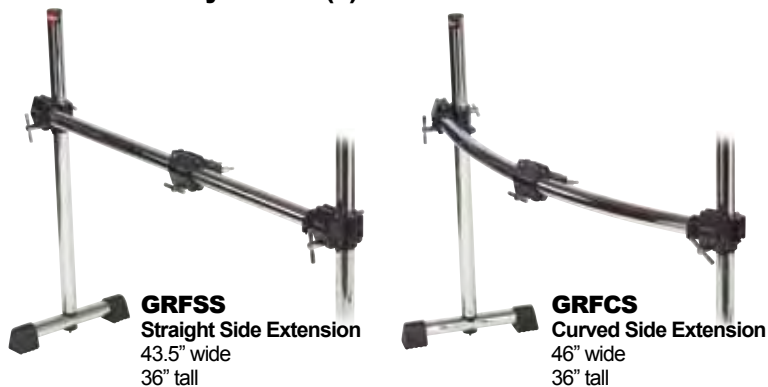

GRFSS
Straight Side Extension
43.5" wide
36" tall

GRFCS
Curved Side Extension
46" wide
36" tall

WING EXTENSIONS

Wing Extensions are great when you need a little more mounting space. Fly a wing off either side of your rack to mount extra drums or cymbals. Wings also come in three styles; Straight, Curved, and V-Style.

BUILD YOUR OWN RACK

STEP 3: Choose your wing(s)



GRFSW
Straight Wing Extension
24" wide

GRFCW
Curved Wing Extension
24" wide

STARTER PACK

Rack Factory Starter packs come with everything you need for your rack setup right in the box. Each rack system includes cymbal boom arms, clamps, and extensions needed to build the setup.



GRSP-CW
Curved Rack with Wings Starter Pack
46" wide, 36" tall, 24" wings

Pack Includes:

- (1) Basic Curved Rack with clamps
- (2) Curved Wings with clamps
- (2) Cymbal boom Arms with mounts

SUPER SPANNER SYSTEM



46" Curved rack bar connects to your existing cymbal stands via two SC-GRSSMC super multi-clamps.

GPR-SSS

Super Spanner System

Includes:

- (1) 46" curved rack bar
- (2) SC-GRSSMC super multi clamp
- (4) SC-GRSMC Road Series multi clamp
- (2) SC-GRSHML hinged memory lock
- (1) GRS-LOGO badge



SPANNER BAR

NEW



Mount more onto a cymbal stand with the SC-SPAN 7/8" Spanner Bar

SC-SPAN

Spanner Bar

Includes:

- (1) 7/8" Spanner Bar
- (3) SC-SMC clamps

SC-SMC
Spanner Multi Clamp
(Clamp only)



SC-SPAN shown with
SC-LBBT and SC-SBBT
cymbal arms



TIP - Use SC-HML Memory Lock with all clamps to hold position

POWER RACK CLAMPS

Choose from a wide offering of rack clamps and accessories to customize your setup.

SC-GPRML

Memory Lock

1-1/2" diameter ensures same clamp position on rack bar. All metal construction. (2 pk)



SC-GPRRA

Right Angle Clamp

Fixed right angle clamp with hinged sides. Joins two rack bars together at 90-degree angle.



SC-GPREX

Extension Clamp

Connects two 1-1/2" diameter rack tubes end-to-end.



SC-GPRMC

Multi Clamp

Universal clamp mounts to rack bar. Holds 5/8" to 1-1/4" diameter cymbal, tom or accessory arms.



SC-GPRTC

T-Clamp

Connects vertical tubing at 90-degree angle.



SC-GPRTL

T-Leg Clamp

Modified GPRTC designed for use in T-leg assemblies with key adjustments instead of wing nuts.



SC-GPRARA

Adjustable Right Angle Clamp

Allows many setup options. Mounts two rack bars at adjustable angles.



SC-GPRAC

Leg Angle Clamp

Connects rack tube to an angled hinge. Made of high impact plastic.



GMPR

Gibraltar

MULTI PURPOSE RACK



ACOUSTIC & ELECTRONIC DRUMS • KEYBOARDS • DJ EQUIPMENT • HOME RECORDING...

NOTHING
BUT
OPTIONS!

Gibraltar's Multi-Purpose, Power Rack has raised the bar and lowered the price, to allow more players to get involved in the world of racks. And not only drummers, this rack works for keyboard and home DJ's too. Includes instructional booklet that educates on rack set-up tips and tricks. Multiple uses using additional Gibraltar mounting accessories.

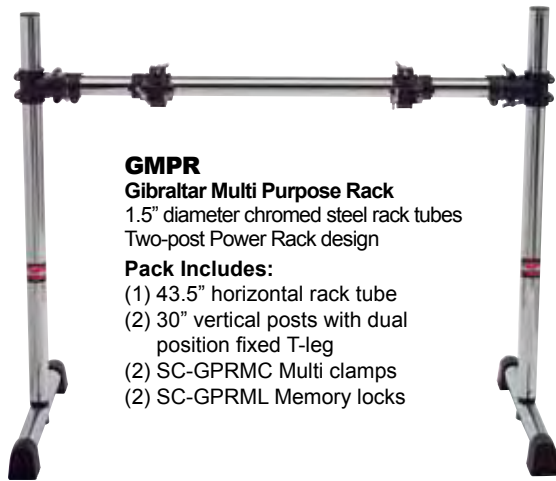

GMPR

Gibraltar Multi Purpose Rack

1.5" diameter chromed steel rack tubes
Two-post Power Rack design

Pack Includes:

- (1) 43.5" horizontal rack tube
- (2) 30" vertical posts with dual position fixed T-leg
- (2) SC-GPRMC Multi clamps
- (2) SC-GPRML Memory locks



GMPR
With Acoustic drums

- Acoustic set up accessories:
- (2) SC-DWLR L-Rod arms
 - (3) SC-GPRMC multi clamps
 - (3) SC-3325B-1 cymbal boom arms



DJ set up accessories:

- (1) SC-EA-100 grabber extension arm
- (1) GEMS-T top section
- (2) SC-GEMC mounting arms
- (1) GMAT folding accessory table

GMPR
With DJ Gear

Check out Gibraltarhardware.com
for more information on these set ups.



Kevin Hastings - Rihanna



GMPR
For Electronic drums
Shown with Roland TD9 Electronic Kit
(not included)

- Electronic set up accessories:**
- (8) SC-GPRMC multi clamps
 - (1) SC-EA-100 grabber extension arm
 - (2) SC-4425D-1 Tom L-rod 10.5mm arms
 - (1) SC-LRM 10.5mm L-rod
 - (2) SC-3325B-1 Cymbal boom arms



GMPR
With Keyboard

- Keyboard set up accessories:**
- (1) SC-EA-100 grabber extension arm
 - (1) SC-GEMC mounting arm

BAGS

GHTB
Hardware Transport Bag
32" bag with inset wheels makes it easy to transport your STEALTH rig from gig to gig.



GHLTB
Long Hardware Transport Bag
44" bag with inset wheels
This high test nylon bag has heavy-duty zippers with ABS perimeter reinforcements, rails on back panel with fold up side panels so it holds open when you insert stands.
Dimensions: 44" x 11" x 11"



NEW

GSSSB
Sling Style Stick Gig Bag
Sling style stick bag holds up to 6 pair sticks/mallets. Attaches to floor tom with plastic clip and has accessory pockets for keys, iPod, and accessories.



GRB
54" Rack Bag with ABS insert
Gibraltar's most popular rack bag. Fits most manufacturers' straight or curved bar rack systems.



GBH-S
Small Hardware and Accessories Bag with plastic inner lining.
Perfect for small stands; throne bases, snare stands or for various rack and stand attachments.
Dimensions: 32" x 11" x 11"



GBH-M
Medium Hardware and Accessories Bag
Perfect for stands of all types. Fits hi-hat stands without disassembling the upper section. Also fits Gibraltar racks, with the exception of the GRS 400C and 100C.
Dimensions: 48" x 11" x 11"

GHB-L
Large Hardware and Accessories Bag
Longer version of the GHB-M. Fits racks with curved and V-style bars.
Dimensions: 52" x 11" x 11"

Percussion Stands

The needs of the percussionist are just as great as a set drummer. Which is why Gibraltar designed a complete and innovative line of percussion stands and support hardware for percussionists.



9517
Double-braced
Double Conga Stand

Designed to fit most conga L-bracket mounting systems. Heavy-duty mounting assembly. Adjustable drum position guides. Memory position lock.



GCS-M / GCS-L
Single Conga Stands

Exclusive triangular shape allows for tighter drum setups. Accepts most makes and models of congas. Heavy-duty tubular legs with adjustable height.

Medium Stand fits 11" and 11 3/4" congas
Large Stand fits 11 3/4" and 12 1/2" congas



GCS-LSP
Single Conga Stand Low
For Seated Play

Lightweight, yet heavy duty. Sturdy, yet easy to tear down. Fits most brands of congas.



7716
Bongo Stand w/Adjustable
Clip Mount

Mount bongos via adjustable mounting clip on sturdy elliptical leg brace stand.



9516
Deluxe Bongo Stand
w/Inside Shell Mount

Mounts inside shell of bongo for solid support on heavy-duty double-braced stand.



GBSA
Bongo Seat Attachment

Can be attached to the bottom of throne base to hold bongos in playing position



GDS
Lightweight Djembe Stand

Lightweight. Length and height adjustments. Designed to fit various manufacturers' djembe drums. Breaks down easily for transport.



GPDS
Heavy Duty Pro Djembe Stand

The strongest djembe stand on the market. The best option for heavy hitters. Fully adjustable. Telescopic boom arm.



7614
Double-Braced Concert Cymbal Stand

Holds two hand-held concert cymbals (up to 22" diameter) for quick easy access.



GPRWS
Percussion Workstation on Gibraltar Rack

Stands 60" tall by 36" wide with 24"x24" table and percussion mounts.



7615
Percussion Table on Double-Braced Stand

24"x24" padded table with tripod stand.



SC-GRGSM
Rack Gong Stand Mount
Fits 1.5" diameter tubes. Comes with S hook for mounting standard rope mount gongs. (1pc)



SC-GGCSM
Gong Cymbal Stand Hook Mount



SC-RC
Rack Caster
Converts T-leg assembly into moveable system. 3" wheel with brake.

GPRGS-L
Large Gong Stand

Fits 28" to 40" Gongs. Made from 1-1/2" rack tubing. Collapses easily for transport. For easier transport on stage, use SC-RC rack casters.

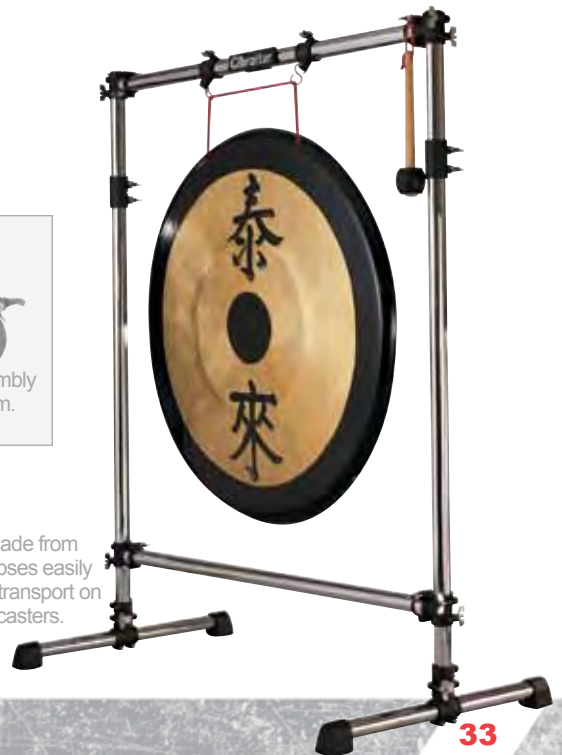

Accessories / Tuning



SC-SH
Stick Holder
3-1/2" diameter holder holds up to six pair of sticks. Detachable soft bag clamps to various drum stands. (1pk)



SC-SDH
Soft Drink Holder
Soft nylon holder clamps to any stand. Fits 1 liter bottles and most drink containers. (1pk)



SC-DSH
Deluxe Stick Holder
Deluxe black web stick holder with mount. (1pk)



SC-DSDH
Deluxe Soft Drink Holder
Deluxe black web soft drink holder with mount. (1pk)

SC-LPP
Leg Practice Pad with Strap
6" pad contoured fit with extra wide strap Velcro. Great for on-the-go practicing. (1pk)



SC-4244
Standard Drum Key
1/4" socket fits all standard drum key tension rods. (1pk)
SC-4244/6 (6pk)



SC-4245
High Torque Drum Key
Fits all standard tension rods. Larger shaft and handle section for more tension. (1pk)



SC-4248
Speed Key
Crank-shaped drum key to speed head changes. (1pk)



SC-GQRDK
Quick Release Drum Key
Gibraltar styled weighted drum key with quick release key ring. Hooks to any lanyard or carabineer clip-on for fast access. (1pk)



NEW
SC-GDCHTK
Drum Corps High Torque Drum Key
With comfortable ergonomic twist rubber-coated handle. (1pk)



SC-GDKH
T-Drum Key with Stand Clip Holder
High torque drum key fits all standard tension rods. Longer shaft and handle section for more tension. Clip holder fits standard cymbal stand for easy access. (1pk)



SC-GTK
Magnetized Tri Key Tool
Three tools in one. Drum key, Hex Key, and Phillips Head screw driver. (1pk)



SC-GWK
Wing Key
All in one adjustment tool
Has standard drum key socket, 1/2" socket for congas, bongos, timbales, tightens all sizes wing nuts and rack T handles. (1pk)



SC-DB
Drill Bit Drum Key
Fits most electric screwdrivers and drills. Makes changing drum heads a breeze. (1pk)



SC-RK
Ratchet Drum Key
Medium-weight ratchet style drum key. (1pk)



SC-RLW
Ratchet Lug Wrench
Heavy ratchet style drum tuning lug wrench. (1pk)



NEW
SC-GROBOKEY
Robo Key Speed Tuning Key
Fastest head changing tool around! Robo Key quadruples wrist turning speed to zip out those long tension rods. It increases every turn of your wrist into FOUR or more spins of the tension rod. (1pk)



SC-4235
External Tone Control
Hoop-mount tone control device attaches to virtually any tom tom or snare drum. (1pk)



SC-4400
Internal Tone Control
Mounts inside drum with adjustment on exterior. Exerts pressure by felt pad against the head. (1pk)



SC-TD
Tuning Dots
Lightweight foam rubber pieces with a light adhesive can be placed onto any drum head to mute overtones. (6pk)

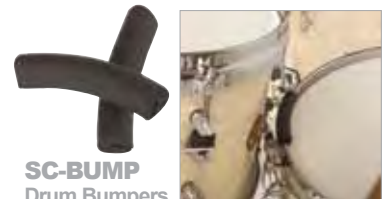

SC-BUMP
Drum Bumpers
Guards fit onto the rim of drums to stop bumps and dings. (2pk)



SC-DTK
Gibraltar Drummer's Tech Kit
Includes; bass drum click pad, tension rods, cymbal washers, sleeves, felts, snare cord and drum key. (1pk)

Drum Hoops / Suspension

STEEL POWER HOOPS

2.3mm heavy-duty chrome drum hoops.
Provide consistent shape / tension and clearer sound.



TOM HOOPS

SC-0804TT
8" / 4-Lug Tom

SC-0805TT
8" / 5-Lug Tom

SC-1005TT
10" / 5-Lug Tom

SC-1006TT
10" / 6-Lug Tom

SC-1205TT
12" / 5-Lug Tom

SC-1206TT
12" / 6-Lug Tom

SC-1208TT
12" / 8-Lug Tom

SC-1306TT
13" / 6-Lug Tom

SC-1406TT
14" / 6-Lug Tom

SC-1508TT
15" / 8-Lug Tom

SC-1608TT
16" / 8-Lug Tom

SC-1808TT
18" / 8-Lug Tom

SNARE BATTER SIDE HOOPS

SC-1308BS
13" / 8-Lug Batter Side

SC-1408BS
14" / 8-Lug Batter Side

SC-1410BS
14" / 10-Lug Batter Side

SNARE SIDE HOOPS

SC-1006SS
10" / 6-Lug Snare Side

SC-1206SS
12" / 6-Lug Snare Side

SC-1208SS
12" / 8-Lug Snare Side

SC-1308SS
13" / 8-Lug Snare Side

SC-1408SS
14" / 8-Lug Snare Side

SC-1410SS
14" / 10-Lug Snare Side

DIE CAST HOOPS

Custom Designed batter and snare side die-cast hoops feature reinforced tension points, large snare gates, and highly polished chrome finish. Slightly oversized, Gibraltar hoops allow drums to project without choking or restricting the head in any way.



SNARE BATTER SIDE HOOPS

SC-1308BSD
13" / 8-Lug Batter Side

SC-1408BSD
14" / 8-Lug Batter Side

SC-1410BSD
14" / 10-Lug Batter Side

SNARE SIDE HOOPS

SC-1308SSD
13" / 8-Lug Snare Side

SC-1408SSD
14" / 8-Lug Snare Side

SC-1410SSD
14" / 10-Lug Snare Side

WOOD HOOPS

NEW

Contoured Design

Maple wood hoops give a vintage appeal while adding a fat round sound with a powerful explosive edge.



SNARE BATTER SIDE HOOPS

SC-1408WTT
14" / 8-Lug Batter Side

SC-1410WTT
14" / 10-Lug Batter Side

SNARE SIDE HOOPS

SC-1408WSS
14" / 8-Lug Snare Side

SC-1410WSS
14" / 10-Lug Snare Side

DUNNETT R-CLASS

Contoured Design

Get the sound of wood hoops and the durability of a metal hoop in this hybrid wood / metal hoop from Dunnett.



SNARE BATTER SIDE METAL / WOOD HOOPS

SC-1408MW
14" / 8-Lug Batter Side

SC-1410MW
14" / 10-Lug Batter Side

GIBRALTAR TOM SUSPENSION SYSTEMS

The GTS is a proven mounting system for tom toms from 8" to 16" diameter that improves sound and can also be used to mount snare drums.

SC-GTS8/4
8" / 4-Lug

SC-GTS8/5
8" / 5-Lug

SC-GTS10/5
10" / 5-Lug

SC-GTS10/6
10" / 6-Lug

SC-GTS12/5
12" / 5-Lug

SC-GTS12/6
12" / 6-Lug

SC-GTS13/6
13" / 6-Lug

SC-GTS14/6
14" / 6-Lug

SC-GTS14/8
14" / 8-Lug

SC-GTS16/6
16" / 6-Lug

SC-GTS16/8
16" / 8-Lug

Note: GTS is not available for 15" diameter drums



NEW

Smaller mounting plate



SC-USS

Low mass suspension system fits 8", 10", 12", 13", and 14" tom sizes. Moveable tension rod mounts with drum key locks has rubber guard to protect drum.



NEW

Smaller mounting plate

Snare Drum / Tom Parts

TENSION RODS AND WASHERS

Tension Rod Reference Guide:

Key Rod – Tension rod with drum key style head. Generally used on snare drums, tom toms, and on the bottom of a bass drum.

T-Rod – Tension rod with T-handle. Used on bass drums.

Diameters

7/32" – Fits toms and snares for Pearl, CB, Mapex, Tama, Ludwig, Gretsch, Premier, Pacific, and most other manufacturers with the exception of Sonor. Fits DW drums prior to 1996 production.

6mm – Fits bass drums for Pearl, CB, Mapex, Tama, Ludwig, Gretsch, Yamaha, and other generic Taiwan-made drums. Other manufacturers generally use 7/32" bass drum key rods.

Lengths

SC-4J – 1-3/8" (35mm) – Fits many piccolo snare drums and small tom toms.

SC-4C – 1-5/8" (41mm) – Fits many snare drums, small and medium toms, and some floor toms.

SC-4B – 2" (52mm) – Fits toms and floor toms with a lot of space between hoop and tension casing.

SC-4E – 2-3/8" (58mm) – Fits some floor toms and bass drums.

SC-4J 1-3/8" (35mm) Tension Rods w/washer

Fits many piccolo snare drums and small toms. (6pk)

SC-4C 1-5/8" (41mm) Tension Rods w/washer

Fits many snare drums, small and medium toms, and some floor toms. (6pk)

SC-4B 2" (52MM) Tension Rods w/washer

Fits toms and floor toms with a lot of space between hoop and tension casing. (6pk)

SC-4E 2-3/8" (58mm) Tension Rods w/washer

Fits some floor toms and bass drums. (6pk)

SC-LN Small Swivel Nuts 7/32"

Small swivel nuts fit most tom and snare tension rods. (12pk)

SC-LG Large swivel Nuts 6MM

Large swivel nuts fit most bass drum tension rods. (12pk)

SC-ILS Internal Lug Screws

Replacement screws for snare, tom, and bass drum lugs. 10pk screws with washers.

SC-11 Metal Tension Rod washers

(12pk)

SC-12 Nylon Tension Rod washers

(12pk)

SC-SSW ABS Tension Rod washers

(10pk)

SNARE PARTS



SC-GDR40

Dunnett R40 Swivel Lever Quick Release Throw-off
Gibraltar's Dunnett R-Class throw-off is the replacement to the popular SC-DSLTO R-Class throw and incorporates more refinements and functionality.

- The famous 360° swivel adjustable lever
- Includes Quick Release snare and butt side mechanism
- R40 is smaller and substantially lighter
- The first throw-off featuring adjustable tension knob friction to prevent backing off
- Sliding track-mounting system makes it a perfect fit for any drum shell regardless of thickness
- 1 1/2" hole spacing
- Butt End 1" mount hole spacing



SC-DLSTO Deluxe Classic Snare Throw-off

Cast metal classic styled strainer with mounting hardware. Mount hole spacing 2-3/4". (1pk)



SC-DSTO Deluxe Modern Throw-off

Side throw modern style snare strainer comes with mounting hardware. Mount hole spacing 5/8". (1pk)



SC-STO Deluxe Throw-off

Quick-release throw-off mechanism allows easy adjustment of snare tension. Mount hole spacing 1-1/2". (1pk)

SC-DPTO Deluxe Classic Piccolo Throw-off

Cast piccolo metal classic styled strainer with mounting hardware. Mount hole spacing 5/8". (1pk)

SC-PTO Piccolo Throw-off

Throw-off for short drums. Mount hole spacing 7/8". (1pk)



Snare Drum Parts

SC-SSBE

Standard Snare Butt End
2-3/4" mount hole spacing. (1pk)



SC-SBE

Deluxe Snare Butt End
Butt-end assembly with deep channel and high tension drum key bolts eliminates snare slippage 1-3/4" mount hole spacing. (1pk)



SC-DSLBE

Dunnett matching Snare Butt End
All metal, die-cast butt end 1" mount hole spacing. (1pk)



SC-NSC

Nylon Snare Strip (4pk)



SC-SSC

Metal Snare Cord
High test metal braided cord (4pk)

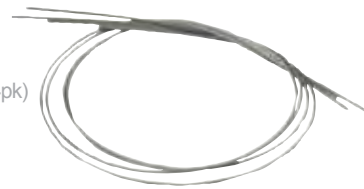

SC-SC

Nylon Snare Cord
Tight weave nylon cord with double laminated ends. (6pk)



Aquiels Priester - Hangar, Freakeys

SNARE WIRES

Snare Wire Reference Guide:

Inches – This designates the diameter drum the snare is designed to fit. It may not be the actual length of the snare wire assembly.

Strands – This is the amount of snare wires on each snare.

Normal Fit – Most snares do not fit past the edge of the snare side drum head. (This includes all Gibraltar snares except SC-4467L and SC363E.)

Extended Length – Some snare drums utilize snare wires that fit over the edge of the side hoop. The SC-4467L will fit most drums with this feature.

Special Snares – The SC-363E fits Ludwig Super Sensitive snare drums with non-individually adjustable snare wire systems and a Yamaha model which utilizes split snares.

Note - Gibraltar snares are designed to fit many manufacturers' snare drums. They are made to fit snare drums ranging from 10" to 14" in diameter and are primarily designed for Jazz, Rock, and concert performance applications, such as field marching corps or similar performance situations.

SC-016A
10" 16-Strand



SC-216A
12" 16-Strand



SC-1316
13" 16-Strand

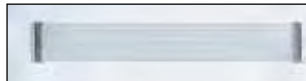

SC-360A
13" 12-Strand



SC-1320S
13" 20-Strand
With stainless plates and chrome wire.



SC-363E
14" 20-Strand
SS Style
(Split 10/10)



SC-4459
14" 16-Strand



SC-4467
14" 20-Strand



SC-4471
14" 42-Strand



SC-1420S
14" 20-Strand
With stainless plates and chrome wire.



SC-4467L
16" 20-Strand
Extended Length
Fits 14" FFS
Style Snare Drum



Bass Drum Parts

WOOD BASS DRUM HOOPS

8-ply all-maple construction finished in natural and black lacquer gloss finish.

BLACK	MAPLE
SC-18BK 18" Hoop	SC-18M 18" Hoop
SC-20BK 20" Hoop	SC-20M 20" Hoop
SC-22BK 22" Hoop	SC-22M 22" Hoop
SC-24BK 24" Hoop	SC-24M 24" Hoop



Bass Drum Tension Rod Reference Guide:

6mm – Fits Pearl (prior to 1995), CB, Mapex, and many generic Taiwan-made drums.

7/32" – Fits most other manufacturers' drums with the exception of Sonor and DW. Fits Pearl bass drums made after 1995. Fits DW bass drums prior to 1996 production.

Bass Drum Tension Rod Lengths – All Gibraltar bass drum T-rods and key rods are 4-3/4" (108mm) long. They fit most manufacturers' bass drums as previously noted, with the exception of drums, that have extended space between the hoop and lug receptacle. We recommend that you measure this space before purchasing.

BASS DRUM PARTS AND ACCESSORIES

SC-GCP

Bass Drum Click Pad
Mylar pad with metal disk gives punch to bass drum mounts to head with adhesive. (1pk)



SC-GDCP

Double Bass Drum Click Pad
Mylar pad with metal disk gives punch to bass drum mounts to head with adhesive. (1pk)



SC-BPL

Bass Drum Beater Pad Vinyl
Leather-like vinyl pad mounts to drum head. (4pk)



SC-DPP

Double Bass Drum Beater Pad
Uses same material as SC-BPL for use with double pedals. (1pk)



SC-BF

Bass Drum Felt Strips
A 2 1/4" wide strip mounts inside drum head. Fits up to 26" drum. (2pk)



SC-BDHG

Bass Drum Hoop Guard
Protect lacquer bass drum hoops from drum pedal hoop clamp. (2pk)



SC-BDHI

Bass Drum Hoop Rubber Insert
Fits into metal bass drum hoop under drum pedal hoop clamp. (1pk)



SC-BDKR/S

Bass Drum Key Rod 7/32
4-3/8" (106mm) long x 7/32 diameter. 7/32 thread Key style. (4pk)



SC-BDKR/L

Bass Drum Key Rod 6mm
4-3/8" (112mm) long x 6mm diameter. 6mm thread Key style. (4pk)



SC-BDTR/S

Bass Drum T-Rod 7/32"
4-3/8" (112mm) long x 7/32 diameter. 7/32" T-style. (4pk)



SC-BDTR/L

Bass Drum T-Rod 6mm"
4-3/8" (112mm) long x 6mm diameter. 6mm" T-style. (4pk)



SC-CH

Bass Drum Claw Hook
(4pk)



SC-BDPM

Bass Drum Platform fits 18/20"
Raises small bass drums 2" off the ground. Fits 18" and 20" bass drums. (1pk)



SC-BS2

Light Weight Bass Drum Spurs
Solid steel rod with rubber tip and cast mounts. Comes with screws. (pair)
12" spur length
3 hole mount 1.5" x 2"



SC-BS5

Medium Weight Bass Drum Spurs
Strong yet lightweight spur set. Maximum support without overkill. (pair)
12" spur length
2 hole mount, 2" spacing



SC-BS4

Pro Bass drum Spurs with bracket
Telescopic bass drum spurs with angle-adjustable mount. (pair)
Spur length up to 14"
4 hole mount, 1.5" x 1.75" x 2.5"



SC-4402

Bass Drum Anchor
Attaches to the bottom of front counter hoop to prevent bass drum slippage. Dual reversible tips. (1pk)

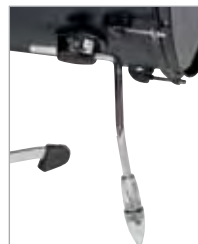

SC-GWS

Dunnett R-Class Gull Wing Spurs
Turn your floor tom into bass drum. 12.5mm gull wing spurs fit into floor tom leg mount. Use Gibraltar's SC-BDPM pedal mount (1pk)

Pedal Parts / Beaters

BASS DRUM PEDAL PARTS

SC-15C
Generic Bass Drum
Pedal Spring (2pk)



SC-15F
Universal Bass Drum
Pedal Spring (2pk)



SC-0052
Bass Drum Pedal Spring
with triangle rod (2pk)



SC-0053
Bass Drum Pedal Spring
tension assembly (2pk)



SC-0055
Bass Drum Hoop Clamp
Tension Screw (2pk)



SC-0121
8mm Key Screw Beater Hub
(4pk)



SC-0129
6mm Key Screw for U-Joint
(4pk)



SC-15B
Kevlar Bass Drum
Pedal Strap (1pk)
11/16" W x 7 5/8" L



SC-TS
Gibraltar Pedal Board Toe Stop
Fits all Gibraltar and many other
manufacturers' pedal boards. (2pk)



SC-GLO
Gibraltar Lube
Perfect for use on hi-hat and bass
drum pedals to protect bearings
and eliminate squeaks. (1pk)



BEATERS

SC-3259
Felt Beater Long Shaft / Black

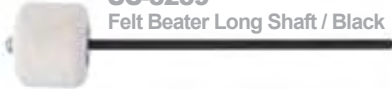

SC-3262
Wood Bass Drum Beater

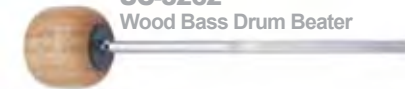

SC-DSAB
Dual Surface Self-Aligning Beater



SC-3260
Felt Beater Standard Shaft / Black



SC-3263
Wood Beater Standard Shaft / Black

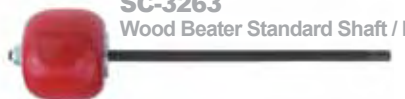

SC-RFSAB
Round Flat Self-Aligning Beater



SC-3261
Felt Bass Drum Beater

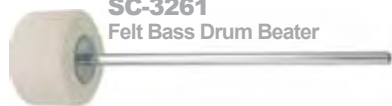

SC-3264
Wood Beater Long Shaft / Black

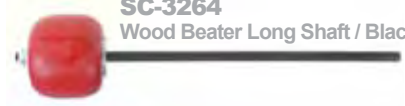

SC-LBDB
Light Weight Bass Drum Beater



Tom Mounting

Reference Guide:

L-Rod Tom Arm Mounts

It is always recommended that you check your drum for actual Tom Arm size before purchasing.

12.7mm Arms – Fit most DW, Gretsch, and Gibraltar SC-STL2 and SC-STL3 tom brackets.

Available 12.7mm L-Rod Arms: SC-BALRL, SC-BCLR, SC-DWLR, SC-LBL, SC-LBL-1, SC-LGUA, SC-LGUA-PVT and SC-SLLRM.

10.5mm Arms - Fit most Tama, Ludwig, Premier, Pacific, Taye, Ayotte, Roland Electronic pads, current Remo drums.

Available 10.5mm L-Rod Arms: SC-BALRM, SC-LBM-1, SC-LRM-1, SC-MEDUA, SC-MEDUA-PVT, SC-SLRM, and SC-SLR.

9.5mm Arms - Fit older Ludwig drums, Gibraltar SC-STL2, SC-STL3, SC-STL4, and tom brackets along with percussion items such as cowbells, synthetic blocks and mountable tambourines.

Available 9.5mm L-Rod Arms: SC-LBS, SC-LRS-1.

Tom Arm Mounting Systems

7/8" Diameter Tom Arm Mounts - Fit most current Pearl, current CB, older Mapex sets, and other generic made drums.

Available 7/8" Arms: SC-700HA, SC-78UA, SC-BA78.

3/4" Diameter Tom Arm Mounts - Fit older Pearl, older Sonor, older CB, older Remo, and other Generic made drums.

Available 3/4" Arms: SC-600HA.

Hex Rod Tom Arm Mounts – Fit current Mapex, current Sonor, and older Remo.

Available Hex Rod Arms: SC-BALRH, SC-HBL, SC-HEXUA, SC-HEXUA-PV and SC-LRHS-1.

Tom Brackets

Gibraltar tom brackets are designed to fit primarily on Gibraltar GTS mounting systems (on mounting plate). If you plan to mount tom brackets directly on a drum shell, you may need longer screws, depending on the thickness of your shell.

Bass Drum Brackets / Receptacles

These are designed to be mounted on a bass drum shell and come with extended length mounting screws, washers and fasteners to accommodate most drum shell thicknesses.

Tom Arms

No other company offers as many options for mounting a drum as Gibraltar. We suggest you consider the following points before purchasing a Gibraltar Tom Arm:

- Size and weight of drum to be mounted.
- Positioning requirements (fixed or moveable).
- Attachment point of tom arm (from stand, drum rack, bass drum, or multi-clamp).
- Cost of all parts needed to complete mounting system (example: stand, multi-clamp, tom arm and bracket). Choose the most cost effective, physically-secure system.

L-RODS

Choose from several sizes to fit your specific setup. 9.5mm, 10.5mm, and 12.7mm, and Hex L-Rods work with SC-STL2 and SC-STL3 tom mounts and many manufacturers' mounts. (See chart for details).

SC-LRS-1

Small 9.5mm L-Rod
Tom/Cowbell attachment arms fit directly in multi clamp
12mm x 9.5mm dia 3-1/2"
knurled mount area (1pk)



SC-LRM-1

Medium 10.5mm L-Rod
12mm x 10.5mm dia 3-1/2"
knurled mounting area (1pk)

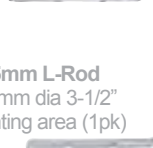

SC-LRL-1

Large 12.7mm L-Rod
12mm x 12.7mm dia 3-1/2"
knurled mounting area (1pk)



SC-LRHS-1

Hex L-Rod
12mm x Hex 3-1/2"
Hex mounting area (1pk)

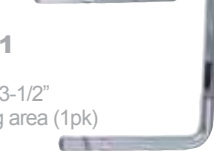

SUPER L-RODS

Fits directly into a multi clamp. Extra large diameter for strength and stability. Works with SC-STL2 and SC-STL3 mounts

SC-SLR

Super L-Rod 10.5mm
26.5mm x 10.5mm 6 inch
arm w/ 3-3/4" knurled
mounting area (1pk)

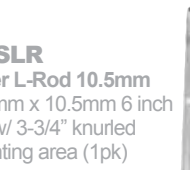

SC-DWLR

Super L-Rod 12.7mm
26.5mm x 12.7mm 6 inch
arm w/ 3-3/4" knurled
mounting area (1pk)



SC-DWLR Y

Yamaha Hex Style L-Rod
tom arm (1pk)



BALL L-RODS

These L-Rods fit various manufacturers' tom mounting systems. (see "Tom Mounting Systems Glossary") They can be mounted in any of the L-Rod platforms with post or with clamp and in many manufacturers' original tom mounting systems.

SC-LBS

Small 9.5mm Ball L-Rod
9.5mm 4" knurled mounting area (1pk)



SC-LBM

Medium 10.5mm Ball L-Rod
10.5mm 4" knurled mounting area (1pk)



SC-LBL

Large 12.7mm Ball L-Rod
12.7mm 4" knurled mounting area (1pk)



SC-HBL

Hex Ball L-Rod
Hex 5" mounting area (1pk)

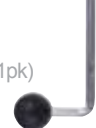

L-ROD BALL ARMS

L-Rod arms with ball adjustment for 360 degree positioning.

SC-BALRM

Medium 10.5mm L-Rod Ball Arm
10.5mm 5-1/4" knurled mounting area
with 6" 7/8" diameter down tube (1pk)



SC-BALRL

Large 12.7mm L-Rod Ball Arm
12.7mm 5-1/4" knurled mounting area
with 6" 7/8" diameter down tube (1pk)

SC-BALRH

Hex L-Rod Ball Arm
5-1/4" Hex mounting area with 6" 7/8"
diameter down tube (1pk)

Clam Style Ball L-Rod Tom Arms

SC-BCLR-M

Ball Clam Style L-Rod 10.5mm Tom Arm
10.5mm L-Rod with 8" 7/8" diameter
down tube (1pk)

SC-BCLR-L

Ball Clam Style L-Rod 12.7mm Tom Arm
12.7mm L-Rod with 8" 7/8" diameter
down tube (1pk)

SC-BCLR-H

Ball Clam Style L-Rod Hex Tom Arm
Hex L-Rod with 8" 7/8" diameter
down tube (1pk)

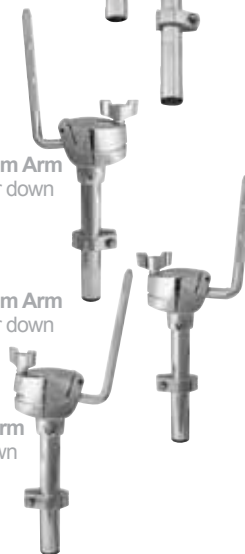

L-ROD BALL WITH MOUNT

SC-SLRM

Medium 10.5mm Single L-Rod mount with Clamp
Accepts 1/2" to 1" diameter tubes. Great for adding small tom or percussion accessory to cymbal stand. (1pk)

SC-SLLRM

Large 12.7mm Single L-Rod mount with Clamp
Accepts 1/2" to 1" dia tubes. Great for adding small tom to cymbal stand. (1pk)

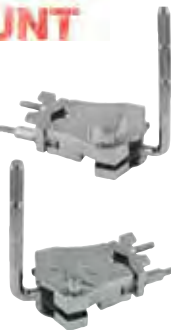

BALL L-ROD PLATFORM MOUNTS

Designed to be used with any L-Rod ball mount. Gibraltar's L-Rod platforms allow tom mounting via bass drums and all types of stands and rack systems.

SC-SPC

Single Ball L-Rod Platform with Clamp
Single L-Rod platform with adjustable multi clamp. (Multi-clamp fits up to 1" diameter post) (1pk)

SC-DPC

Double Ball L-Rod Platform with Clamp
Double L-Rod platform with adjustable multi clamp (Multi clamp fits up to 1" dia tube) (1pk)

SC-SPCM

Single Post L-Rod Mount
Single L-Rod platform with 1" diameter 17" vertical post (for single tom mounting) (1pk)

SC-SP

Single Ball L-Rod Platform with Post
Single L-Rod platform with 1" diameter 10" vertical post (for single tom mounting) (1pk)

SC-DP

Double Ball L-Rod Platform with Post
Double L-Rod platform with 1" diameter 17" vertical post (for double tom mounting) (1pk)

SC-BJEA

Ball Joint Extension Arm
Use with Cymbal arms and Accessory Arms fits into Ball L-Rod platforms and mounts. Accepts 3/4" and 7/8" diameter tubes approximately 5" in length (1pk)



TOM ARMS

Gibraltar's Ultra Adjust Gearless positioning system gives limitless adjustment.

SC-MEDUA

Medium 10.5mm L-Rod Ultra Adjust Tom Arm
10.5mm diameter 5" L-Rod with Ultra adjustment positioning and 7/8" diameter down tube (1pk)

SC-LGUA

Large 12.7mm L-Rod Ultra Adjust Tom Arm
12.7mm diameter 5" L-Rod on Ultra adjustment positioning and 7/8" dia 10" down tube (1pk)

SC-HEXUA

Hex L-Rod Ultra Adjust Tom Arm
5" Hex L-Rod with Ultra adjustment positioning and 7/8" dia. 10" down tube (1pk)

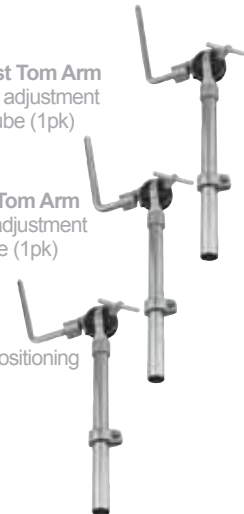

Pearl style tom arms featuring ratchet, ball style, and Ultra Adjust positioning.

SC-600HA

3/4" Diameter Ratchet Style Tom Arm
Ratchet style arm in 3/4" diameter with 10" down tube. Fits many older and non-branded drum sets (1pk)

SC-700HA

7/8" Diameter Ratchet Style Tom Arm
Pearl style ratchet arm in 7/8" diameter with 10" down tube (1pk)

SC-78UA

7/8" Diameter Ultra Adjust Tom Arm
Ultra Adjustment with 7/8" diameter arm with 10" down tube (1pk)

SC-BA78

7/8" Diameter Ball Arm Tom Arm
Ultra Adjustment with 7/8" diameter arm with 10" down tube (1pk)



MEMORY LOCKS

SC-ML1

1" Diameter Memory Lock (4pk)

SC-ML34

3/4" Diameter Memory Lock (4pk)

SC-ML78

7/8" Diameter Memory Lock (4pk)



HINGED MEMORY LOCKS

SC-HML127

Hinged Memory Lock 12.7mm (1pk)

SC-HML1

Hinged Memory Lock 1" (1pk)

SC-HML34

Hinged Memory Lock 3/4" (1pk)

SC-HML78

Hinged Memory Lock 7/8" (1pk)

SC-HML105

Hinged Memory Lock 10.5mm (1pk)



Tom Mounting Systems

RAIL MOUNT

SC-GVRM

Rail Mount Consolette with Mounting Hardware
Height and rail position adjustments fit 10.5mm w/ memory lock. Fits most 2-hole drill patterns and includes protection bag for transport (1pk)

SC-RM

Dunnett R-Class Rail Mount
12.5mm rail mount fits into floor tom mount for adding tom. Create your own club kit (1pk)



BASS DRUM MOUNTS

SC-670BB

Double Tom, Bass Drum Bracket
Mounts on bass drum and accepts 7/8" dia tubes. Works with Gib tom mounting posts and other manufacturers' 1" dia mount posts. (1pk)



SC-1BDB

Single Tom Bass Drum Bracket
Mounts on bass drum and accepts 7/8" dia tubes. Works with Gib tom mounting posts and other manufacturers' 1" diameter mount posts. (1pk)



TOM / FLOOR TOM MOUNTING BRACKETS

SC-670TB

Tom Mounting Bracket Pearl style 7/8" diameter
Fits Pearl 7/8" Pearl Arm. Works with Gib. SC-700HA, SC-78UA, SC-BA78 (1pk)



SC-STL2

Super L-Rod Tom / Floor Tom Mount key adjust
Works with all L-Rods. Uses SC-LDML memory lock. Hole Spacing 2" on center (1pk)



SC-STL3

Super L-Rod Tom / Floor Tom Mount wing adjust
Works with all L-Rods. Uses SC-LDML memory lock. Hole Spacing 2" on center (1pk)



SC-STL4

L-Rod Tom / Floor Tom Mount Chrome
Fits 9.5mm to 12.7mm L-rods or floor tom legs. Hole Spacing 2" on center (1pk)



SC-LDML

L-Rod Memory Lock
Memory lock for super tom mount STL2 STL3 (1pk)



FLOOR TOM LEGS AND ACCESSORIES

SC-TL1A

Floor Tom Legs 9.5mm
21" Length (3pk)

SC-TL2A

Floor Tom Legs 10.5mm
21" Length (3pk)

SC-TL3A

Floor Tom Legs 12.7mm
21" Length (3pk)

SC-RTS

Floor Tom Small Rubber Feet (3pk)

SC-RTL

Floor Tom Large Rubber Feet (3pk)

SC-FFT

Floating Floor Tom Rubber Feet 10.5mm
Fits 10.5mm floor tom legs. A hollow tip allows each foot to float promoting increased vibration and resonance (3pk)

SC-TL2

Tom / Floor Tom Leg Bracket
Accepts 9.5mm to 10.5mm rods. 2" mount hole spacing (1pk)



PLATFORM ARM MOUNTS

Perfect match for combining tom arms and cymbal arms together. 3-hole platforms with and without adjustments will get you into position.

SC-PM

3-Hole Platform with 1" Diameter 16" Post
Great for mounting tom arms and or cymbal arms. Mounts two or more items from racks or stands (1pk)

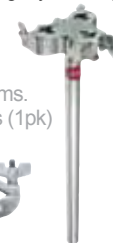

SC-4429

3-Hole Platform Mount
Three-way clamp accepts 1/2" through 1" dia. tubes (1pk)



SC-APM

3-Hole Adjustable Platform with Post
Three-way clamps accept 1/2" through 1" dia. tubes. Two sides are adjustable for detailed positioning (1pk)



SC-EA100

Extension Arm with Adjustable Grabber Clamp
Universal extension arm with 360 degree ratchet plus a multi-clamp attachment. Allows infinite positioning for almost any piece of drum hardware (1pk)
1" dia. 12-3/4" down tube

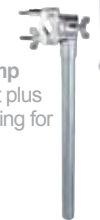

SC-EA200

Super Grabber Adjustable Length Extension Arm
360 degree ratchet super grabber clamp fits up to 1" diameter tubes with length adjustment (1pk)
Extends 13" to 25"



SC-EA300

Ultra Adjust "Flex" Extension Arm with Super Grabber Clamps and Length Adjustment
Extension arm with universal grabber clamps, length adjustment, and "flex" Ultra Adjust positioning (1pk)

Cymbal Arms / Mounting

CYMBAL ARMS AND MOUNTING SYSTEMS



SC-LBBT
SC-SBBT
Boom Section



SC-LBBT
SC-SBBT
Hideaway
Boom



SC-3325B-1
Cymbal Boom Arm with Ratchet Tilter
3/4" diameter, 13.8" down tube length
with 16" boom rod (1pk)



SC-3325B-1
Boom Section



SC-3325B-1
Ratchet Tilter

SC-LBBT

Long Cymbal Boom Brake Tilter
7/8" dia. tube 16" down tube length
18", 12.7mm boom rod with hinged
memory lock (1pk)

SC-SBBT

Short Cymbal Boom Brake Tilter
7/8" dia. tube 10" down tube length 12", 12.7mm
boom rod with hinged memory lock (1pk)

NEW

**AWARD
WINNING**

SC-LBBT-TP
Turning Point

Long Cymbal Boom Brake Tilter
7/8" dia. tube 16" down tube length
18", 12.7mm boom rod with hinged
memory lock (1pk)

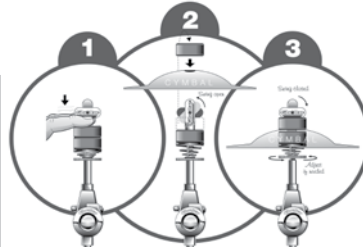

SC-LBBT-TP
SC-SBBT-TP
Swing Nut
Auto Cymbal Tilter



SC-SBBT-TP
Turning Point

Short Cymbal Boom Brake Tilter
7/8" dia. tube 10" down tube length 12", 12.7mm
boom rod with hinged memory lock (1pk)



SC-4425B-1
SC-4425MB
Ratchet Tilter



SC-4425B-1
SC-4425MB
Boom Section

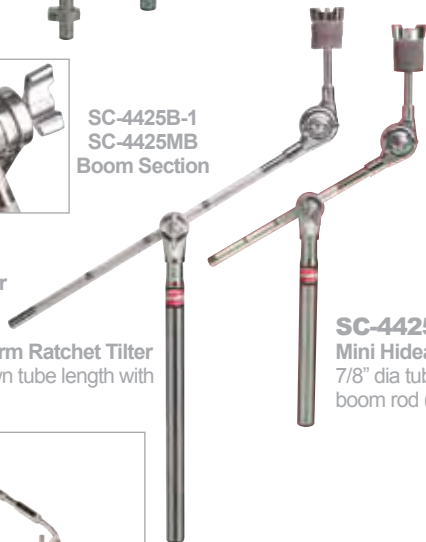

SC-4425B-1

Cymbal Hideaway Boom Arm Ratchet Tilter
7/8" diameter tube, 13.8" down tube length with
16" boom rod (1pk)



SC-4425B-1
SC-4425MB
Hideaway
Boom

SC-4425MB

Mini Hideaway Cymbal Boom Ratchet Tilter
7/8" dia tube, 10" down tube length with 12"
boom rod (1pk)



SC-UCB

Ultra Adjust Cymbal Extension Arm
Great for china or crash cymbal positioning
in tight spaces with maximum visual effect
Extends from 27" to 35.5" (1pk)



SC-GGCSM
Gong Cymbal
Stand Hook
Mount



SC-BJEA

Ball Joint Extension Arm
Use with cymbal arms and accessory
arms. Fits into ball L-Rod platforms and
mount. Accepts 3/4" and 7/8" diameter
tubes (1pk)



SC-USCB

Ultra Adjust Single Cymbal Boom Arm
with 360° adjustment and hideaway boom
section. 20.5" down tube length with 11-3/4"
boom rod (1pk)

Cymbal Arms / Attachments

CYMBAL ARMS AND ATTACHMENTS



SC-SBRA-TP

Turning Point

Short Boom Rod Arm w/ Brake-Tilter

12", 12.7mm boom rod with hinged memory lock (1pk)

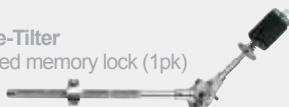

SC-LBRA-TP

Turning Point

Long Boom Rod Arm w/ Brake-Tilter

18", 12.7mm boom rod with hinged memory lock (1pk)



SC-GCA-TP

Turning Point

Grabber Cymbal Arm w/ Brake-Tilter

18" arm section 12.7mm dia. with standard grabber clamp (1pk)

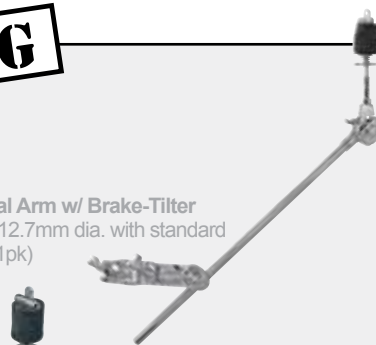

SC-DCT-TP

Turning Point

Deluxe Cymbal Brake-Tilter Attachment w/ swivel adjustment

Fits onto most cymbal boom stand rods. Lets you add on additional cymbal to existing cymbal stand. (1pk)



SC-SBRA-BT

Short Boom Rod Arm w/ Brake-Tilter

12", 12.7mm boom rod with hinged memory lock (1pk)



SC-LBRA-BT

Long Boom Rod Arm w/ Brake-Tilter

18", 12.7mm boom rod with hinged memory lock (1pk)

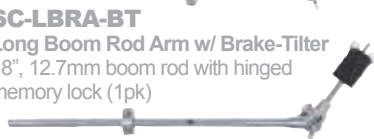

SC-GCA-BT

Grabber Cymbal Arm w/ Brake-Tilter

18" arm section 12.7mm dia. with standard grabber clamp (1pk)



SC-GCA

Grabber Cymbal Arm

18" arm section 12.7mm dia. with standard grabber clamp (1pk)



SC-CMBAC

Medium Cymbal Boom Attachment Clamp

12" boom, standard tilter. Clamps to stand tube. (1pk)



SC-CLBAC

Long Cymbal Boom Attachment Clamp

18" boom, standard tilter. Clamps to stand tube. (1pk)



SC-CMBRA

Medium Cymbal Boom Ratchet Assembly

12" boom, standard tilter. Fits 9.5mm to 12.7mm boom Rods (1pk)



SC-CLBRA

Long Cymbal Boom Ratchet Assembly

18" boom, standard tilter. Fits 9.5mm to 12.7mm boom Rods (1pk)



SC-DCT-BT

Deluxe Cymbal Brake-Tilter Attachment w/ swivel adjustment

Fits onto most cymbal boom stand rods. Lets you add on additional cymbal to existing cymbal stand. (1pk)



SC-CPM

Cymbal Post Mount

Fits onto percussion post mount 12" cymbal post section (1pk)



SC-GBDCA

Gibraltar Bass Drum Mounted Cymbal Arm

12" cymbal post section (1pk)



SC-ECLAC

Extended Cymbal L-Rod Accessory Clamp

10" cymbal rod section (1pk)



SC-CAM

Gib Cymbal Arm Mount

8" length with 4-inch vertical (1pk)



SC-CLAC

Cymbal L-Arm Adjustable Clamp

8" length with 4-inch vertical section (1pk)



SC-CLRA

Cymbal L-Arm Ratchet Assembly

Fits onto 9.5mm to 12.7mm rods (1pk)



Cymbal Stackers / Clamps

CYMBAL STACKERS

SC-MCSA4

4" Mini Cymbal Stacker

Add second cymbal. Screws onto existing 8mm cymbal tilter (1pk)



SC-MCSA6

6" Mini Cymbal Stacker

Add second cymbal. Screws onto existing 8mm cymbal tilter (1pk)



SC-CSA

Straight Cymbal Stacker Assembly with Tilter

Allows two cymbals (of any size) to be placed on top of each other with approx 8" of clearance between them. Mounts on most 6mm and 8mm cymbal stand tops (1pk)



SC-BCSA

Boom Cymbal Stacker Assembly with Tilter

Allows two cymbals (of any size) to be placed on top of each other with boom angle between them. Mounts on most 6mm and 8mm cymbal stand tops (1pk)



MULTI CLAMPS

SC-BGC

Basic Grabber Clamp 2-Hole

Economic version of the SC-4425G without hinged clamps (1pk)



SC-4425G

Standard Grabber 2-Hole

Double clamp assembly accepts 1/2" though 1" diameter (1pk)



SC-PUGC

Adjustable Angle Multi-Clamp 2-Hole

Pearl-type grabber clamp with angled center post with rotating clamp at each end (1pk)



SC-UGC

Universal Adjustable Grabber Clamp 2-Hole

Double clamp accepts 5/8" through 1-1/4" diameter arms (1pk)



SC-SUGC

Super Universal Grabber Clamp 2-Hole

Features double multi-clamps, accepts 5/8" through 1-1/2" dia. arms and rack tubes. Gripping surface is 2-1/2 times larger for added strength (1pk)



SC-4429

3-Hole Platform Mount

Three-way clamp accepts 1/2" through 1" diameter tubes (1pk)



Cymbal mounting reference guide

Use the listing below to find the best cymbal mounting arm for the type of cymbal you're mounting

MODEL	SPLASH	CRASH	EFFECTS	RIDE
SC-3325B-1	•	•	•	•
SC-4425B-1	•	•	•	•
SC-4425MB	•	•	•	•
SC-SB	•	•	•	•
SC-LB	•	•	•	•
SC-SBBT	•	•	•	•
SC-LBBT	•	•	•	•
SC-UCB	•	•	•	•
SC-USCB	•	•	•	•
SC-GCA	•	•	•	•
SC-GBDCA	•	•	•	•
SC-CT	•	•	•	•
SC-DCT	•	•	•	•
SC-ECLAC	•	•	•	•
SC-CPM	•	•	•	•
SC-CAM	•	•	•	•
SC-CLAC	•	•	•	•
SC-CLRA	•	•	•	•
SC-CMBAC	•	•	•	•
SC-CLBRA	•	•	•	•
SC-CLBAC	•	•	•	•
SC-CMBRA	•	•	•	•

Cymbal Stand Parts

CYMBAL STAND PARTS

SC-CS6MM

6mm Cymbal Sleeves

Sleeves fit over threaded portion of cymbal mount to protect cymbals (4pk)



SC-MCW

Metal Cymbal Stand Cup Washer

Used on cymbal tilters. Fits 8mm (4pk)



SC-TCWN6

6mm Tama Style Wing Nut

6mm Tama Style Wing Nut
ABS wing screw and cymbal shaft protector all in one (6mm) (4pk)



SC-CS8MM

8mm Cymbal Sleeve

Sleeves fit over threaded portion of cymbal mount to protect cymbals (4pk)



SC-CFS/4

Cymbal Felt Short

Small 3/4" thick cymbal felts (4pk)



SC-TCWN

8MM Tama Style Wing Nut

8MM Tama Style Wing Nut
ABS wing screw and cymbal shaft protector all in one (6mm) (4pk)



SC-19A

Flanged Base Tall Cymbal Sleeve 8mm

Flanged base (8mm) for Gibraltar 9600 cymbal tilters, extended length (4pk)



SC-CFL/4

Cymbal Felt Tall

Large 1-1/2" thick cymbal felts (4pk)



SC-PC07

Large Rubber Feet (3pk)



SC-19B

Flanged Base Short Cymbal Sleeve 8mm

Flanged base (8mm) for Gibraltar 9600 cymbal tilters, shorter shaft length (4pk)



SC-13G

6mm Light Duty Wing Nut (5pk)



SC-PC08

Elliptical Leg Rubber Feet (3pk)



SC-20A

Rubber Cymbal Seat / Sleeve Tall

Rubber flanged base with 8mm nylon sleeve enhances and protects cymbals. Extended height (1pk)



SC-13E

8mm Light Duty Wing Nut (5pk)



SC-PC09

Large Round Gibraltar Rubber Feet (3pk)



SC-20B

Rubber Cymbal Seat / Sleeve Short

Rubber flanged base with 8mm nylon sleeve enhances and protects cymbals. Short height (1pk)



SC-13P2

8mm Heavy Duty Wing Nut (2pk)



SC-PC10

Small Round Gibraltar Rubber Feet (3pk)



SC-13P3

6mm Wing Screw (2pk)



SC-0008

Gib 6mm Wing Screw (2pk)



SC-PC13

Small Rubber Feet (3pk)



cross reference chart

Model	Item Description	CB	DW	GMS	Gretsch	Ludwig	Mapex	Pacific	Pearl	Premier	Remo	Sonor	Tama	Tayye	Yamaha	Generic
SC-CS6MM	6mm Cymbal Sleeves	•														
SC-CS8MM	8mm Cymbal Sleeve		•	•	NA	•	•	•	•	•	•	•	•	•	•	•
SC-19A	Flanged Base Tall Cymbal Sleeve	•														
SC-19B	Flanged Base Short Cymbal Sleeve	•		•		•	•	•		•	•					
SC-20A	Rubber Cymbal Sleeve Tall		•						•				•		•	•
SC-20B	Rubber Cymbal Sleeve Short	•		•		•	•	•		•	•			•		
SC-CFS/4	Cymbal Felt Short	•	•	•	•	•	•	•	•	•	•	•	•	•	•	•
SC-CFL/4	Cymbal Felt Tall	•	•	•	•	•	•	•	•	•	•	•	•	•	•	•
SC-13G	6mm Light Duty Wing Nut	•														
SC-13E	8mm Light Duty Wing Nut					•	•	•	•	•	•	•	•	•	•	•
SC-13P3	6mm Heavy-Duty Wing Nut	•						•					•	•	•	•
SC-13P2	8mm Heavy-Duty Wing Nut		•	•	•	•	•	•	•	•	•	•	•	•	•	•
SC-MCW	Metal Cymbal Stand Cup Washer	•	•	•	•	•	•	•	•	•	•	•	•	•	•	•
SC-PC13	Small Rubber Feet	•		NA		•	•	•	•	•	•	•	•	•	•	•
SC-PC07	Large Rubber Feet		•	•	NA	•	•	•	•	•	•	•	•	•	•	•
SC-0008	6mm Wing Screw	•				•	•	•	•	•	•	•	•	•	•	•

Hi-Hat Stand Parts

HI-HAT STAND PARTS AND ACCESSORIES

SC-1655-1

Hi-Hat Cup Washer

Flat metal washer fits under felt on hi-hat cup seat (1pk)



SC-HF2

Hi-Hat Cup Felts (2pk)



SC-CLF/4

Hi-Hat Clutch Felts (4pk)



SC-HR1

Rubber Hi-Hat Seat

Lasts longer than felts and enhances cymbal sustain (1pk)



SC-CLR/2

Rubber Hi-Hat Clutch (1pr)



SC-4980J

Hi-Hat Seat

Fits Gibraltar and most professional hi-hat stands with 1" or 5/8" tube (1pk)



SC-HHRM

Hi-Hat Pull Rod (Metric Threads)

Replacement hi-hat pull rod with metric m6 threads, 23" Long (1pk)



SC-HHRS

Hi-Hat Pull Rod (Standard Threads)

Replacement hi-hat pull rod with standard 1/4" - 20 threads, 23" Long (1pk)



SC-RP171

Hi-Hat Attachment Clamp

Attaches to bass drum counter hoop to support the hi-hat when used with double bass setup (1pk)

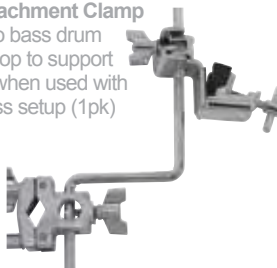

SC-RP171 Setup

SC-4421

Universal Hi-Hat Clutch

Fits most entry-level hi-hat stands (1pk)



SC-4421D

Standard Hi-Hat Clutch

Fits Gibraltar Rock series 5600 and 6600 and most moderate priced stands (1pk)



SC-4420

Pro Hi-Hat Clutch

Fits Gibraltar and most professional stands (8mm rods) (1pk)



SC-4420S

Super Hi-Hat Clutch

Utilizes our "Super Grip" clamping mechanism which will not scar the hi-hat pull rod. Fits 8mm rod (1pk)



SC-DC

Hi-Hat Drop Clutch

Disengage and drop top cymbal by hitting clutch with drumstick. Step on the pedal and clutch attaches itself at original position (1pk)



9707XB

X-Hi-Hat

Hi-hat attachment with gearless brake adjustment, 9.8" rod 12.7mm (1pk)



SC-XHHR

X-Hat

12.7mm Boom Rod only, mounts with grabber clamp to stand or eyebolt rack clamp *model SC-GRSRAA

NEW

SC-XHAT

Hi-Hat cymbal tilter attachment

Fits into 8mm cymbal tilter to add hi-hat on top of existing cymbal (1pk)



NEW

SC-GMP3MNT

iPod MP3 stand Mount

Mount your iPod or MP3 player to any stand. Fits tube diameters 5/8" to 1-5/8". 9" gooseneck with padded adjustable MP3 mount with position lock and back-up security tether.



SC-HHOTPK

Gibraltar's SC-HHOT Hi-Hat

Off Time Attachment mounts to your existing hi-hat stand adding an additional layer of rhythm to your sound. This attachment adds a second set of hi-hats to any brand of hi-hat, giving you a "chik" sound on the off beat when keeping time with your hi-hat foot. This really fills your sound out for all styles and grooves. Includes "Chik Hats"



Hand Percussion Mounting

MOUNTS AND ACCESSORIES

SC-4795-1

Cowbell U-Clamp

Standard "U" style clamp with wing screw to fit 9.5mm post on cowbell mount (1pk)



SC-EB

Eye Bolt Kit

Wing nut, washer and bolt set fits 9.5mm to 10.5mm posts (1pk)



SC-WCC

Wood Block / Cowbell Holder for Post Mount

Attaches to 9.5mm post mount for adding wood blocks and cowbells (1pk)



SC-RP269

WoodBlock / Cowbell Holder Bass Drum Hoop Mount

Dual purpose percussion mount clamps on a bass drum counter hoop. 9.5mm post for mounting cowbell and two mini L-Rods to mount woodblock (1pk)



SC-268R

Standard Cowbell Mount Bass Drum Hoop Mount

Mounts on bass drum counter hoop. 9.5mm (5/16") post with "U" clamp and wing screw (1pk)



SC-BDDC

Deluxe Cowbell Mount Bass Drum Hoop Mount

Heavy duty bass drum counter hoop clamp with 9.5mm post with "U" clamp and wing screw (1pk)



SC-BDHC

Adjustable Cowbell Mount Bass Drum Hoop Clamp

Clamps to bass drum counter hoop with adjustable 9.5mm L-Rod (1pk)



SC-4425D-1

Straight Tom / Percussion Cowbell Arm

7/8" dia post with an 9.5mm ratchet L-Rod for mounting cowbells, blocks, tambourines and other accessories. L-Rod also fits some tom mounts and electronic drums (1pk)



SC-170

Boom Tom / Percussion Cowbell Arm

7/8" dia post with adjustable boom and 9.5mm ratchet L-Rod for mounting cowbells, blocks, tambourines and other accessories (1pk)

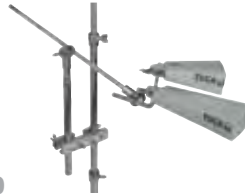

SC-LRAC

L-Rod Adjustment Clamp

9.5mm ratchet L-Rod for mounting percussion with adjustable stand clamp (1pk)



SC-DPLRA

Dual Post L-Rod Adjustment Clamp

Two 9.5mm posts in two lengths with adjustable stand clamp. Great for mounting two accessories together at different heights (1pk)



SC-PLRA

Percussion L-Rod Attachment

9.5mm ratchet L-Rod for mounting percussion with adjustable attachment mount (1pk)



SC-DPLAC

Dual Post L-Rod Attachment

Two 9.5mm posts in two lengths with adjustable attachment mount. Great for mounting two accessories together at different heights (1pk)



SC-TC

Triangle Clip Mount

Clothespin-style clamp for attaching triangle. Vinyl coated tip for a secure grip (1pk)



SC-DTC

Deluxe Triangle Holder Clamp (1pk)



SC-101

Tambourine Post Mount

Attaches to 9.5mm or 10.5mm post to mount most tambourines (1pk)



SC-DPLRA

SC-PLRA

SC-ABM

Agogo Bell Post Mount

Fits on 9.5mm or 10.5mm knurled post. Accommodates most manufacturers' mountable agogo bells (1pk)

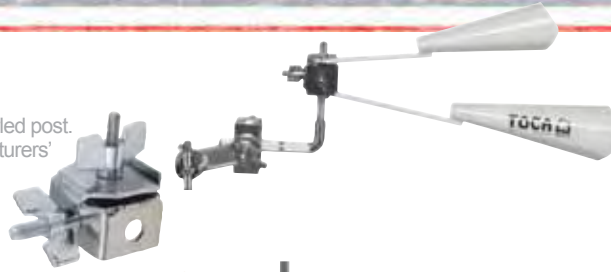

SC-SM

Shekere Clamp Mount

Allows for mounting of most shekeres so they can be played in mount (1pk)



SC-GM

Guiro Post Mount

Allows for most Toca, LP and other synthetic guiros via adjustable mounting system. Guiro can be played while mounted (1pk)



SC-CM

Cabasa Clamp Holder

Mounts cabasa for easy access. Can also be played while in mount. Fits on 1/2" to 1-1/2" dia tubes (1pk)



SC-CBPM

Cowbell Bass Drum Pedal Mount

Mounts cowbells, blocks, or tambourines to an adjustable floor stand which accepts most bass drum pedals (1pk)



SC-BST

Bongo Stand Top

The top section of a Gib 9616 Bongo Stand. Allows sturdy mounting of bongos to rack systems or double conga stands. Fits 1/2" to 1-1/2" dia. tubes or rack bars (1pk)



SC-BDCM

Bongo Double Conga Stand Mount

Attaches to any double conga stand to allow secure mounting of bongos. Clamping style bongo mount (1pk)



SC-WCM

Wind Chime Mount with Clamp

Mounts wind chimes with center hole with felts and wing nuts. Wind chime arm is held via eye bolt. Clamp section fits 1/2" to 1-1/2" dia tubes (1pk)



Percussion / Mic Mounting

PERCUSSION MOUNTS

SC-JCMTR
Tension Rod Cymbal Mount
Mounts cymbal to conga or bongo tension rod (1pk)

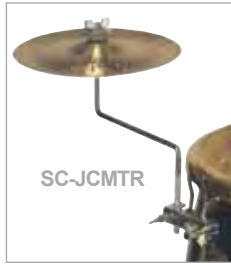

SC-CA
Cymbal Arm for AM Accessory Mounts
Mounts splash cymbal to AM accessory mounts (AM-1 and AM-4) (1pk)

SC-AM1
Single Post Accessory Mount Clamp
Attaches to stand to provide top or bottom mounting via 9.5mm post (1pk)

SC-AM4
4-Post Accessory Mount Clamp
Attaches to stand via cast mounting clamp and provides up to eight accessories top and bottom. 9.5mm posts (1pk)

SC-GRAPM
Rack Accessory Percussion Mount
Mounts percussion accessories on standard 1 1/2" rack bar.

SC-CPM
Cymbal Post Mount
Cymbal holder with heavy-duty tilter assembly and 8mm wing screw. Mounts on 9.5mm shaft (1pk)

SC-JPMTR
Tension rod percussion mount
Mounts perc to conga or bongo tension rod (1pk)

SC-JCM
Cymbal Mount
JAW mounts cymbal arm to hoop (1pk)

SC-JPM
Percussion Mount
JAW mounts perc post to hoop (1pk)

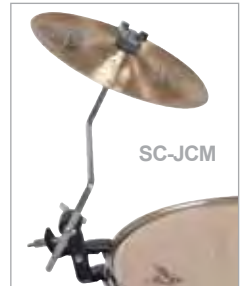

Gibraltar's "JAW" mounting clamps are designed to provide an easy uncluttered way of mounting various percussion instruments or microphones to drums, congas, bongos, and other instruments via their hoop or tension rods.

MICROPHONE MOUNTS

SC-GMQC
Microphone Quick Set Clamp Arm
A mounting mic arm with fast clamp that attaches to tubes up to 1.5-inch dia (1pk)

SC-GMBA
Short Mic Boom Arm
Black finish w/shock mount (1pk)

SC-GRMM
Rack Shock Microphone Mount
Mounts microphone right from your rack, comes with shock mount. No more mic stands!

SC-JMM
Mic Mount
JAW mounts microphone via drum hoop also works for guitar amp miking (1pk)

SC-JDRMM
Double Ratchet Mic Mount
JAW mounts microphone via drum hoop. Extra ratchet adjustment increases options (1pk)

SC-JPTRMM
Perc tension rod mic mount
JAW mounts microphone via conga or bongo tension rod (1pk)



Mounting / Accessories

MICROPHONE ACCESSORIES

SC-CBLMAN

Rack Cable Management Clips (2pk)



SC-VCW

Velcro Cord Wraps Black

Keeps cords organized and neat (4pk)



SC-GSM

Microphone Shock Mount

Prevents vibration transfer to microphone.

Fits standard mic holders and boom arms (1pk)



SC-GMCMA

Shock mount cymbal adaptor

Screws onto 8mm cym stand tilter

turning it into a microphone arm. (1pk)



SC-GBDIMM

Bass Drum Internal Microphone Mount

Mount attaches directly to the lug screws inside the bass drum shell. (1pk)



SC-DMM

Deluxe Microphone Mount

Nylon clamp fits standard tube

diameters with gooseneck mount. (1pk)



SC-MMMC

Multi Mount Microphone Clamp

Quick on and off variable size clamp with

gooseneck mount. Fits round or square tube diameters up to 1.5". (1pk)



SC-GGN

6" Black Microphone Gooseneck

Fits standard mic holders and boom arms (1pk)



GAB mounts utilize mounting platforms with a cast multi-clamp to guarantee secure and even mounting to cymbal stands and other fixed vertical tubes.

GAB-2

2-Post Accessory Mount Clamp

8" long, holds 4 items 9.5mm knurled posts (1pk)



GAB12

3-Post Accessory Mount Clamp

12" long, holds 6 items 9.5mm knurled posts (1pk)



GAB20

5-Post Accessory Mount Clamp

20" long, holds 10 items 9.5mm knurled posts (1pk)



SC-SAT

Accessory Table Small with Mount

Attaches to a cymbal stand or rack bar. 12" x 12" with 1" high border and padded surface (1pk)



SC-MAT

Accessory Table Medium

Attaches to cymbal stand or rack bar. 12" x 18", with 1" high border and padded surface (1pk)



GAB-2

Gibraltar Artists

Additional Artists

Trent Anderson
 Remy Antoun
 Demian Arriago
 Kevin Bacon
 Beaver
 Cyro Baptista
 Pablo Batista
 Pierre Belleville
 Roger Biwando
 Randy Black
 Brendan Buckley
 Mario Calire
 Clayton Cameron
 Joe Clegg
 Mike Clemons
 Yann Coste
 Oscar D'Auria
 Rian Dawson
 Jeroen De Rijk
 Chet Doboie
 Mario Duplantier
 François Ernie
 Patrick Fa
 Zac Farro
 Stan Frazier
 Dan Flint
 Richie Gajate-Garcia
 Doc Gibbs
 Justin Graves
 Jim Greiner
 Patrick Grün
 Tony Hammons
 Brent Harris
 Taylor Hawkins
 Andy Herrick
 Bryan Hitt
 Davy Honnet
 John Jenkins
 Philip Jenkins
 Bashiri Johnson
 Claus Andre Larsen
 Paul Mason
 Gavin McDonald
 Cam McGlinchey
 Russ McKinnon
 Dave Mette
 John Miceli

Bang Tango
 Seal
 Jonas Brothers
 The Bacon Brothers
 D4
 Independent
 Alicia Keys
 The Do
 Independent
 Primal Fear
 Shakira
 Independent
 Tony Bennett
 Ellie Goulding
 Israel & New Breed
 No One Is Innocent
 Independent
 All Time Low
 Independent
 Hip Pickles
 Gojira
 Stuck in the Sound
 Stefanie Heinzmann
 Novel American
 Sugar Ray
 You Me At Six
 Independent
 Independent
 A Life Once Lost
 Clinician
 Caliban
 Montgomery Gentry
 Cut Off Your Hands
 Foo Fighters
 Chimaira
 REO Speedwagon
 Independent
 Lily Allen
 Kids in Glass Houses
 Whitney Houston
 Briskeby
 The Body Rockers
 Paper Route
 Rogue Traders
 Barry Manilow
 Philipp Poisel
 Meatloaf



Chris Adler
Lamb of God



Creighton Barrett
Band of Horses



Rich Beddoe
Finger Eleven



John Boeklin
DevilDriver



Nicky Bomba
John Butler Trio



Rob Bourdon
Linkin Park



Karl Brazil
Robbie Williams



Peter Carlsson
Carolina Liar



Lenny Castro
Stevie Nicks



Chris Cester
Jet



Hiroshi Chu Okubo
Independent



Vinnie Colaiuta
Independent/Studio



Luis Conte
James Taylor



M. Shawn "Clown"
Crahan
Slipknot



Shawn Drover
Megadeth



Stefanie Eulinberg
Kid Rock



Steve Ferrone
Tom Petty &
The Heartbreakers



Mika Fineo
Filter



Hannah Ford
Peace, Love & Drums



Greg Garman
Selena Gomez & The
Scene



Rex Hardy
American Idol



Clint Hyndman
Something for Kate



Tris Imboden
Chicago



Caitlin Kalafus
Kicking Daisies



Derek Kerswill
Tangents

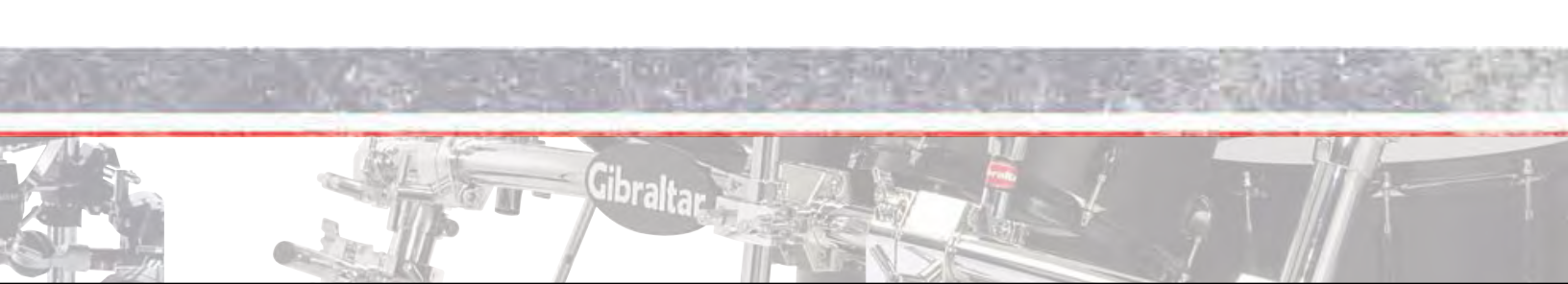

Thomas Lang
Independent



David Lauser
Sammy Hagar



Greg Lohman
Kellie Pickler



Ryan MacMillan
Matchbox Twenty



Samantha Maloney
Independent



Jonathan Moffett
Cameo



John Paris
Earth, Wind & Fire



Karl Perazzo
Santana



Scott Phillips
Creed



Nick Price
Meg & Dia



Aquiles Priester
Hangar, Freakykeys



Kevin Ricard
Independent



Bill Rieflin
REM



Jim Riley
Rascal Flatts



Van Romaine
Enrique Iglesias,
Steve Morse



Pato Sandoval
Morbid Angel



Terry Santiel
Justin Timberlake



Mark Schulman
PINK



Ty Smith
Easton Corbin



Jeremy Spencer
Five Finger Death
Punch



Chester Thompson
Genesis



Yutaka Watanabe
Independent



Alan White
Yes



Rick Woolstenhulme,
Jr.
Lifehouse



Ryan Yerdon
Puddle of Mudd

Additional Artists

Mike Montgomery
Cameron Morris
Rafael Padilla
Pete Parada
Ryan Parrish
Tiki Pasillas
Roland Peil
Daren Pfeifer
Slim Jim Phantom
Corey Pierce
Felix Pollard
Gregg Potter
Chris Powell
Ron Powell
Seth Rausch
Land Richards
Marshall Richardson
Forrest Robinson
Bart Robley
Rob Rolfe
Bobby Rondinelli
Paul Roper
C.G. Rychie
Ralph Salmans
Lou Santiago, Jr.
Dusty Saxton
Christoph Schneider
Tom Schofield
Nathaniel Scott
Zach Simms
Travis L. Smith
Derrick Sorrell, Jr.
Joel Spencer
Rick Steel
Martin Stoeck
Crystal Tallifero
Dena Tauriello
Christian Vander
Nicolas Viccaro
Matt Walker
Bill Ward
Sammy J. Watson
Tommy Wells
Al Wilson
Damon Wilson
Steven Wolf
Jarred Wrennell
Nir Z.

iwrestleabearance
Dommin
Shakira
The Offspring
Darkest Hour
Marc Anthony
Die fantastischen 4
Hollywood Undead
Stray Cats
God Forbid
Clay Aiken
Super Mercado
Jamey Johnson
Madonna
Joe Nichols
Independent
Jo Dee Messina
Independent
Sam Morrison Band
Enter Shikari
Black Sabbath
Mint Chicks
Independent
UK Studio
Independent
Alpha Rev
Rammstein
Soil
Rob Mullins
Independent
Independent
Ne-Yo
Independent
Independent
Pur
Billy Joel
Antigone Rising
Magma
Etienne M Bappe
Morrissey
Black Sabbath
Mt. Helium
Nashville Studio
Taylor Swift
Ray Davies
Independent
Steriogram
Independent

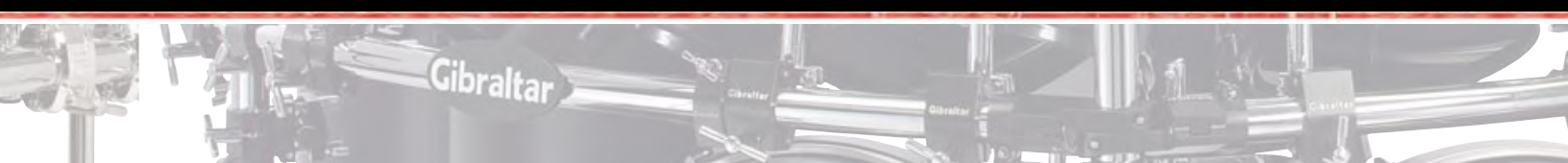



Gibraltar
HARDWARE

**INTRODUCING
GIBRALTAR
ROLLING
RACKS**

THIS IS HOW WE ROLL!

2011 International Award Winner for Best Hardware

Gibraltar

L I G H T & Q U I C K



**Gearless
Brake
Tilter**

*smooth
gearless
positioning
with drum
key lock*



swing open

mount cymbal

swing closed

*the revolutionary
Swing Nut makes
cymbal mounting FAST
with fully adjustable
spring-loaded action*

**L-Bar
Aluminum
ArrowLite
Legs**

*Gibraltar reinvents
the double-braced leg-
strong, lightweight
and beautiful!*



*style and function -
no metal-to-metal contact
& wing adjust memory lock*

**SuperLock Hinged
Height Adjustment**



and introducing

**THE
SWING
NUT**

patent pending



www.Gibraltarhardware.com

<http://forums.gibraltarhardware.com>

<http://diy.gibraltarhardware.com>

www.facebook.com/gibraltarhardware

www.myspace.com/gibraltardrumhardware

www.flickr.com/groups/gibraltarhardware

www.youtube.com/gibraltardiy

KMC Music, Bloomfield, CT 06002

