



MEINL

1 This is MEINL

- 2 The MEINL Cymbal Series
- 5 The Sounds, The Bronzes, The Voices

8 Six Degrees of Darkness

- 10 Byzance Traditional
- 12 Byzance Vintage
- 14 Byzance Jazz
- 16 Byzance Extra Dry
- 18 Byzance Dark
- 20 Byzance Brilliant

22 Modern

- 24 M-Series Fusion
- 26 M-Series Traditional
- 28 Soundcaster Fusion
- 30 Soundcaster Custom

32 Aggressive

- 34 Mb20
- 36 Mb10
- 38 Mb8

40 Clarity and Cut

- 42 Classics Traditional
- 44 Classics Custom
- 46 Classics Custom Extreme Metal

48 Innovation

- 50 Generation X

52 First Step

- 54 MCS
- 56 HCS

58 Drum Gear and Percussion

- 59 Jawbreaker Collection
- 60 Cymbal Bags and Cases
- 64 Stick Bags and Holders
- 65 Practice Pads
- 66 Drum Rugs
- 67 Hardware, Gloves, Cleaners, Gig Towel, Tour Trolley
- 68 Laptop Table, Turbo Crasher, E-Drum Rug
- 70 Cowbells
- 72 Timbales, Blocks
- 73 Tambourines

74 More Than Just Cymbals

76 Merchandise

... Not Like Everybody Else.

One of the great things about being a drummer is the opportunity to be different...to be yourself. When you listen to all the greats, they're not like everybody else. They're themselves. We like that.

Today it is difficult to be totally original or 100% unique, but that does not mean you must be like all the others. At MEINL we do our own thing. That's just who we are; and we like to think you want to be who you are too. There's a freedom that comes with that.

Maybe you know that we are also drummers? So when we say MEINL is 'By drummers, for drummers', we mean it. We are also always looking to create new things for drummers and better ways to do that, so there is a lot of innovation in what we do and how we do it. As you will see on the following pages, MEINL innovations aren't limited to just designing new cymbals. No, they extend to how those cymbals are made, the fact that we are the first to use four types of bronze and that we also offer such a wide variety of traditional and modern sounds. Of course we respect tradition, but really the future is where we are going.

But the greatest thing for all of us at MEINL is the friendships we share with drummers, and the trust they put in us. To us, that is our greatest achievement to date.

Possibly all of this makes MEINL that little bit different. But then like you we are drummers, and drummers are not like everybody else.



THE MEINL CYMBAL SERIES

Six Degrees of Darkness



Byzance

- TRADITIONAL
- VINTAGE
- JAZZ
- EXTRA DRY
- DARK
- BRILLIANT

Modern



M
M-SERIES
— FUSION —

M
M-SERIES
— TRADITIONAL —

Sound
caster
FUSION

Sound
caster
CUSTOM

Aggressive



Mb²⁰

Mb¹⁰

Mb⁸

Clarity and Cut



CLASSICS

CLASSICS
— CUSTOM —

CLASSICS
CUSTOM
EXTREME METAL SERIES

Innovation



9 generation X

First Step



MCS

HCS



THE SOUNDS

Darker sounds blend with the music, brighter ones cut through. Many players mix them together.

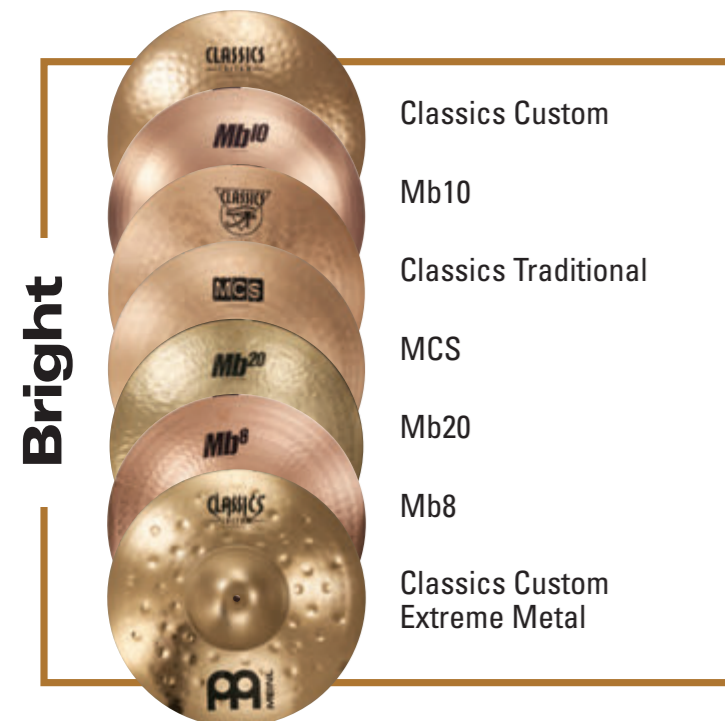

THE BRONZES

Only MEINL offers four bronzes. High numbers deliver more tone; lower ones sound brighter and tonally tighter.



THE VOICES

Insight from inside MEINL

“We walk to the edge of the creative cliff and jump . . .”

The Series

With the various MEINL cymbal series there are many models and sounds to choose from. Drummers tell us this choice lets them find the musical freedom they need to grow as musicians. Many of these players are taking drumming in new directions, and say the inspiration they get from playing – and hearing – our cymbals has triggered their creativity to the point where MEINL is now part of their musical culture. This feedback inspires us to explore new ideas, because everything that is important to drummers is important to us.

– Norbert Saemann, Director of AR (Worldwide)

The Players

Players know that with MEINL they will find cymbals that give them a voice of their own; a voice that separates them from the rest of the pack, inspires and furthers their playing and let's them be themselves. They know MEINL is different too, because we really care about players and do what we can to ensure they have those sounds. Probably the greatest thing is to watch fellow drummers who play and are inspired by our cymbals, inspire future generations of players. Being able to help make that happen is a very cool thing.

– Chris Brewer, Artist Relations (North America)



The Bronzes

Sometimes we walk to the edge of the creative cliff and jump. When we do, it can be months of thinking, designing, testing and trial and error before we land on something we feel is worth developing into a model or series. Our focus is on sounds, feels, finishes and metal types before we even test the cymbal prototypes, which is why only MEINL offers cymbals in four types of bronze. We treat it all like rocket science, because for us and for those players who rely on MEINL, it is very important that everything be as right as possible.

– Stefan Mueller, Product Manager MEINL Cymbals

The Sounds

If you know MEINL, then you will know our search for new sounds – traditional, modern and innovative – is never ending. We are constantly looking and listening to what is happening with music and drummers, getting ideas and turning them into cymbals and sounds. That is why this catalog contains so many types of cymbals. After all, if you really want to be yourself as a player, it's great to have your own sound. With MEINL you can do that. From dark to bright, to soft and simmering or even loud and louder, they are all on these pages.

– Stephan Haenisch, Artist Relations (Germany)

“Everything that is important to drummers is important to us.”

THE CYMBALS

Hand hammered cymbals created for today's music. And ultra-modern designs that give drummers more sounds to choose from. Between our traditional foundry in Turkey and our state-of-the-art facility in Germany, we do it all. Cymbals, sounds and beyond... just turn this page.



Jawbreaker

Wherever you see this logo, you know those cymbals are louder than all the rest.



MIPA

(musikmesse international press award)
Every year, editors from over 100 leading music magazines vote for the best new musical instruments and award them a MIPA. Meinl Cymbals is a consistent winner.

Byzance

SIX DEGREES OF DARKNESS

One-of-a-Kind

The warm darkness of traditional hand hammered cymbals is re-imagined with Byzance. Each range is hand crafted by MEINL artisans at our foundry in Turkey, then given sound-enhancing final touches by our craftsmen in Germany. Six different ranges offer a choice of feels and sounds for virtually every style of music. Best of all, with Byzance your sound is all yours, because every Byzance cymbal is a one-of-a-kind.



Byzance

TRADITIONAL

Dark Warmth

Their hammered and lathed surfaces, warm sounds and selection of models may be very traditional, but these cymbals are the ultimate choice when it comes to versatility. Rides with a buttery-soft feel. Crashes that range from dark and shimmering with thin models, to powerful and focused with heavier ones. Traditional tone and sonic individuality come together in each of these cymbals.

THE CYMBALS



SPLASHES	
6" B6S	
8" B8S	
10" B10S	
12" B12S	
CHINAS	
14" B14CH	
16" B16CH	
18" B18CH	
20" B20CH	
22" B22CH	
FLAT CHINAS	
16" B16FCH	
18" B18FCH	
MINI HATS	
10" B10MH	
12" B12MH	
HIHATS	
Thin	
14" B14TH	
Medium	
13" B13MH	
14" B14MH	
15" B15MH	
16" B16MH	
Heavy	
14" B14HH	
CRASHES	
Thin	
14" B14TC	
15" B15TC	
16" B16TC	
17" B17TC	
18" B18TC	
Medium Thin	
16" B16MTC	
17" B17MTC	
18" B18MTC	
19" B19MTC	
Medium	
16" B16MC	
18" B18MC	
20" B20MC	
21" B21MC	
22" B22MC	
Heavy	
16" B16HC	
18" B18HC	
EXTRA THIN HAMMERED CRASHES	
18" B18ETHC	
20" B20ETHC	

RIDES	
Medium	Heavy
20" B20MR	20" B20HR
21" B21MR	21" B21HR
22" B22MR	22" B22HR
23" B23MR	23" B23HR
24" B24MR	

SIZZLE RIDE	
Medium	
20" B20MR-S	

PING RIDES	
20" B20PR	
22" B22PR	



Byzance

VINTAGE

Dark Shimmer

Its unusual sandblasted surface gives it a soft feel and a distinct matte finish. Its low, dark and somewhat dry washy sound isn't too soft or loud. With its great stick definition and short sustain, you can dig into Byzance Vintage for total control at all times. It's a sound that fits into any music that isn't in the upper decibel levels.



THE CYMBALS

TRASH CRASHES

- 16" B16TRC
- 18" B18TRC
- 20" B20TRC **NEW!**



VINTAGE CRASHES

- 16" B16VC **NEW!**
- 18" B18VC **NEW!**
- 20" B20VC
- 22" B22VC



BENNY GREB SIGNATURE SAND MODELS

SAND HAT

- 14" B14SAH



NEW! SAND CRASHES

- Thin**
18" B18SATC
- Medium**
18" B18SAMC



NEW! SAND CRASH-RIDE

- 22" B22SACR



SAND RIDES

- 20" B20SAR
- 22" B22SAR



NEW! SAND CYMBAL SET

- BV-141820SA
- 14" Sand Hat
- 18" Sand Thin Crash
- 20" Sand Ride



METAL **B20 BRONZE** SHAPING Hand Hammered LATHE Narrow Blade FINISH Sandblasted SOUND Dark, Dry STYLES Pop, Fusion, Jazz, Funk, R&B, Reggae, Studio, World, Electro TO CLEAN Not recommended

Byzance

JAZZ

Dark Tonality

Byzance Jazz. The touch and tone of these cymbals, with their soft, buttery, sink-your-stick feel and low, dark tonalities, add up to a very personalized sound. A closer look at the hammering on some models reveals large and deep dimpling that boosts dryness and darkness.

THE CYMBALS



SPLASH		
10" B10JS		
HIHATS		
Thin		
13" B13JTH		
14" B14JTH		
CRASHES		
Extra Thin		
16" B16JETC		
17" B17JETC		
18" B18JETC		
Thin		
16" B16JTC		
17" B17JTC		
18" B18JTC		
Medium Thin		
16" B16JMTC		
17" B17JMTC		
18" B18JMTC		
CHINA RIDE		
22" B22JCHR		
RIDES		
Extra Thin		
20" B20JETR		
22" B22JETR		
Thin		
20" B20JTR		
22" B22JTR		
Medium Thin		
20" B20JMTR		
22" B22JMTR		
Medium		
20" B20JMR		
22" B22JMR		
SWEET RIDES		
Sweet Light		
20" B20JSLR		
Sweet		
20" B20JSR		
BIG APPLE RIDE		
22" B22JBAR		

FLAT RIDE		
20" B20JFR		
CLUB RIDES		
20" B20JCR		
22" B22JCR		
Wolfgang Haffner's signature cymbals		

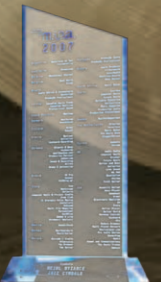

MIPA Winner
Byzance Jazz



Byzance

EXTRA DRY

Dark Definition

Living up to their name, these cymbals are extremely dry, with low-pitched, trashy sounds and short sustain. The raw unlathed surfaces and extensive hand hammering suggest that their sound might be loud and fierce. In reality, the Extra Dry series reveals its dark, earthy tones and comes to life when played at lower volumes.

THE CYMBALS

SPLASH

10" B10EDS



CHINAS

18" B18EDCH
20" B20EDCH



HIHATS

Medium
13" B13EDMH
14" B14EDMH



CRASHES

Thin
16" B16EDTC
18" B18EDTC
20" B20EDTC



RIDES

Thin **NEW!**
22" B22EDTR
Medium
20" B20EDMR
22" B22EDMR



Byzance



DARK

Dark Intensity

Their sound is dark, and so is their oven-blackened look. Byzance Dark models are intense, with responses ranging from the defined sticking of the rides, to the short, punchy bursts of the crashes. Their unique sonic qualities are ideal for music where dark tone and feel are at the top of the 'must have' list.

THE CYMBALS



SPLASHES	8" B8DAS 10" B10DAS	
CHINA	18" B18DACH	
HIHATS	13" B13DAH 14" B14DAH 15" B15DAH	
SPECTRUM HIHATS	13" B13SH 14" B14SH Rodney Holmes' signature cymbals	
CRASHES	16" B16DAC 17" B17DAC 18" B18DAC	
RIDES	20" B20DAR 21" B21DAR 22" B22DAR	
RAW BELL RIDES	20" B20RBR 22" B22RBR	
SPECTRUM RIDE	22" B22SR	

STADIUM RIDE	22" B22STR	
	Trevor Lawrence Jr's signature cymbal	
SKY RIDE	19" B19SKR	
	Noriaki Kumagai's signature cymbal	



METAL **B20** BRONZE | SHAPING Hand Hammered | LATHE Abraded | FINISH Dark | SOUND Mid-Dark, Earthy | STYLES Pop, Fusion, Jazz, Funk, R&B, Reggae, Studio, World, Electro | TO CLEAN MEINL Cymbal Cleaner



Byzance

BRILLIANT

THE CYMBALS

Dark Brightness

Though 'Brilliant' refers to its finish, this series actually takes the traditional Byzance and darkens its sound. This darker sound is due to a finishing process that limits the high end as the cymbal is buffed to its brilliant look. Heavier models penetrate with directness, thinner ones shimmer with warmth. The overall combination of dark tonality and warm spread make Byzance Brilliant a great choice for everything from funk and fusion to rock.



SPLASHES		
6"	B6S-B	
8"	B8S-B	
10"	B10S-B	
12"	B12S-B	
CHINAS		
14"	B14CH-B	
16"	B16CH-B	
18"	B18CH-B	
20"	B20CH-B	
HIHATS		
Medium		
13"	B13MH-B	
14"	B14MH-B	
Heavy		
14"	B14HH-B	
FAST HIHATS		
13"	B13FH	
14"	B14FH	
Thomas Lang's signature cymbals		
SERPENTS HIHAT		
13"	B13SH-B	
Derek Roddy's signature cymbal		
CRASHES		
Thin		
14"	B14TC-B	
15"	B15TC-B	
16"	B16TC-B	
17"	B17TC-B	
18"	B18TC-B	
Medium Thin		
16"	B16MTC-B	
17"	B17MTC-B	
18"	B18MTC-B	
19"	B19MTC-B	
Medium		
16"	B16MC-B	
18"	B18MC-B	
20"	B20MC-B	
RIDES		
Medium		
20"	B20MR-B	
21"	B21MR-B	
22"	B22MR-B	
24"	B24MR-B	
Heavy		
20"	B20HR-B	
22"	B22HR-B	
SERPENTS RIDE		
21"	B21SR-B	
Derek Roddy's signature cymbal		



SHAPING
Hand Hammered

LATHE
Narrow Blade

FINISH
Brilliant

SOUND
Mid-Bright, Tonally Rich

STYLES
Rock, Pop, Fusion, Funk, R&B, Reggae, Studio

TO CLEAN
MEINL Cymbal Polish



Brighter Sounds

While traditional cymbal making covers the warmer, darker end of the sound spectrum, it takes modern cymbal making technology to create brighter, glassier sounds. With M-Series and Soundcaster those qualities come to life through unique sounds and stunning looks.

MODERN



Modern Versatility

The design may grab your attention first, but the sound is the real winner here. With two very distinct playing surfaces, M-Series Fusion is all about being fast and versatile. A wide, thinner edge that responds with sensitivity and speed. A denser bow area for increased sticking clarity. A lathed and polished bell for bright definition. All of these characteristics result in a level of tonal brilliance that makes these cymbals 'sing.'

M
M-SERIES
FUSION



SPLASH

10" MS10FS



HIHAT

Medium
 14" MS14FMH



CRASHES

Medium
 16" MS16FMC
 18" MS18FMC



RIDES

Medium
 20" MS20FMR
 22" MS22FMR



Modern Traditional

This selection of medium and heavy models combines traditional B20 bronze with modern technology, resulting in crisp mid-range responses. Great for rock, pop and r & b, where a clarity and consistency of every stroke is what you need. M-Series Traditional is a modern concept built on traditional sounds.

M
M-SERIES
— TRADITIONAL —



BELL
8.5" MS85B



SPLASH
10" MS10S



HIHATS
Medium
13" MS13MH
14" MS14MH
Heavy
14" MS14HH



CRASHES
Medium
15" MS15MC
16" MS16MC
17" MS17MC
18" MS18MC
Heavy
16" MS16HC
18" MS18HC



RIDES
Medium
20" MS20MR
22" MS22MR
Heavy
20" MS20HR



Modern Tone

The name is the giveaway. This range is a fusion of two different playing surfaces and sounds. Their micro hammering and semi-lathed surface gives them a shorter sustain and a slightly darker mid-range tone. Soundcaster Fusion's versatility lets you dig in, be heard and play most any style of music.



SPLASHES

- 8" SF8S
- 10" SF10S



CHINAS

- 16" SF16CH
- 18" SF18CH
- 20" SF20CH



HIHATS

- Medium**
- 13" SF13MH
 - 14" SF14MH



CRASHES

- Thin**
- 16" SF16TC
 - 18" SF18TC



- Medium**
- 14" SF14MC
 - 16" SF16MC
 - 17" SF17MC
 - 18" SF18MC

- Powerful**
- 16" SF16PC
 - 18" SF18PC
 - 19" SF19PC
 - 20" SF20PC

TRASH CRASHES

- 16" SF16TRC
- 18" SF18TRC



RIDES

- Thin**
- 20" SF20TR

- Medium**
- 20" SF20MR

- Powerful**
- 20" SF20PR
 - 22" SF22PR



MATCHED CYMBAL SET

- SF-141620M
- 14" Medium Hihat
- 16" Medium Crash
- 20" Medium Ride
- FREE** 22" Pro Cymbal Case

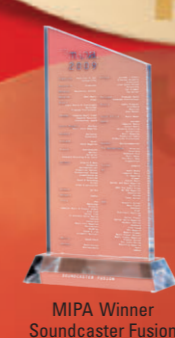

MIPA Winner
Soundcaster Fusion



METAL



SHAPING

Computerized Hammering

LATHE

Pinpoint

FINISH

Traditional & Brilliant

SOUND

Mid-Dark, Warm

STYLES

Rock, Pop, Fusion, R&B, Reggae, Studio

TO CLEAN

MEINL Cymbal Cleaner

Modern Brilliance

With a brilliant finish that highlights a hammered and lathed surface, Soundcaster Custom's B12 bronze gives these cymbals the flexibility to absorb solid stick hits and still sound great. They deliver solid lows, warm mids and boosted highs. Their dynamic range and musical muscle enables these cymbals to cut through most any style of music.



THE CYMBALS

SPLASHES

- 6" SC6S-B
- 8" SC8S-B
- 10" SC10S-B
- 12" SC12S-B



DISTORTION SPLASH

- 12" SC12DS-B

CHINAS

- 16" SC16CH-B
- 18" SC18CH-B
- 20" SC20CH-B



HIHATS

- Medium**
- 13" SC13MH-B
 - 14" SC14MH-B
- Powerful**
- 14" SC14PH-B

SOUNDWAVE HIHATS

- Medium**
- 14" SC14MSW-B
- Powerful**
- 14" SC14PSW-B

CRASHES

- Thin**
- 16" SC16TC-B
 - 18" SC18TC-B
- | | |
|---------------|-----------------|
| Medium | Powerful |
| 14" SC14MC-B | 16" SC16PC-B |
| 15" SC15MC-B | 17" SC17PC-B |
| 16" SC16MC-B | 18" SC18PC-B |
| 17" SC17MC-B | 19" SC19PC-B |
| 18" SC18MC-B | 20" SC20PC-B |



RIDES

- Medium**
- 20" SC20MR-B
- Powerful**
- 20" SC20PR-B
 - 21" SC21PR-B
 - 22" SC22PR-B



MEGA BELL RIDE

- 22" SC22MBR-B



MATCHED CYMBAL SET

- SC-141620M
- 14" Medium Hi-hat
- 16" Medium Crash
- 20" Medium Ride
- FREE** 22" Pro Cymbal Case



AGGRESSIVE METALS

Mb10

Mb20



Mb8

Three Levels of Aggression

Three different cymbals, created from three different metals, producing three different sounds, have one thing in common: Their bright responses are aggressive! Mb20 is powered by thick bronze for maximum projection. Mb10 delivers a more focused degree of cut. Mb8 slices through with a direct response. This trio delivers three levels of aggression designed to cut through the loudest music.

Mb20

Hand Hammered Aggression

When we decided it was time for a B20 hand hammered cymbal that could cut it in rock and metal, we designed Mb20. These cymbals combine musicality and volume in a range of medium-heavy and heavyweight models for maximum projection. Slightly dark and completely in your face, Mb20 is a great example of how we are repurposing hand hammered cymbals for today's music.



THE CYMBALS

ROCK SPLASHES

- 10" MB20-10RS-B
- 12" MB20-12RS-B



ROCK CHINAS

- 18" MB20-18RCH-B
- 20" MB20-20RCH-B



HIHATS

- Heavy Soundwave
- 14" MB20-14HSW-B
- 15" MB20-15HSW-B



CRASHES

- Medium Heavy
- 16" MB20-16MHC-B
- 18" MB20-18MHC-B
- 20" MB20-20MHC-B



Heavy

- 16" MB20-16HC-B
- 17" MB20-17HC-B
- 18" MB20-18HC-B
- 19" MB20-19HC-B
- 20" MB20-20HC-B
- 22" MB20-22HC-B

RIDES

- Medium Heavy
- 20" MB20-20MHR-B
- Heavy
- 20" MB20-20HR-B
- 21" MB20-21HR-B
- 22" MB20-22HR-B



HEAVY BELL RIDES

- 20" MB20-20HBR-B
- 22" MB20-22HBR-B



PURE METAL RIDE

- 24" MB20-24PMR-B

Chris Adler's signature cymbal

With **FREE** 24" Chris Adler Artist Series Cymbal Bag



TO CLEAN
MEINL Cymbal Polish

METAL **B20 BRONZE** SHAPING Hand Hammered LATHE Narrow Blade FINISH Brilliant SOUND Bright, Aggressive STYLES Metal, Rock, Studio

Mb10

Cutting Aggression

With its punchy response and bright, glassy tone, Mb10 is yet another innovation from the MEINL R&D team. We introduced B10 bronze (90% copper, 10% tin) so drummers would have another fresh sound to add to their set-up. Shaped by computerized hammering and buffed to a brilliant finish, Mb10 is extremely durable and responds with a glassy shimmer that cuts with aggression.



THE CYMBALS

SPLASHES

- 8" MB10-8S-B
- 10" MB10-10S-B
- 12" MB10-12S-B



CHINAS

- 17" MB10-17CH-B
- 19" MB10-19CH-B



SOUNDWAVE HIHATS

- Medium**
- 14" MB10-14MSW-B
 - 15" MB10-15MSW-B



- Heavy**
- 14" MB10-14HSW-B

FAT HAT

- 16" MB10-16FH-B

Flo Dauner's signature cymbal



CRASHES

- Thin**
- 16" MB10-16TC-B
 - 18" MB10-18TC-B



- Medium**
- 14" MB10-14MC-B
 - 15" MB10-15MC-B
 - 16" MB10-16MC-B
 - 17" MB10-17MC-B
 - 18" MB10-18MC-B
 - 19" MB10-19MC-B
 - 20" MB10-20MC-B
- Heavy**
- 16" MB10-16HC-B
 - 18" MB10-18HC-B
 - 20" MB10-20HC-B
 - 21" MB10-21HC-B

RIDES

- Medium**
- 20" MB10-20MR-B
 - 21" MB10-21MR-B



- Heavy**
- 20" MB10-20HR-B
 - 22" MB10-22HR-B



MATCHED CYMBAL SET

- MB10-141620M
- 14" Medium Soundwave Hihat
- 16" Medium Crash
- 20" Medium Ride
- FREE** 22" Pro Cymbal Case



Mb8

Focused Aggression

B8 alloy delivers the tightest, most tonally focused and direct sounds of our four bronzes. This means Mb8 cymbals sound very bright, loud, tight and cutting. There is no lush warmth here. Crashes are fast and punchy, while rides and hats deliver with clarity. Such direct and penetrating sounds – as well as a very nice price – make Mb8 a favorite for rock and metal.

THE CYMBALS

SPLASHES

- 8" MB8-8S-B
- 10" MB8-10S-B
- 12" MB8-12S-B



CHINAS

- 16" MB8-16CH-B
- 18" MB8-18CH-B
- 20" MB8-20CH-B



MINI HAT

- 10" MB8-10MH-B



HIHATS

- Medium**
- 13" MB8-13MH-B
 - 14" MB8-14MH-B



- Heavy**
- 14" MB8-14HH-B

CRASHES

- Medium**
- 14" MB8-14MC-B
 - 16" MB8-16MC-B
 - 17" MB8-17MC-B
 - 18" MB8-18MC-B
 - 19" MB8-19MC-B
 - 20" MB8-20MC-B



- Heavy**
- 16" MB8-16HC-B
 - 18" MB8-18HC-B
 - 20" MB8-20HC-B

RIDES

- Medium**
- 20" MB8-20MR-B
 - 22" MB8-22MR-B



- Heavy**
- 20" MB8-20HR-B
 - 22" MB8-22HR-B

GHOST RIDE

- 21" MB8-21GR

Brann Dailor's signature cymbal



EFFECT CYMBAL SET

- MB8-10/18
- 10" Splash
- 18" China
- FREE** Cymbal Attachment



MATCHED CYMBAL SET

- MB8-141620M
- 14" Medium Hihat
- 16" Medium Crash
- 20" Medium Ride
- FREE** 22" Pro Cymbal Case

METAL



SHAPING

Computerized Hammering

LATHE

Wide Blade

FINISH

Brilliant

SOUND

Bright, Explosive

STYLES

Metal, Rock, Pop, Studio

TO CLEAN

MEINL Cymbal Cleaner



CLARITY AND CUT

Loud. Louder. Loudest. From the loud Classics, to the louder Classics Custom to the loudest, Classics Custom Extreme Metal, this trio of innovative cymbals is all about high-energy response. These cymbals add pure punch wherever clarity and cut are a must. Ideal for pop, rock, and the most brutal metal imaginable, all three will get you heard.



LOUD!



LOUDER!!



LOUDEST!!!



Powered by bright, widely lathed B8 bronze, this nicely priced series is great for cutting through most volumes. With explosive crash responses and glassy ride definition, Classics models may not be as powerful as the very different Custom or Extreme Metal, but their ability to project is unquestionable.

LOUD!



BELLS		
8"	C8BL	Low
8"	C8BM	Medium
8"	C8BH	High
SPLASHES		
8"	C8S	
10"	C10S	
12"	C12S	
CHINA SPLASHES		
8"	C8CS	
10"	C10CS	
CHINAS		
12"	C12CH	
14"	C14CH	
16"	C16CH	
18"	C18CH	
MINI HAT		
10"	C10MH	
HIHATS		
Medium		
13"	C13MH	
14"	C14MH	
Powerful		
14"	C14PH	
SOUNDWAVE HIHATS		
Medium		
14"	C14MSW	
Powerful		
14"	C14PSW	
CRASHES		
Thin		
16"	C16TC	
18"	C18TC	
Medium		Powerful
14"	C14MC	16" C16PC
15"	C15MC	17" C17PC
16"	C16MC	18" C18PC
17"	C17MC	
18"	C18MC	
20"	C20MC	
RIDES		
Medium		
20"	C20MR	
21"	C21MR	
22"	C22MR	
Powerful		
20"	C20PR	



CLASSICS

— CUSTOM —

LOUDER!!

Made with B10 bronze, Classics Custom models pack a loud and bright punch that gets you heard clearly in every style of music. Designed to cut above the roar of guitars, these cymbals do most of the work for you, so you don't have to play as hard to be heard. With great stick response on the rides and hats, you can dig in and groove, while the crashes deliver powerful accents.



THE CYMBALS

NEW! BELL	8" CC8B-B	
SPLASHES	8" CC8S-B 10" CC10S-B 12" CC12S-B	
TRASH SPLASH	12" CC12TRS-B	
CHINAS	16" CC16CH-B 18" CC18CH-B	
NEW! TRASH CHINAS	16" CC16TRCH-B 18" CC18TRCH-B	
HIHATS	Medium 14" CC14MH-B 15" CC15MH-B Powerful 14" CC14PH-B	
CRASHES	Medium 14" CC14MC-B 15" CC15MC-B 16" CC16MC-B 17" CC17MC-B 18" CC18MC-B Powerful 16" CC16PC-B 18" CC18PC-B	
TRASH CRASHES	16" CC16TRC-B 18" CC18TRC-B	
RIDES	Medium 20" CC20MR-B Powerful 20" CC20PR-B 22" CC22PR-B	



MATCHED CYMBAL SET
 CC-141620M
 14" Medium Hihat
 16" Medium Crash
 20" Medium Ride
FREE 22" Pro Cymbal Case



CLASSICS CUSTOM

EXTREME METAL SERIES

Brutally loud and intense, Classics Custom Extreme Metal models are totally effective when it comes to projecting through the loudest and most aggressive music there is. With jumbo-sized hammering and bristling tone, these brilliant finish cymbals deliver their potent mix of clarity and cut with ear-splitting power.

LOUDEST!!!

THE CYMBALS

SPLASH

10" CC10EMS-B



CHINAS

16" CC16EMCH-B
18" CC18EMCH-B



HIHAT

14" CC14EMH-B



CRASHES

16" CC16EMC-B
17" CC17EMC-B
18" CC18EMC-B
19" CC19EMC-B



STACK

16"/18" CC16/18EMS-B



RIDE

20" CC20EMR-B



EXTREME METAL CYMBAL SET

CC-EM480
14" Hihat
18" Crash
20" Ride

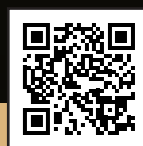

INNOVATION



When you want something totally different – something wilder than normal – step into Generation X. There are no rules. Innovation is the reason these cymbals exist. This diverse collection of designs looks and sounds creative, even crazy, but it makes perfect sense if what you want are unique sounds to create your own sonic signature.



THE CYMBALS

INNOVATION

ELECTRO STACKS

8"/10" GX-08/10ES
10"/12" GX-10/12ES

Johnny Rabb's signature cymbals



FX HATS

8" GX-8FXH
10" GX-10FXH



ATTACK STACKS

6"/8" GX-6/8AS-B
6"/10" GX-6/10AS-B

Mike Terrana's signature cymbals

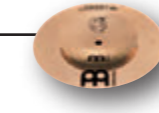

TRASH HAT

12"/14" GX-12/14TH

Benny Greb's signature cymbal



X-TREME STACK

12"/14" GX-12/14XTS



CHINA CRASHES

15" GX-15CHC-B
17" GX-17CHC-B
19" GX-19CHC-B



THOMAS LANG SIGNATURE MODELS

FILTER CHINAS

8" GX-8FCH
10" GX-10FCH
12" GX-12FCH
14" GX-14FCH
16" GX-16FCH



JOHNNY RABB SIGNATURE MODELS

DRUMBALS

8" GX-8DB
10" GX-10DB



JINGLE FILTER CHINAS

10" GX-10FCH-J
12" GX-12FCH-J
14" GX-14FCH-J



SAFARI HIHAT

12" GX-12SH



CRASHES

16" Synthetic GX-16SYC
17" Kompressor GX-17KC
18" Kinetik GX-18KC



SAFARI CRASH

16" GX-16SC



SIGNAL CRASH/KLUB RIDE

18" GX-18SC



SAFARI RIDE

18" GX-18SR



TOM'S BECKEN SETS

GX-TB14/16/18
16" Synthetik Crash
18" Signal Crash/Klub Ride

GX-TB14/17/18
17" Kompressor Crash
18" Kinetik Crash

Both sets include **FREE** 14" Filter China

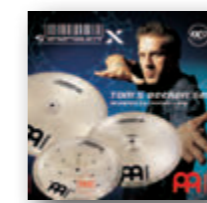

THE RABB PACK CYMBAL SET

GX-12/16/18
12" Safari Hihat
16" Safari Crash
18" Safari Ride
FREE 8" Drumbal



MIPA Winner Generation X



MCS HCS

If you're choosing your first set of real cymbals, HCS and MCS offer looks and sounds that are much more serious than their price tags suggest. Designed by the MEINL R&D team and crafted using our advanced technology, these two nicely priced series let you make your first set-up one that you can be proud of. After all, every drummer wants cymbals they feel good about, right? Take your pick – HCS in brass or MCS in bronze.

TWO METALS, TWO SOUNDS, TWO WAYS TO TAKE YOUR FIRST STEP



MCS

When what you want from your first set of cymbals are cool looks and cutting tones that sound great but won't break your bank account, MCS is a perfect choice. Precision crafted from pro-level bronze, these cymbals give you the cut you need to get your playing heard. Best of all, they let you add serious sounds to your set-up without a serious price tag.

THE CYMBALS



SPLASH
10" MCS10S



CHINA
18" MCS18CH



HIHAT
Medium
14" MCS14MH



CRASHES
Medium
14" MCS14MC
16" MCS16MC
18" MCS18MC



CRASH-RIDE
18" MCS18CR



RIDE
Medium
20" MCS20MR



BASIC CYMBAL SET
MCS1416
14" Medium Hihat
16" Medium Crash



BASIC CYMBAL SET
MCS1418
14" Medium Hihat
18" Crash-Ride



COMPLETE CYMBAL SET-UP
MCS
14" Medium Hihat
16" Medium Crash
20" Medium Ride

METAL **B8 BRONZE** SHAPING Pressure Point Technology LATHE Wide Blade FINISH Traditional SOUND Bright, Powerful STYLES Rock, Pop TO CLEAN MEINL Cymbal Cleaner



HCS

These brass alloy models look and sound great, and let you get into playing MEINL at very realistic prices. We specialize in crafting cymbals from many types of metal, which is why you can play all types of pop or rock with HCS and your sound will be warm. We believe every drummer should play cymbals they feel good about.

THE CYMBALS

SPLASHES

- 8" HCS8S
- 10" HCS10S
- 12" HCS12S



CHINAS

- 12" HCS12CH
- 14" HCS14CH
- 16" HCS16CH
- 18" HCS18CH



HIHATS

- 13" HCS13H
- 14" HCS14H



CRASHES

- 14" HCS14C
- 16" HCS16C
- 18" HCS18C



NEW!

TRASH CRASH

- 16" HCS16TRC



CRASH-RIDE

- 18" HCS18CR



RIDE

- 20" HCS20R



BASIC CYMBAL SET
HCS1416
14" Hihat
16" Crash



BASIC CYMBAL SET
HCS1418
14" Hihat
18" Crash-Ride



COMPLETE CYMBAL SET-UP
HCS141620
14" Hihat
16" Crash
20" Ride

MS63
BRASS

HAMMERING
Pressure Point Technology

LATHE
Wide Blade

FINISH
Traditional

SOUND
Mid-Bright, Warm

STYLES
Rock, Pop

TO CLEAN
MEINL Cymbal Cleaner



THE JAWBREAKER COLLECTION



LOUD AND DANGEROUS

Get the look to match the sound. From a stick bag to a stick holder, to a drum rug to a hoodie, the Jawbreaker Collection has what you need to deck out your set and yourself.

METAL



T-Shirt
 Sizes: S, M, L, XL
 Front: Jawbreaker
M85

Longsleeve
 Sizes: S, M, L, XL
 Front: Jawbreaker
M86

NEW!
Jawbreaker Hoodies
 Sizes: S, M, L, XL
M87 Hoody
M88 Hoody with Zipper

Cymbal Bag
MCB22-JB



NEW!
Percussion Table
MC-PT-JB 18" x 12"



Sling Bags
M-BAG-BK-JB Black
M-BAG-JB Red



Stick Bag
MSB-1-JB

Stick Holder
MC-DSH-JB



Practice Pads
MPP-6-JB 6"
MPP-12-JB 12"



Drum Rug
MDR-JB

CYMBAL BAGS AND CASES



NEW!
Benny Greb Artist Series Cymbal Bag
 With two external compartments, shoulder strap, a second handle, cymbal dividers and much more, Benny's 22" bag is deluxe.
MCB22-BG

Aaron Gillespie Artist Series Combo Bag
 This all-in-one '3 Pigs' combo concept: 24" cymbal bag, 15" external cymbal pocket and removable stick bag comes complete with internal cymbal dividers and strap.
MCB24/MSB-AG

Chris Adler Artist Series Cymbal Bag
 Chris Adler's 24" bag includes a 15" external compartment for hi-hats and splashes, cymbal dividers, a shoulder strap and a very cool look.
MCB24-CA

Symphonic Cymbal Bag
 An extra-deep design maximizes capacity so this is great for bigger set-ups.
 This 22" bag features two roomy external compartments.
MCB22-SY

Gig Cymbal Bag
 Ideal for casual gigs, this bag has an easy-grip handle and holds cymbals up to 22".
MSTCB22

Pro Cymbal Bags
 Ideal for gigging and touring, this bag has an external 15" compartment for splashes and hi-hats, cymbal dividers and a shoulder strap.
MCB24 Up to 24"
MCB22 Up to 22"

Pro Cymbal Backpack
 Free up your hands! This backpack design puts our 22" Professional Cymbal Bag (w/added glow-in-the dark logo for dark stages) on your back.
MCB22-BP

Designer Cymbal Bags
 This bag protects cymbals up to 22", and with a 15" external compartments it also has space for hi-hats and splashes.
MCB22-JB Jawbreaker
MCB22-C1 Camouflage

Combo Bags
 This 2-in-1 design consists of a 22" cymbal bag with a zip-off stick bag.
MCB22/MSB Black
MCB22/MSB-C1 Camouflage

Pro Cymbal Bag Trolley
 Just grab the extendable handle and go. This 22" bag rolls smoothly on a tough pair of wheels, while an extendable "foot" ensures stability when it's standing still.
MCB22-TR2

Pro Cymbal Case
 This 22" hard-shell case is designed for heavy-duty protection, with a through-case center bolt capable of securing approximately 9 cymbals.
MCC22

Pro Cymbal Case Trolley
 A retractable handle and heavy-duty wheels and a let you pull your cymbals with ease instead of lifting and carrying them.
MCC22-TR



Cymbal Dividers
 These soft dividers protect your cymbals against metal-on-metal damage in any bag or case.
MCD-22 2 x 22" pack
MCD-14 2 x 14" pack



MEINL Cymbbags
 These fabric bags protect your cymbals when not in use and let you avoid finger printing them when setting up. Sizes 6" to 24".
M-CYMBAG-6
M-CYMBAG-8
M-CYMBAG-10
M-CYMBAG-12
M-CYMBAG-13
M-CYMBAG-14
M-CYMBAG-15
M-CYMBAG-16
M-CYMBAG-17
M-CYMBAG-18
M-CYMBAG-19
M-CYMBAG-20
M-CYMBAG-21
M-CYMBAG-22
M-CYMBAG-23
M-CYMBAG-24
M-CYMB-141620
 Set consisting of 14", 16", 20"

Detachable Stick Bag

Backside of Bags

Cymbal Cases Interior

Cushioned Contact Points
 Bolted Center Rod

STILL STUFFING YOUR CYMBALS INTO ANY OLD BAG?

After all you've invested in your cymbals and putting together your own personal sound, stuffing them into any old cymbal bag just won't do. MEINL cymbal bags and hardshell cases can keep your cymbals safe everywhere – from local gigs to world tours.

Yes, keep your cymbals – and your sounds – safe. It's the smart thing to do.



STICK BAGS AND HOLDERS



Designer Stick Bags

Four spacious stick sections plus room for drum keys and small tools make this a very complete stick carrier.

MSB-1-JB Jawbreaker
MSB-1-C1 Camouflage



Chris Adler Artist Series Stick Bag

With four spacious stick pockets, an accessory compartment and the Lamb of God look, this is Chris Adler's choice.

MSB-1-CA



Pro Stick Bag

With four sections for sticks and mallets plus a compartment for small tools and other drummer delights, this padded nylon bag features an external pocket, shoulder strap and hang straps.

MSB-1



Deluxe Stick Bag

Feature-loaded with plenty of stick room, zippered clear-window pockets and two external pouches, you can carry this bag by handle or strap, and hang it on your kit with its elastic chord attachments.

MDLXSB



Drumstick Holders

So you don't miss a beat when you drop a stick, clamp this holder to your hihat or cymbal stand so you can quickly grab a stick.

MC-DSH Black
MC-DSH-JB Jawbreaker

PRACTICE PADS

Develop speed, power and precision with MEINL rapid-rebound practice pads. Carry a 6" pocket-sized pad and work on your chops anywhere. Or put a 12" on your snare drum or lock it into a snare stand, so you can warm up at gigs without driving your band crazy. Every drummer should have at least one, two or three...



NEW!
Benny Greb Artist Series Masterpad
MPP-6-BG 6"



Jawbreaker Practice Pads

MPP-6-JB 6"
MPP-12-JB 12"



Thomas Lang Artist Series Practice Pads

MPP-6-TL 6"
MPP-12-TL 12"



MEINL Practice Pads

MPP-6 6"
MPP-12 12"

DRUM RUGS



Oriental NEW!
MDR-OR

Jawbreaker
MDR-JB

Camouflage
MDR-C1

Zebra
MDR-ZB

Black
MDR-BK



So many drummers told us about their drum kits creeping on stage, we decided to do something about it. Now they're sinking their bass drum spurs into a MEINL Drum Rug. With its no-slip rubber bottom, tightly woven fabric top and great choice of graphics, it is the ultimate rug for preventing drum creep...and giving your set-up a more personalized vibe. When the gig is over, roll it up, put it in its very own bag and away you go. Never suffer from drum creep again!
160cm (5.25') x 200cm (6.50')

Quick-Set Markers

To position your drums and hardware in their correct places every time, simply mark those places on your drum rug with Quick-Set Markers hook 'n' loop strips and circles.

60 strips for hardware
10 circles for drums

MQSM

DRUM GEAR



Cymbal Stackers

Double up the cymbals on any one of your stands with a short or long stacker.

MC-CYS 6 mm thread, long version
MC-CYS8 8 mm thread, long version
MC-CYS8-S 8 mm thread, short version

Cymbal Attachment

Add another cymbal to your set-up with this multi-clamp and boom-arm combo.

MCA

Cymbal Holder

Instead of getting another cymbal stand, use this arm with a MEINL Multi Clamp (not included) to add a cymbal or percussion piece to your kit.

MC-CY



Cymbal Cleaner

This premium spray is ideal for cleaning Brilliant and Traditional finish cymbals. Simply spray on and wipe off to restore their original look.

MCCL

Cymbal Polish

Created exclusively for Brilliant finish cymbals, this concentrated liquid cleans and polishes in one simple spray-and-wipe procedure.

MCP



Multi Clamp, One Mount

Length is adjustable

With this length-adjustable clamp and rod you can position a timbale, cowbell, block or mountable tambourine anywhere within your set-up.

Includes straight rod

MC-1

Attaches to any cymbal stand



NEW! Gig Towel

If you play hard, chances are you need one of these to keep your hands dry.

MEI-HANDTUCH2



Drummer Gloves

Want a better grip so you avoid stick slip and blisters? Available with or without fingers.

MDG M, L, XL
MDGFL Fingerless M, L, XL

Tour Trolley NEW!

Ideal for clothes, or small percussion items. Fits in airplane overhead bins.

T-PBT-BK



NEW! Jawbreaker Percussion Table

Great for holding on-stage accessories.

MC-PT-JB 18" x 12"

THREE NEW DESIGNS

We are always developing different ideas and new designs, not only for cymbals, but also for sounds, gear and other items we feel will give drummers what they need to play and sound better.

Laptop Table

We have seen so many drummers using chairs and drum cases as tables for their laptops. We've also seen so many of those laptops fall to the floor. So we designed the Laptop Table. Featuring everything you need to keep your computer strapped down so it won't fall, it also keeps cables organized, keeps the computer cool and is height adjustable.

TMLTS

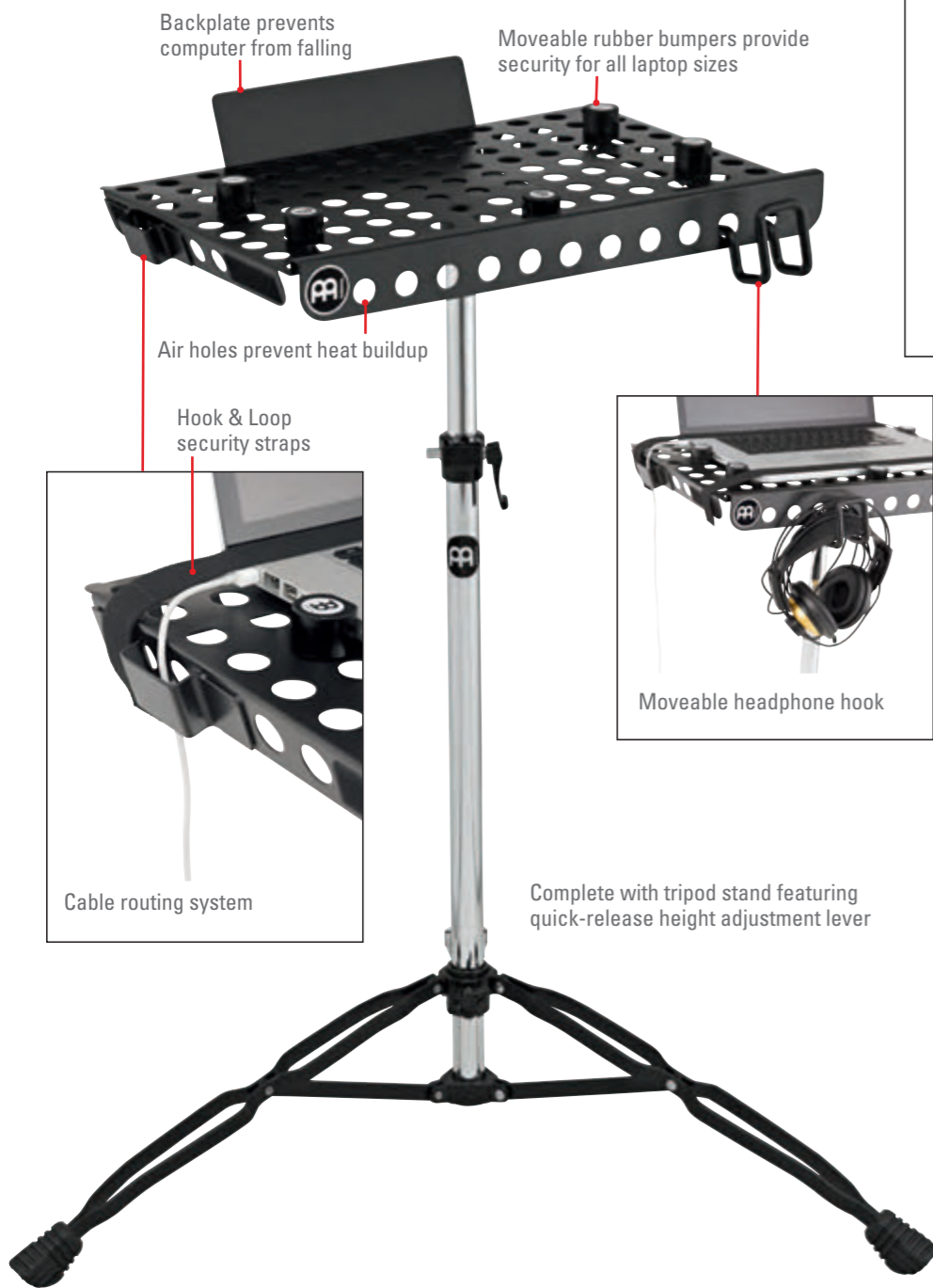

This features a two-piece metal crasher for rapid, white noise accents and a grooved design so you can play güiro rhythms. The Turbo Crasher is one of those rare percussion pieces you can play in different ways to create some very interesting effects.

CRASHER

Turbo Crasher

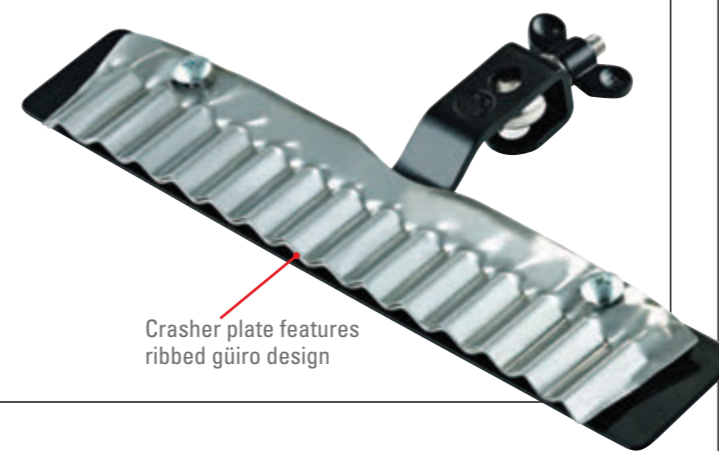

E-Drum Rug

If you play an electronic drum kit, then you know the challenge of cable management and keeping everything organized on the floor. With the new E-Drum Rug it's now possible to take control of those cables, plus ensure the rest of your kit and its pedals are securely set in place and will not move. Quick-Set Markers and transportation bag included.

150cm (4.9') x 160cm (5.25')

MDR-E



COWBELLS

A cowbell is one necessary piece of metal. Cool and cutting, it defines any groove, from rock, metal or funk, to soul, salsa and every latin style. Crafted from seriously strong steel, some sound big, metallic and wide-open, others funky, dark and dry. Clamp one onto your bass drum, cymbal stand or timbales. Cowbells fit anywhere.



Russ Miller Artist Series Cowbell

The ultimate in cowbell versatility. An innovative adjustable interior dampening device lets you control the amount of sound it puts out.

RM80B 8" Big Mouth



Dampening device



Kenny Aronoff Artist Series Cowbells

Tough and versatile, these hammered chrome models deliver with cutting power.

KA80S 8" Small Mouth
KA625 6 1/4"

Hammered Cowbells

With a strong, direct tone, this model comes in a choice of three metallic colors.

STB80BHH-C 8" Copper Big Mouth
STB80BHH-G 8" Gold Big Mouth
STB80BHH-S 8" Steel Big Mouth

Black Finish Cowbell

Sounding darker than the rest, this model punches through with a firm, dry response.

SL850-BK 8 1/2" Black Powder-Coated

Chrome Finish Cowbells

With its polished chrome finish, these cowbells look and sound bright.

STB80B-CH 8" Chrome Big Mouth
STB80S-CH 8" Chrome Small Mouth

Steel Finish Cowbells

Looking more industrial than their Chrome Finish twins, these deliver solid, punchy output in any music.

STB80B 8" Brushed Steel Big Mouth
STB80S 8" Brushed Steel Small Mouth

Headliner® Series Cowbell

A more affordable cowbell option. With a sharp, penetrating sound, this is ideal for music where volume and power come into play.

HCO2BK 8" Black Powder-Coated

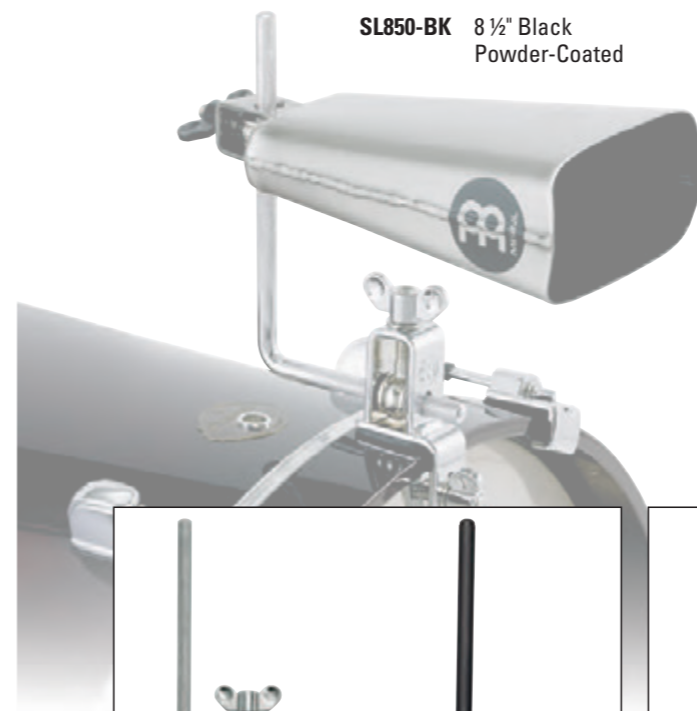

Cowbell Bass Drum Holders

Mount your cowbell in the classic position – on the bass drum hoop.

MC-BD Chrome
MC-STBD Black Powder-Coated

Pedal Mount

Attach a cowbell, block or tambourine to this height-adjustable unit, clamp a bass drum pedal to it and play.

PM-1 Black Powder-Coated, Includes two sizes of L-Rods

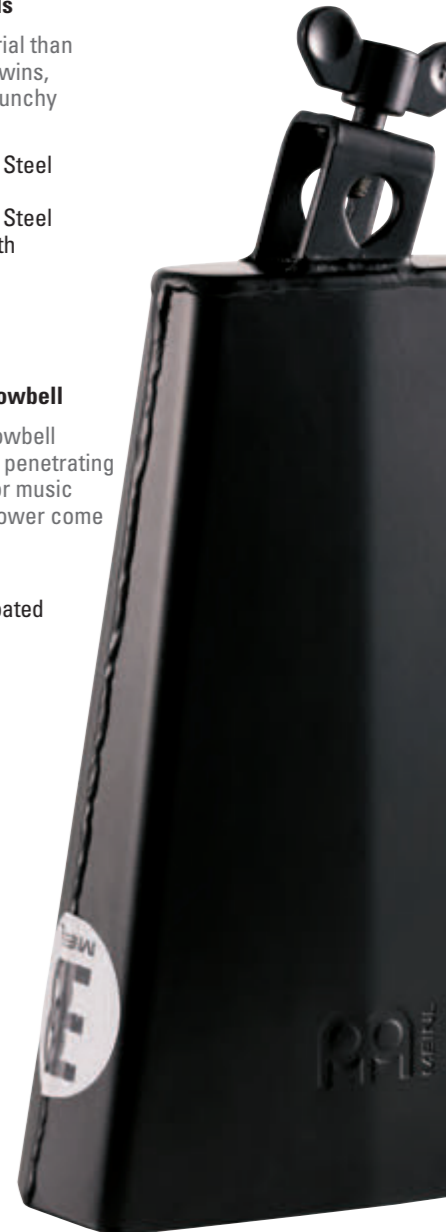

For the complete MEINL percussion selection, see our latest percussion catalog or visit: www.meinlpercussion.com

TIMBALES AND...

With their metallic shells, MEINL timbales deliver bright, penetrating responses that rip through any music, from latin to hard rock. Capable of delivering colorful and strong accents, even the smallest timbale adds a fresh element of color to a drum kit. With one or two set next to your hihat – maybe with a cowbell and tambourine to round it all out – it is possible to transform your sound and your playing with just the flick of your sticks.



Drummer Timbale
MDT13CH 13"

Drummer Mini Timbales
MIT810CH 8" + 10"

Dave Mackintosh Artist Series Attack Timbales
MDT88BN 8" x 9"
8" x 11"



Drummer Snare Timbales
Fitted with snare wires you flick on or off for a choice of two sounds.
MDST8BK 8"
MDST10BK 10"

For the complete MEINL percussion selection, see our latest percussion catalog or visit: www.meinlpercussion.com

Percussion Blocks

- MPE1BK High Pitch (Black)
- MPE2R Low Pitch (Red)



TAMBOURINES

THH1BK
1 row, steel jingles

THH1B-BK
1 row, brass jingles

HTHH1BK
1 row, steel jingles

HTHH2BK
2 rows, steel jingles

HTHH1B-BK NEW!
1 row, hammered brass jingles

HTHH2B-BK NEW!
2 rows, hammered brass jingles

Headliner® Series Hihat Tambourines

Professional Series Hihat Tambourines
Rubberized striking ring

TMT2BK
Black ABS, nickel/silver-plated steel jingles

TMT2R
Red ABS, nickel/silver-plated steel jingles

TMT2A-B
Blue ABS, aluminum jingles

TMT2B-BK
Black ABS, brass jingles

Super Dry ABS Studio Tambourines

Traditional ABS Tambourines

STMT2S-BK
Black ABS, hand hammered steel jingles

STMT2B-BK
Black ABS, hand hammered brass jingles

Easy Mountable ABS Tambourines
Tough enough to handle the heaviest hitting and featuring a güiro-style playing surface, our ABS tambourines mount on a rod or stand, with jingle variations ranging from dry and cutting, to soft and sweet.

Recording-Combo ABS Tambourine
TMT2M-WH
White ABS, steel/solid brass jingles

Hihat Tambourines

These 5" models add another element of sound and rhythm to your playing every time you pedal your hihat or play them with your sticks.



MEINL. MORE THAN JUST CYMBALS.



Symphonic and Marching Cymbals Catalog

The symphonic orchestra originated in Europe, and marching music has been central to European culture for over two thousand years. So when it comes to cymbals, isn't it logical that they be handcrafted by European artisans? With MEINL you will find traditional hand hammered cymbals, richly responsive tam tams, professional and student marching cymbals, triangles, tambourines and everything else for symphonic and marching needs.

www.meinlcymbals.com

Along with drumset cymbals, our greatest passions are symphonic cymbals and percussion. So we offer the world's largest selection of percussion pieces – from shakers and tambourines, to djembes, cajons and just about every other instrument you can shake, stroke or strike, as well as a premium selection of instruments for orchestras and marching bands.



Percussion Catalog

When they're not searching for inspiration in some far corner of the world, the MEINL R&D team is busy creating new pieces for what has become the world's largest catalog of percussion instruments. To learn more about our award-winning designs, critically acclaimed quality and comprehensive selection of modern and traditional instruments, see the MEINL Percussion Catalog or visit the MEINL Percussion website.

www.meinlpercussion.com

MERCHANDISE

THE PUMA COLLECTION



Hood Shirt by PUMA

A slim-fit cut, zip front and lace-up hood, make this an exceptional hoody.

Sizes: S, M, L, XL, XXL

M48P

T-Shirt by PUMA

Great for the gig or anywhere else, for that matter.

Sizes: S, M, L, XL, XXL

M42P

Training Jacket by PUMA

With its form-fitting cut, full-length zipper and MEINL and Puma logos right up front, this is an extremely nice jacket.

Sizes: S, M, L, XL, XXL

M71P

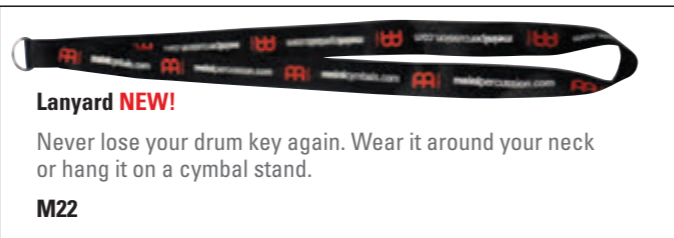

Lanyard **NEW!**

Never lose your drum key again. Wear it around your neck or hang it on a cymbal stand.

M22

T-Shirt

The classic MEINL T-shirt. It's black with our red logo. That's all. People tell us it's perfect.

Sizes: S, M, L, XL, XXL
Back: Big MEINL logo

M42



Polo Shirt

When a t-shirt is too casual, slip on one of these.

Sizes: S, M, L, XL, XXL

M25



Polo Shirt by PUMA

A classic piece. But for us, Puma added a funky little design on the back. People like to guess what it is.

Sizes: S, M, L, XL, XXL

M28P



Army Caps

Players and drum techs love this cap. Pick a color...or choose both.

M20 Black

M21 Olive



Jawbreaker T-Shirts

Short or long sleeve with Jawbreaker looming large, these are two very cool shirts.

Sizes: S, M, L, XL

M86 Longsleeve

M85 T-Shirt



NEW!

Jawbreaker Hoodies

At last – Jawbreaker on a hoody! Choose with or without zip.

Sizes: S, M, L, XL

M87 Hood Shirt

M88 Hood Shirt with Zipper



Hood Shirt with Zipper

A zip front, lace-up hood, slash pockets...it's black and has our red logo. The best things in life can be as simple as that.

Sizes: S, M, L, XL, XXL
Back: Big MEINL logo

M48



Jawbreaker Sling Bags

Sling one of these over your shoulder and carry anything from sheet music to a computer.

M-BAG-BK-JB Black

M-BAG-JB Red



Training Jacket

With its sporty look, this zip-front jacket is great for the gig, going out, or taking on tour.

Sizes: S, M, L, XL, XXL
Back: Big MEINL logo

M73

THE **NEW** meinlcymbals.com



- See all the latest MEINL news, blogs, Facebook postings, Twitter tweets and video updates in a single stream
- Check into the Cymbal Finder and Cymbal Set-up Configurator to find the cymbals you want and design your own set-up
- Check out your favourite MEINL artists
- Watch videos of top players in action
- Get the latest news from the world of MEINL including new releases, events such as the MEINL Drum Festival, artist clinics and much more
- Learn more than you already know with Tips & Tricks
- Reach out and connect with us and the rest of the MEINL world

Join us online...the world of MEINL is getting bigger every day and we welcome you to become a part of it.

CYMBAL FINDER

With Cymbalfinder, an innovative filter lets you find cymbals according to model type, weight, size, music style, sound pitch, weight, price and more... Simply select what you want and all relevant models will appear. Cymbalfinder makes your search fast, easy and accurate.

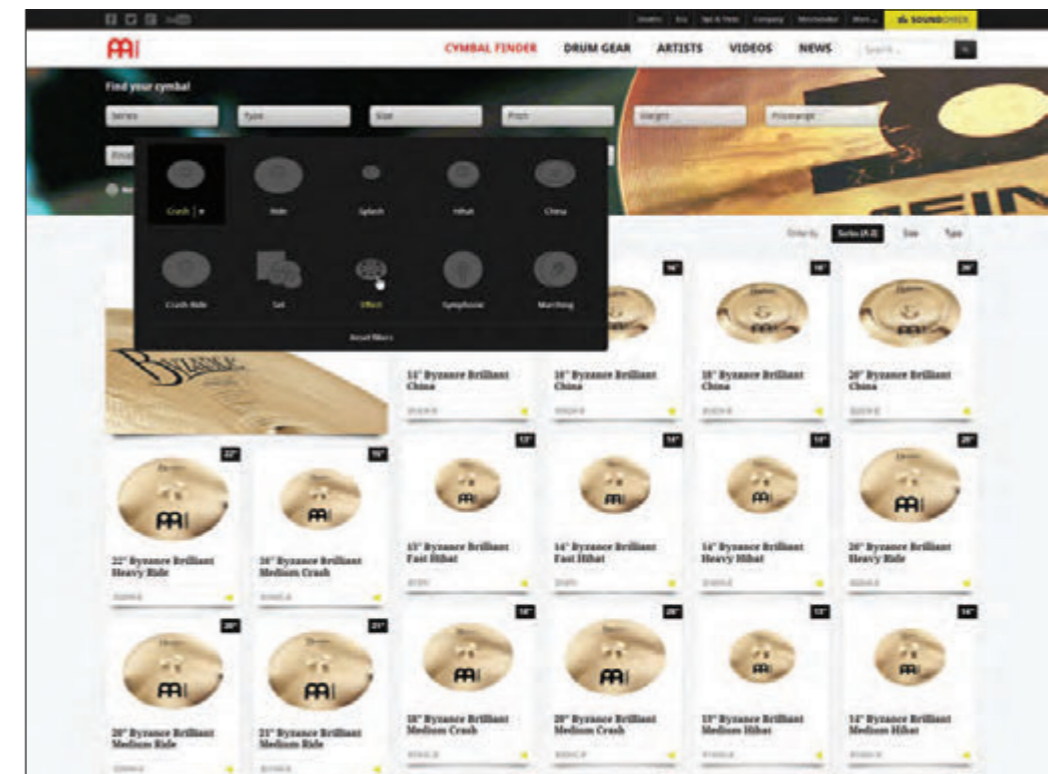

CYMBAL SET-UP CONFIGURATOR

Now you can create your own dream set-up. Pick the cymbals, pull them in the places you want, then test and compare them. Move them. Replace them with others until you get what you want. Then you can save and share that set-up with friends. Play it to them on your phone...anytime, anywhere. Your dream set-up is all yours. And if you change your mind, then change the set-up. It's as easy as that.

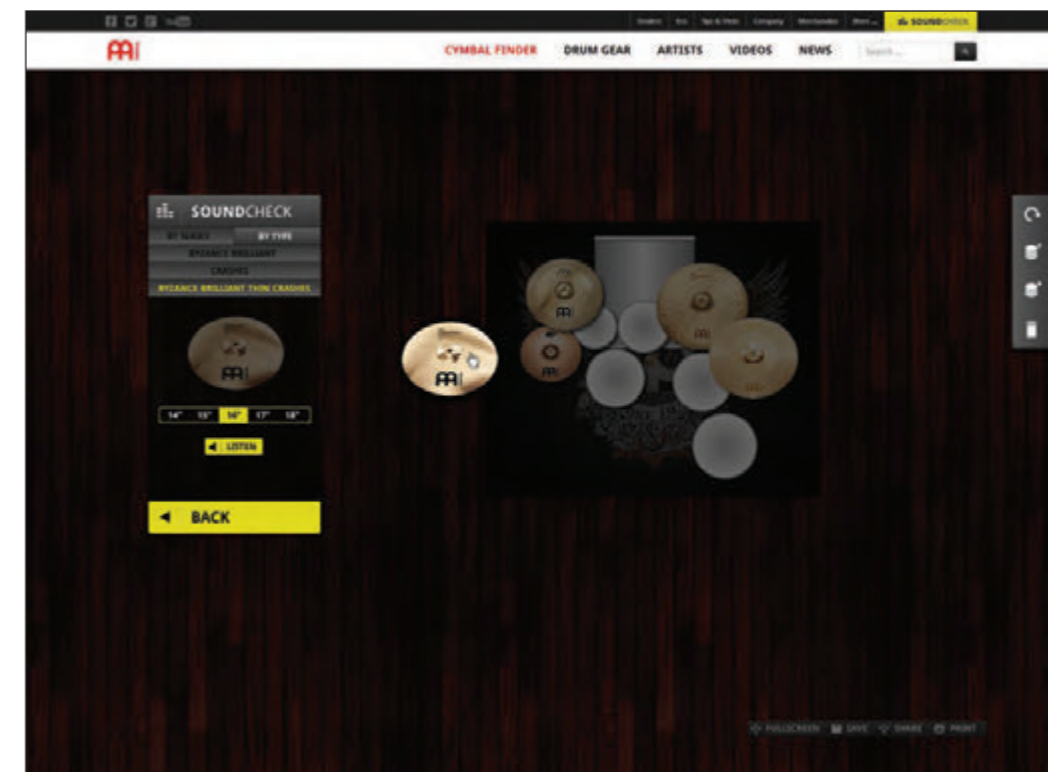

THE MEINL ONLINE NETWORK

Check out what's up with us on our new website,
or join MEINL friends and artists on our official social media communities.

Here's what's happening in the MEINL world:

- Latest new cymbal and gear news •
- MEINL Team members blog and tweet about what's happening •
- Behind the scene event reports, performance and gear photos •
 - Latest MEINL artist news and tour info •
 - Connect with others to talk about cymbals •

You can also:

Watch the latest exclusive interviews, drum lessons and performance videos of your favourite MEINL artists exclusively on your YouTube channel
...and much, much more.



meinlcymbals.com



facebook.com/meinlcymbalsfanpage



twitter.com/meinlcymbals



youtube.com/meinlcymbals



gplus.to/meinlcymbals

Thank you for interest in MEINL cymbals. If you require more information,
please visit our website or contact us directly.



Roland Meinl Musikinstrumente GmbH & Co. KG
Musik-Meinel-Str. 1
D-91468 Gutenstetten
Germany

Email: info@meinlcymbals.com



P

