

contents

- 1** MEINL Online
- 2** WHAT'S **NEW!**
- 4** The Artist Concept Models
- 8** Six Degrees of Darkness
 - 10 Byzance Traditional
 - 12 Byzance Vintage
 - 14 Byzance Jazz
 - 16 Byzance Extra Dry
 - 18 Byzance Dark
 - 20 Byzance Brilliant
- 22** Pure Alloy
- 24** The World of Classics
 - 26 Classics
 - 28 Classics Custom Brilliant
 - 30 Classics Custom Dark
 - 32 Classics Custom Extreme Metal
- 34** Generation X
- 36** First Step
 - 38 MCS
 - 40 HCS
- 42** Drum Gear
 - 42 Cymbal Bags
 - 44 Cymbal Cases, Drummer Gloves
 - 45 Stick Bags
 - 46 Practice Pads
 - 47 Drum Rugs
 - 48 Cymbal Tuners, Dynamic Pedal Pad
 - 49 Hardware
 - 50 Tables
 - 51 Cymbal Cleaners
- 52** Candela Percussion Cymbals
- 54** Symphonic Cymbals
- 56** Marching Cymbals

MEINL ONLINE

Thank you for interest in MEINL cymbals. If you require more information, please visit our website or contact us directly.



meinlcymbals.com



facebook.com/meinlcymbalsfanpage



youtube.com/meinlcymbals



twitter.com/meinlcymbals



instagram.com/meinlcymbals

Roland Meinl Musikinstrumente GmbH & Co. KG
Musik-Meinl-Str. 1
D-91468 Gutenstetten
Germany

Email: info@meinlcymbals.com



WHAT'S NEW?

MEINL is known for having the absolute widest selection of cymbal sounds and effects. What you see on this page adds to that ever-expanding tradition.



Pure Alloy

14", 15" Medium Hihats, 16", 18", 20" Medium Crashes, 20" and 22" Medium Rides

The new Meinl Pure Alloy cymbals are a timeless voice with an effortless touch and clean sound allowing drummers to express themselves in virtually any style. They feature a velvety wash combined with a full tonal spectrum extending through all dynamic levels. These cymbals cut with agility, always maintaining a superb stick definition and a well balanced wash.

The hihats cover all dynamics from a quick, responding staccato to slight sizzle to full bodied energy. The crashes hit you with a bold punch filled with highs, mids and lows, followed by a medium to long sustain. The rides push your sound with an upfront mix cushioned by fundamental lows along with a cutting bell.



The Artist Concept Models

The Artist Concept Models are a collection of cymbal voices. They are the product of Meinl Cymbal Artists and the Meinl R&D team to craft unique and innovative sounds that allow the artist to explore, create and forge ahead as leaders in acoustic music and in the art of drumming. Each one adds a musical note to the set-up emphasizing the artists' individuality and playing style.



Anika Nilles
DEEP HATS



Matt Garstka
FAT STACK



Luke Holland
BULLET STACK



Thomas Lang
SUPER STACK



**LOOK FOR
NEW!**

**Byzance Brilliant add-ons
Heavy Hammered 18", 20" Chinas, 20", 22" Crashes and 22" Ride**

These new heavy hammered cymbals combine musicality and volume. They are loud, completely in your face, and cut through in the loudest of music. The extra hand hammering allows for maximum projection and a more complex sound.



**Classics Custom Brilliant add-ons
12" and 16" Trash Stacks**

Made from B10 bronze, these two new trash stacks pack a loud and bright punch that is clearly heard in every style of music. The different sized cut-outs give them a unique look and a sonic trashiness, combined with a short sustain and cutting attack. Use them as an additional effect in your set-up or dig in for keeping solid time in complex rhythmic patterns.



Cymbal Tuners
Customize the tone of your cymbals with the new MEINL magnetic Cymbal Tuners (patent pending).

Drum Gear
More **NEW** Drum Gear products starting page 45.



**Classics Custom Dark add-ons
15" Dark Hihat, 22" Dark Ride**

The new Dark Hihat and Ride offer cutting sounds with a medium short sustain and a noticeably dark undertone. The 15" hihat has a wide sound spectrum with enhanced volume and stick definition. The 22" ride features a piercing bell sound along with a clear stick definition. Additional hammering is applied to all of the new Classics Custom Dark cymbals which add a trashier note to their overall sound characteristic.



HCS 12" and 18" Trash Stacks

Equipped with holes boosting trashiness and bite, these two new unique trash stacks deliver a fast and aggressive stack sound with a short sustain. Very direct and cutting. These are the perfect options for an entry level drummer looking to add a cool and great sounding stack into his or her set-up.



The Artist

NEW!

The Artist Concept Models are a collection of cymbal voices. They are the product of Meinl Cymbal Artists and the Meinl R&D team. The goal was to craft unique and innovative sounds that allowed the artist to explore, create and forge ahead as leaders in acoustic music and in the art of drumming.

Concept Models



Anika Nilles
DEEP HATS



Matt Garstka
FAT STACK



Luke Holland
BULLET STACK



Thomas Lang
SUPER STACK

NEW!
ANIKA NILLES - DEEP HATS
18"/18" AC-DEEP
With X-Hat Auxiliary Hihat Arm



"What I really like about my Deep Hats is that they have so many musical applications. They fill the sonic gap between my main hihats, and my crashes. I play them half open as a time keeper, very similar to crash-riding, however the Deep Hats sound softer and more articulated. That is something I prefer. They have the right amount of wash and trashiness, combined with a soft, dark tone. Absolutely perfect for my style of playing."

Zildjian

NEW!
MATT GARSTKA - FAT STACK

18"/16" AC-FAT

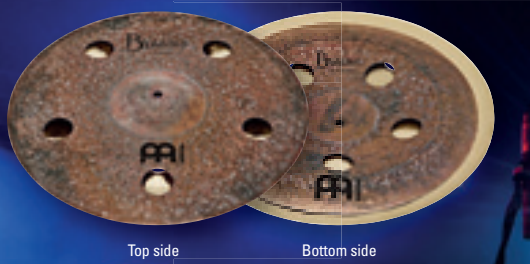

"This stack cuts through the mix with a crunchy bite. With no ring the sustain is dry and pleasing to the ear. Its trashy quality is maintained through a wide variety of tensions, with my personal favorite being a light tension that gives its Fat Stack namesake. It functions in my set-up mainly as a time keeper, but it also works extremely well with choppy accents. Coupled with a snare it has a great organic hip hop clap sound."

Matt Garstka

NEW!
LUKE HOLLAND - BULLET STACK

12"/16" AC-BULLET

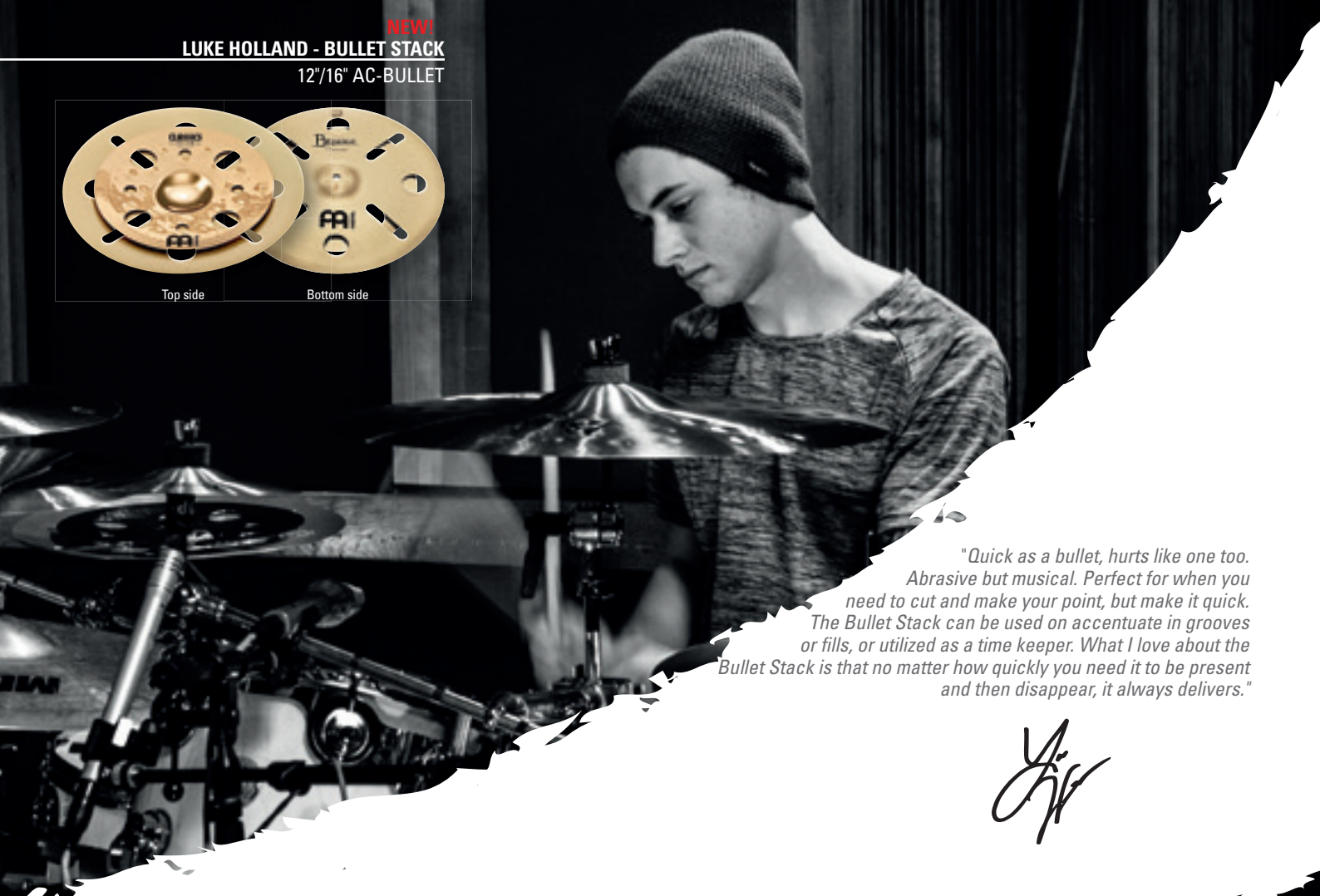

"Quick as a bullet, hurts like one too. Abrasive but musical. Perfect for when you need to cut and make your point, but make it quick. The Bullet Stack can be used on accentuate in grooves or fills, or utilized as a time keeper. What I love about the Bullet Stack is that no matter how quickly you need it to be present and then disappear, it always delivers."

"When struck at the shoulder of the top china, my Super Stack produces an aggressive mid-range bark that projects with incredible ferocity. Its fierceness cuts through any wall of sound and allows you to slice through even the most crowded soundscape. When played softly at the edge, it produces a wide and washy sizzle, perfect for accents and punctuations at a more moderate volume. When played with the stick tip at the shoulder, its short and piercing sound is reminiscent of a trashy hihat. The Super Stack is super loud, super fast, and super short. It allows the drummer to override and supersede even the most dense frequency chaos and make a clear and concise percussive statement in every musical situation. By adjusting the pressure of the wing nut, you can adjust the length of the sustain and dial up your perfect stack attack and decay. This is the most versatile stack combination you'll find."

NEW!
THOMAS LANG - SUPER STACK

18"/18" AC-SUPER



Byzance

SIX DEGREES OF DARKNESS

TRADITIONAL

VINTAGE

JAZZ



**EXTRA
DRY**

DARK

BRILLIANT



Byzance

TRADITIONAL

Dark Warmth

Their hammered and lathed surfaces, warm sounds and selection of models may be very traditional, but these cymbals are the ultimate choice when it comes to versatility. Rides with a buttery-soft feel. Crashes that range from dark and shimmering with thin models, to powerful and focused with heavier ones. Traditional tone and sonic individuality come together in each of these cymbals.



METAL

B20
BRONZE

SHAPING

Hand Hammered

LATHE

Narrow Blade

FINISH

Traditional

SOUND

Mid-Bright, Warm



SPLASHES

- 6" B6S
- 8" B8S
- 10" B10S
- 12" B12S



CHINAS

- 14" B14CH
- 16" B16CH
- 18" B18CH
- 20" B20CH
- 22" B22CH



FLAT CHINAS

- 16" B16FCH
- 18" B18FCH



MINI HAT

- 10" B10MH



HIHATS

- Thin**
- 14" B14TH
- Medium**
- 13" B13MH
 - 14" B14MH
 - 15" B15MH
 - 16" B16MH



- Heavy**
- 14" B14HH

CRASHES

- Thin**
- 14" B14TC
 - 15" B15TC
 - 16" B16TC
 - 17" B17TC
 - 18" B18TC



- Medium Thin**
- 16" B16MTC
 - 17" B17MTC
 - 18" B18MTC
 - 19" B19MTC

- Medium**
- 16" B16MC
 - 18" B18MC
 - 20" B20MC
 - 21" B21MC
 - 22" B22MC

EXTRA THIN HAMMERED CRASHES

- 18" B18ETHC
- 20" B20ETHC



RIDES

- | Medium | | Heavy | |
|--------|-------|-------|-------|
| 20" | B20MR | 20" | B20HR |
| 21" | B21MR | 21" | B21HR |
| 22" | B22MR | 22" | B22HR |
| 23" | B23MR | 23" | B23HR |
| 24" | B24MR | | |



SIZZLE RIDE

- Medium**
- 20" B20MR-S



STYLES

Rock, Pop, Fusion, Jazz, Funk, R&B, Reggae, Studio, World

TO CLEAN

MEINL Cymbal Cleaner

Byzance

VINTAGE

Dark Shimmer

The low, dark and somewhat dry washy sound of these models – most of which have a matte sandblasted finish – isn't too soft or too loud. With its great stick definition and short sustain, you can dig into Byzance Vintage for total control at all times. It has a sound that fits into any music that isn't in the upper decibel levels.



METAL

B20
BRONZE

SHAPING
Hand Hammered

LATHE
Narrow Blade

FINISH
Sandblasted

SOUND
Dark, Dry



SPLASH

10" B10VS



TRASH SPLASH

10" B10TRS



TRASH CRASHES

16" B16TRC
18" B18TRC
20" B20TRC



VINTAGE CRASHES

16" B16VC
18" B18VC
20" B20VC
22" B22VC



VINTAGE PURE HIHATS

14" B14VPH
15" B15VPH
16" B16VPH



VINTAGE PURE CRASHES

18" B18VPC
20" B20VPC



VINTAGE PURE RIDES

Vintage Pure
20" B20VPR
22" B22VPR
Vintage Pure Light
20" B20VPLR
22" B22VPLR



BENNY GREB SIGNATURE SAND MODELS

SAND HAT

14" B14SAH



SAND CRASHES

Thin
18" B18SATC
Medium
18" B18SAMC



SAND CRASH-RIDE

22" B22SACR



SAND RIDES

20" B20SAR
22" B22SAR



SAND CYMBAL SET

BV-141820SA
14" Sand Hat
18" Sand Thin Crash
20" Sand Ride

STYLES

Pop, Fusion, Jazz, Funk, R&B, Reggae, Studio, World, Electro

TO CLEAN

Not recommended

Byzance

JAZZ

Dark Tonality

Byzance Jazz. The touch and tone of these cymbals, with their soft, buttery, sink-your-stick feel and low, dark tonalities, add up to a very personalized sound. A closer look at the hammering on some models reveals large and deep dimpling that boosts dryness and darkness.



METAL

B20
BRONZE

SHAPING
Hand Hammered

LATHE
Narrow Blade

FINISH
Traditional

SOUND
Dark, Tonally Complex



TRADITION HIHAT

14" B14TRH



TRADITION CRASH

Tradition Light
18" B18TRLC



TRADITION RIDES

Tradition
20" B20TRR
22" B22TRR



Tradition Light
20" B20TRLR
22" B22TRLR

TRADITION FLAT RIDE

22" B22TRFR



NUANCE RIDE

21" B21NUR



Ralph Peterson's
signature cymbal

SYMMETRY RIDE

22" B22SYR



Ralph Peterson's
signature cymbal

CLUB RIDES

20" B20JCR
22" B22JCR



Wolfgang Haffner's
signature cymbals

SPLASH

10" B10JS



HIHATS

Thin
13" B13JTH
14" B14JTH



CRASHES

Extra Thin
16" B16JETC
17" B17JETC
18" B18JETC



Thin
16" B16JTC
17" B17JTC
18" B18JTC
20" B20JTC

Medium Thin
16" B16JMTC
17" B17JMTC
18" B18JMTC
20" B20JMTC

CHINA RIDE

22" B22JCHR



RIDES

Extra Thin
20" B20JETR
22" B22JETR



Thin
20" B20JTR
22" B22JTR

Medium Thin
20" B20JMTR
22" B22JMTR

Medium
20" B20JMR
22" B22JMR

BIG APPLE RIDES

20" B20JBAR
22" B22JBAR



FLAT RIDE

20" B20JFR

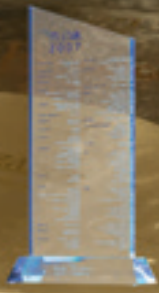

MIPA Winner
Byzance Jazz

STYLES

Jazz, Funk, Reggae, Studio, World, Electro

TO CLEAN

MEINL Cymbal Cleaner

Byzance

EXTRA DRY



METAL

SHAPING
Hand Hammered

LATHE
None

FINISH
Raw

SOUND
Dark, Extra Dry

Dark Definition

Living up to their name, these cymbals are extremely dry, with low-pitched, trashy sounds and short sustain. The raw unlathed surfaces and extensive hand hammering suggest that their sound might be loud and fierce. In reality, the Extra Dry series reveals its dark, earthy tones and comes to life when played at lower volumes.



SPLASHES

- 10" B10EDS
- 12" B12EDS



CHINAS

- 16" B16EDCH
- 18" B18EDCH
- 20" B20EDCH



HIHATS

Medium Thin

- 15" B15EDMTH
- 16" B16EDMTH

Medium

- 13" B13EDMH
- 14" B14EDMH



CRASHES

Thin

- 16" B16EDTC
- 17" B17EDTC
- 18" B18EDTC
- 19" B19EDTC
- 20" B20EDTC



RIDES

Thin

- 20" B20EDTR
- 22" B22EDTR

Medium

- 20" B20EDMR
- 22" B22EDMR



TRANSITION RIDE

- 21" B21TSR

Mike Johnston's signature cymbal



DUAL SPLASH

- 10" B10DUS



DUAL HIHAT

- 15" B15DUH



DUAL CRASHES

- 16" B16DUC
- 18" B18DUC



DUAL CRASH-RIDES

- 20" B20DUCR
- 22" B22DUCR



STYLES

Jazz, Funk, R&B, Studio, Electro

TO CLEAN

MEINL Cymbal Cleaner

Byzance

DARK



METAL

B20
BRONZE

SHAPING

Hand Hammered

LATHE

Abraded

FINISH

Dark

SOUND

Mid-Dark, Earthy

Dark Intensity

Their sound is dark, and so is their oven-blackened look. Byzance Dark models are intense, with responses ranging from the defined sticking of the rides, to the short, punchy bursts of the crashes. Their unique sonic qualities are ideal for music where dark tone and feel are at the top of the 'must have' list.



SPLASHES

- 8" B8DAS
- 10" B10DAS



CHINA

- 18" B18DACH



HIHATS

- 13" B13DAH
- 14" B14DAH
- 15" B15DAH



SPECTRUM HIHATS

- 13" B13SH
- 14" B14SH

Rodney Holmes' signature cymbals



CRASHES

- 16" B16DAC
- 17" B17DAC
- 18" B18DAC
- 20" B20DAC



RIDES

- 20" B20DAR
- 21" B21DAR
- 22" B22DAR



RAW BELL RIDES

- 20" B20RBR
- 22" B22RBR



SPECTRUM RIDE

- 22" B22SR

Rodney Holmes' signature cymbal



SKY RIDE

- 19" B19SKR

Noriaki Kumagai's signature cymbal



BIG APPLE DARK RIDES

- 20" B20BADAR
- 22" B22BADAR
- 24" B24BADAR



STYLES

Pop, Fusion, Jazz, Funk, R&B, Reggae, Studio, World, Electro

TO CLEAN

MEINL Cymbal Cleaner

Byzance

BRILLIANT



METAL

B20
BRONZE

SHAPING

Hand Hammered

LATHE

Narrow Blade

FINISH

Brilliant

SOUND

Mid-Bright, Tonally Rich

Dark Brightness

Though 'Brilliant' refers to its finish, this series actually takes the traditional Byzance and darkens its sound. This darker sound is due to a finishing process that limits the high end as the cymbal is buffed to its brilliant look. Heavier models penetrate with directness, thinner ones shimmer with warmth. The overall combination of dark tonality and warm spread make Byzance Brilliant a great choice for everything from funk and fusion to rock.

NEW!
HEAVY HAMMERED CHINAS

- 18" B18HHCH-B
- 20" B20HHCH-B



NEW!
HEAVY HAMMERED CRASHES

- 20" B20HHC-B
- 22" B22HHC-B



NEW!
HEAVY HAMMERED RIDE

- 22" B22HHR-B



PURE METAL RIDE

- 24" B24PMR-B

Chris Adler's
signature cymbal



SPLASHES

- 6" B6S-B
- 8" B8S-B
- 10" B10S-B



CHINAS

- 14" B14CH-B
- 16" B16CH-B
- 18" B18CH-B
- 20" B20CH-B



HIHATS

Medium

- 13" B13MH-B
- 14" B14MH-B



Heavy

- 14" B14HH-B

FAST HIHATS

- 13" B13FH
- 14" B14FH



Thomas Lang's
signature cymbals

SERPENTS HIHATS

- 13" B13SH-B
- 14" B14SH-B



Derek Roddy's
signature cymbals

CRASHES

Thin

- 14" B14TC-B
- 15" B15TC-B
- 16" B16TC-B
- 17" B17TC-B
- 18" B18TC-B



Medium Thin

- 16" B16MTC-B
- 17" B17MTC-B
- 18" B18MTC-B
- 19" B19MTC-B

Medium

- 16" B16MC-B
- 18" B18MC-B
- 20" B20MC-B

RIDES

Medium

- 20" B20MR-B
- 21" B21MR-B
- 22" B22MR-B
- 24" B24MR-B



Heavy

- 20" B20HR-B
- 22" B22HR-B

SERPENTS RIDE

- 21" B21SR-B

Derek Roddy's
signature cymbal



STYLES

Rock, Pop, Fusion, Funk, R&B, Reggae, Studio

TO CLEAN

MEINL Cymbal Polish

PURE ALLOY

 MADE IN GERMANY
 MEINL



METAL

PURE
 ALLOY

SHAPING

Computerized Hammering

LATHE

Pinpoint

FINISH

Traditional

SOUND

Shimmering Clarity

Shimmering Clarity

Effortless touch and clean sound. This is MEINL Pure Alloy. A timeless voice formed with fully lathed surfaces allows them to be expressive in virtually any style. Their refined nature has two sides: polished definition met by a velvety wash that encompasses a full tonal spectrum. Shimmering, smooth sounds bounce right along with your stick to create a reactive touch that extends through all dynamic levels. These cymbals cut with agility. Blanketing their superb stick definition is a sustain that plays out with just the right amount of strength and balanced wash.



NEW! HIHATS

Medium
14" PA14MH
15" PA15MH



NEW! CRASHES

Medium
16" PA16MC
18" PA18MC
20" PA20MC



NEW! RIDES

Medium
20" PA20MR
22" PA22MR



STYLES

Rock, Pop, Fusion, R&B, Reggae, Studio

TO CLEAN

MEINL Cymbal Cleaner

CLARITY AND CUT

CLASSICS

CLASSICS
—CUSTOM—
BRILLIANT SERIES



LOUD!

LOUDER!!

Loud. Louder. Loudest. From the loud Classics, to the louder Classics Custom Brilliant and Dark to the loudest, Classics Custom Extreme Metal, this quartet of innovative cymbals is all about high-energy response. These cymbals add pure punch wherever clarity and cut are a must. Ideal for pop, rock, and the most brutal metal imaginable, all four will get you heard.

CLASSICS
— CUSTOM —
DARK SERIES

CLASSICS
— CUSTOM —
EXTREME METAL SERIES



LOUDEST!!!

CLASSICS

Powered by bright, widely lathed B8 bronze, this nicely priced series is great for cutting through most volumes. With explosive crash responses and glassy ride definition, Classics models may not be as powerful as the very different Custom or Extreme Metal, but their ability to project is unquestionable.

LOUD!



METAL **B8 BRONZE** **SHAPING** Pressure Point Technology **LATHE** Wide Blade **FINISH** Traditional **SOUND** Bright, Clear



BELLS

- 8" C8BL Low
- 8" C8BM Medium
- 8" C8BH High



SPLASHES

- 8" C8S
- 10" C10S
- 12" C12S



CHINA SPLASH

- 10" C10CS



CHINAS

- 12" C12CH
- 14" C14CH
- 16" C16CH
- 18" C18CH



MINI HAT

- 10" C10MH



HIHATS

- Medium**
- 14" C14MH
- Powerful**
- 14" C14PH



SOUNDWAVE HIHATS

- Medium**
- 14" C14MSW
- Powerful**
- 14" C14PSW



CRASHES

- Thin**
- 16" C16TC
- 18" C18TC
- Medium**
- 14" C14MC
- 15" C15MC
- 16" C16MC
- 17" C17MC
- 18" C18MC
- 20" C20MC
- Powerful**
- 16" C16PC
- 17" C17PC
- 18" C18PC



RIDES

- Medium**
- 20" C20MR
- 21" C21MR
- 22" C22MR
- Powerful**
- 20" C20PR



COMPLETE CYMBAL SET

- C141620
- 14" Medium Hihat
- 16" Medium Crash
- 20" Medium Ride

CLASSICS

— CUSTOM —

BRILLIANT SERIES



METAL

B10
BRONZE

SHAPING

Pressure Point Technology

LATHE

None

FINISH

Brilliant

SOUND

Bright, Musical

LOUDER!!

Made with B10 bronze, Classics Custom Brilliant models pack a loud and bright punch that gets you heard clearly in every style of music. Designed to cut above the roar of guitars, these cymbals do most of the work for you, so you don't have to play as hard to be heard. With great stick response on the rides and hats, you can dig in and groove, while the crashes deliver powerful accents.

GHOST RIDE

21" CC21GR

Brann Dailor's signature cymbal



RIDES

Medium

20" CC20MR-B

Powerful

20" CC20PR-B

22" CC22PR-B



COMPLETE CYMBAL SET

CC141620

14" Medium Hihat
16" Medium Crash
20" Medium Ride

BELL

8" CC8B-B



SPLASHES

8" CC8S-B

10" CC10S-B

12" CC12S-B



TRASH SPLASH

12" CC12TRS-B



CHINAS

16" CC16CH-B

18" CC18CH-B



TRASH CHINAS

16" CC16TRCH-B

18" CC18TRCH-B



HIHATS

Medium

14" CC14MH-B

15" CC15MH-B

Powerful

14" CC14PH-B



CRASHES

Medium

14" CC14MC-B

15" CC15MC-B

16" CC16MC-B

17" CC17MC-B

18" CC18MC-B

Powerful

16" CC16PC-B

18" CC18PC-B



TRASH CRASHES

16" CC16TRC-B

18" CC18TRC-B



NEW!

TRASH STACKS

12" CC-12STK

16" CC-16STK



CLASSICS

— CUSTOM —

DARK SERIES



METAL

B10
BRONZE

SHAPING

Pressure Point Technology & Computersized Hammering

LATHE

Wide Blade

FINISH

Dark

SOUND

Mid-Dark, Trashy

LOUDER!!

Classics Custom Dark cymbals undergo a special finishing process that leaves the cymbals with dark and complex tones along with the clarity, cut and volume that Classics Custom is known to deliver. This same unique twist on the traditional design gives the cymbals a rich, dark appearance. Widely spaced deep hammering and additional lathing round out their tonal qualities, giving them a warmer mix of sound along with an explosive response.

DARK SPLASH

10" CC10DAS



DARK HIHATS

14" CC14DAH

15" CC15DAH **NEW!**



DARK CRASHES

16" CC16DAC

18" CC18DAC

19" CC19DAC

20" CC20DAC

21" CC21DAC



DARK CHINA

18" CC18DACH



DARK CRASH-RIDE

22" CC22DACR



DARK RIDES

20" CC20DAR

22" CC22DAR **NEW!**



DARK CYMBAL SET

CCD141620

14" Dark Hi-hat

16" Dark Crash

20" Dark Ride

STYLES

Metal, Rock, Pop, Fusion, Studio

TO CLEAN

MEINL Cymbal Cleaner

CLASSICS CUSTOM

EXTREME METAL SERIES

Brutally loud and intense, Classics Custom Extreme Metal models are totally effective when it comes to projecting through the loudest and most aggressive music there is. With jumbo-sized hammering and bristling tone, these brilliant finish cymbals deliver their potent mix of clarity and cut with ear-splitting power.

LOUDEST!!!



METAL

SHAPING

Pressure Point Technology & Computerized Hammering

LATHE

None

FINISH

Brilliant

SOUND

Bright, Penetrating



SPLASH

10" CC10EMS-B



CHINAS

16" CC16EMCH-B
18" CC18EMCH-B



HIHAT

14" CC14EMH-B



CRASHES

16" CC16EMC-B
17" CC17EMC-B
18" CC18EMC-B
19" CC19EMC-B



STACK

16"/18" CC16/18EMS-B



RIDE

20" CC20EMR-B



EXTREME METAL CYMBAL SET

CC-EM480
14" Hihat
18" Crash
20" Ride

STYLES

Metal, Rock, Pop, Fusion, Studio

TO CLEAN

MEINL Cymbal Cleaner



When you want something totally different – something wilder than normal – step into Generation X. There are no rules. Innovation is the reason these cymbals exist. This diverse collection of designs looks and sounds creative, even crazy, but it makes perfect sense if what you want are unique sounds to create your own sonic signature.

INNOVATION



METAL
Varies

SHAPING
Pressure Point Technology &
Computerized Hammering

LATHE
Varies

FINISH
Varies

SOUND
Mid-Bright, Experimental

DESIGN



IDEAS



MIPA Winner
Generation X

FX HATS

- 8" GX-8FXH
- 10" GX-10FXH



TRASH HAT

- 12"/14" GX-12/14TH

Benny Greb's
signature cymbal



X-TREME STACK

- 12"/14" GX-12/14XTS



CHINA CRASHES

- 15" GX-15CHC-B
- 17" GX-17CHC-B
- 19" GX-19CHC-B



JOHNNY RABB SIGNATURE MODELS

DRUMBALS

- 8" GX-8DB
- 10" GX-10DB



ELECTRO STACKS

- 8"/10" GX-08/10ES
- 10"/12" GX-10/12ES



THOMAS LANG SIGNATURE MODELS

FILTER CHINAS

- 8" GX-8FCH
- 10" GX-10FCH
- 12" GX-12FCH
- 14" GX-14FCH
- 16" GX-16FCH



JINGLE FILTER CHINAS

- 10" GX-10FCH-J
- 12" GX-12FCH-J
- 14" GX-14FCH-J



STYLES

Rock, Pop, Fusion, R&B, Reggae, Studio, World, Electro

TO CLEAN

MEINL Cymbal Cleaner

MCS HCS



B8
BRONZE



If you're choosing your first set of real cymbals, HCS and MCS offer looks and sounds that are much more serious than their price tags suggest. Designed by the MEINL R&D team and crafted using our advanced technology, these two nicely priced series let you make your first set-up one that you can be proud of. After all, every drummer wants cymbals they feel good about, right? Take your pick – HCS in brass or MCS in bronze.

TWO METALS, TWO SOUNDS, TWO WAYS TO TAKE YOUR FIRST STEP



MS63
BRASS

MCS

When what you want from your first set of cymbals are cool looks and cutting tones that sound great but won't break your bank account, MCS is a perfect choice. Precision crafted from pro-level bronze, these cymbals give you the cut you need to get your playing heard. Best of all, they let you add serious sounds to your set-up without a serious price tag.



METAL

B8
BRONZE

SHAPING

Pressure Point Technology

LATHE

Wide Blade

FINISH

Traditional

SOUND

Bright, Powerful

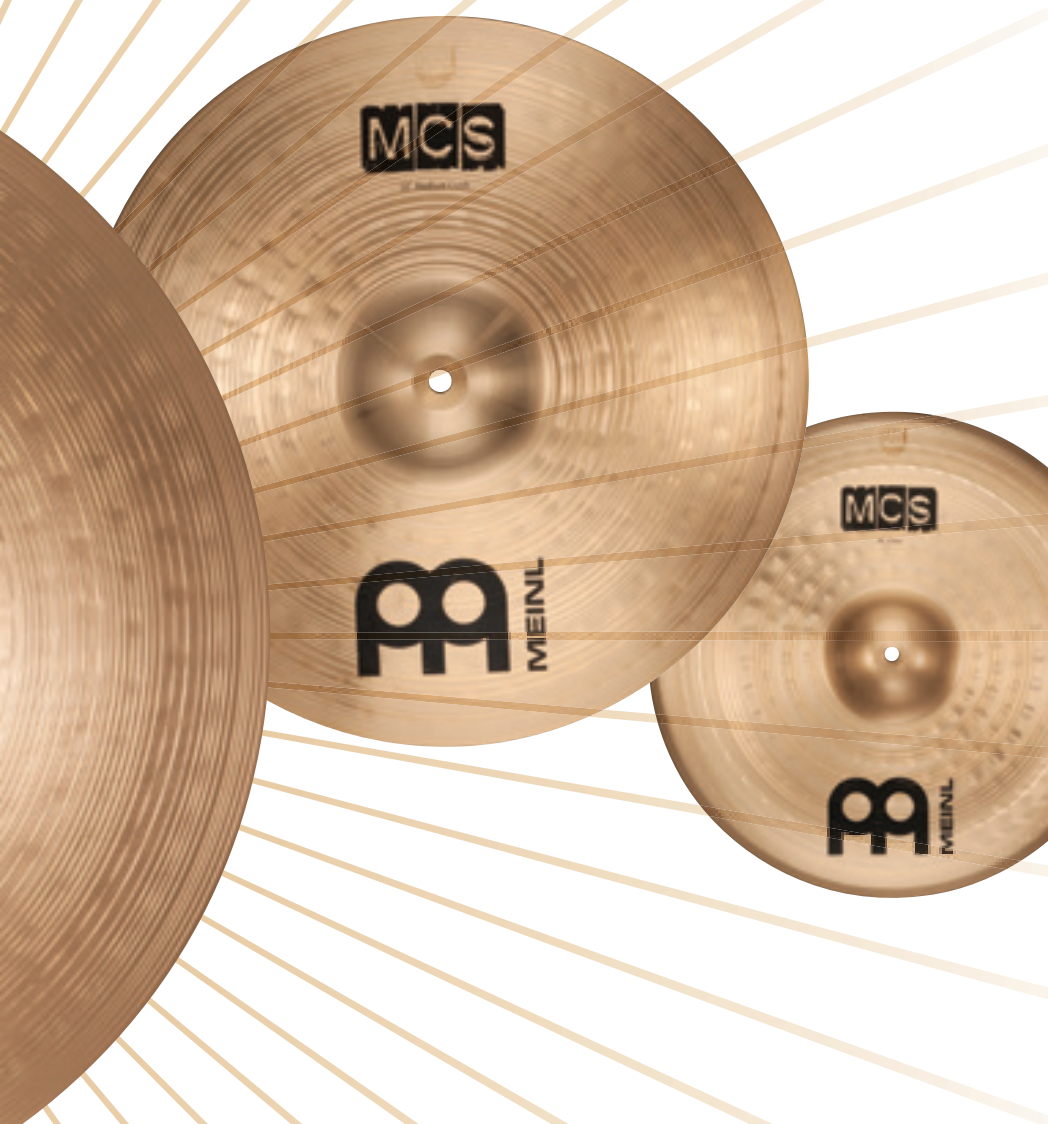

SPLASH

10" MCS10S



CHINA

18" MCS18CH



HIHAT

Medium
14" MCS14MH



CRASHES

Medium
14" MCS14MC
16" MCS16MC
18" MCS18MC



CRASH-RIDE

18" MCS18CR



RIDE

Medium
20" MCS20MR



COMPLETE CYMBAL SET

MCS
14" Medium Hi-hat
16" Medium Crash
20" Medium Ride

HCS

These brass alloy models look and sound great, and let you get into playing MEINL at very realistic prices. We specialize in crafting cymbals from many types of metal, which is why you can play all types of pop or rock with HCS and your sound will be warm. We believe every drummer should play cymbals they feel good about.



MS63
BRASS

HAMMERING
Pressure Point Technology

LATHE
Wide Blade

FINISH
Traditional

SOUND
Mid-Bright, Warm



BASIC CYMBAL SET

HCS1416
14" Hihat
16" Crash



BASIC CYMBAL SET

HCS1418
14" Hihat
18" Crash-Ride



COMPLETE CYMBAL SET

HCS141620
14" Hihat
16" Crash
20" Ride

BELL

8" HCS8B



SPLASHES

8" HCS8S
10" HCS10S
12" HCS12S



TRASH CRASH

16" HCS16TRC



TRASH STACKS

12" HCS12TRS **NEW!**
14" HCS14TRS
16" HCS16TRS
18" HCS18TRS **NEW!**



CHINAS

12" HCS12CH
14" HCS14CH
16" HCS16CH
18" HCS18CH



HIHATS

13" HCS13H
14" HCS14H



CRASHES

14" HCS14C
16" HCS16C
18" HCS18C
20" HCS20C



CRASH-RIDE

18" HCS18CR



RIDE

20" HCS20R



CYMBAL BAGS

After all you've invested in your cymbals and putting together your own personal sound, stuffing them into any old cymbal bag just won't do. MEINL cymbal bags and hardshell cases can keep your cymbals safe everywhere – from local gigs to world tours.



Designer Cymbal Bag

This bag protects cymbals up to 22", and with a 15" external compartment it also has space for hihats and splashes.

MCB22-JB

Symphonic Cymbal Bag

An extra-deep design maximizes capacity so this is great for bigger set-ups.

This 22" bag features two roomy external compartments.

MCB22-SY

Benny Greb Artist Series Cymbal Bag

With two external compartments, shoulder strap, a second handle, cymbal dividers and much more, Benny's 22" bag is deluxe.

MCB22-BG

Yes, keep your cymbals – and your sounds – safe. It's the smart thing to do.

CYMBAL BAGS



Pro Cymbal Bag

The 16" Cymbal Bag has a small external pocket for drum gear. It comes with a divider to protect the cymbals and includes a shoulder strap.

MCB16



Gig Cymbal Bag

Ideal for casual gigs, this bag has an easy-grip handle and holds cymbals up to 22".

MSTCB22



Pro Cymbal Bags

Ideal for gigging and touring, this bag has an external 15" compartment for splashes and hihats, cymbal dividers and a shoulder strap.

MCB22 up to 22"

MCB24 up to 24"



Pro Cymbal Backpack

Free up your hands! This backpack design puts our 22" Professional Cymbal Bag (w/added glow-in-the dark logo for dark stages) on your back.

MCB22-BP

CYMBAL CASES, DRUMMER GLOVES



Cymbal Cases Interior

Cushioned Contact Points

Bolted Center Rod

Pro Cymbal Case Trolley

A retractable handle and heavy-duty wheels let you pull your cymbals with ease instead of lifting and carrying them.

MCC22-TR

Pro Cymbal Case

This 22" hard-shell case is designed for heavy-duty protection, with a through-case center bolt capable of securing approximately 9 cymbals.

MCC22



Cymbal Dividers

These soft dividers protect your cymbals against metal-on-metal damage in any bag or case.

MCD-14 2pc 14" pack

MCD-22 2pc 22" pack



Drummer Gloves

Want a better grip so you avoid stick slip and blisters? Available with or without fingers.

MDG M, L, XL

MDGFL Fingerless M, L, XL

STICK BAGS



Pro Stick Bag

With four sections for sticks and mallets plus a compartment for small tools and other drummer delights, these two padded nylon bags feature an external pocket, shoulder strap and hang straps.

MSB-1 Black

MSB-2 The Horns **NEW!**



Compact Stick Bag

The smaller brother of our Pro Stick Bag offers two sections for four pairs of sticks or mallets. The slim sized bag is perfect for being on the go and saving space.

MCSB



Designer Stick Bags

Four spacious stick sections plus room for drum keys and small tools make this a very complete stick carrier.

MSB-1-JB Jawbreaker

MSB-1-C1 Camouflage



Chris Adler Artist Series Stick Bag

With four spacious stick pockets, an accessory compartment and the Lamb of God look, this is Chris Adler's choice.

MSB-1-CA



Deluxe Stick Bag

Feature-loaded with plenty of stick room, zippered clear-window pockets and two external pouches, you can carry this bag by handle or strap, and hang it on your kit with its elastic chord attachments.

MDLXSB

PRACTICE PADS

Develop speed, power and precision with MEINL rapid-rebound practice pads. Carry a 6" pocket-sized pad and work on your chops anywhere. Or put a 12" on your snare drum or lock it into a snare stand, so you can warm up at gigs without driving your band crazy. Every drummer should have at least one, two or three...



Benny Greb
Artist Series Masterpads
MPP-6-BG 6"
MPP-12-BG 12"



Thomas Lang
Artist Series Practice Pads
MPP-6-TL 6"
MPP-12-TL 12"



Jawbreaker Practice Pads
MPP-6-JB 6"
MPP-12-JB 12"



MEINL Practice Pads
MPP-6 6"
MPP-12 12"



NEW!
Knee Pad Mount

The Knee Pad Mount is a genius tool for every drummer to practice everywhere. It allows you to strap most any threaded (8mm) practice pad to your knee.

MKPM Designed in cooperation with Benny Greb



Adjustable strap to secure in place



Adjustable strap to secure in place

4" Knee Pad

Develop speed, power and precision - anytime and anywhere - with the 4" Knee Pad. With a compact size and light weight, it comfortably sits on your knee and can be secured with the adjustable strap. It's the perfect way for drummers to practice on the go!

MKPP-4



DRUM RUGS

The MEINL Drum Rug is the ultimate for preventing drum creep. With its no-slip rubber bottom, tightly woven fabric top and great choice of graphics giving your set-up a more personalized vibe, it lets you sink your bass drum spurs and feel secure. And when the gig is over, roll it up, put it in its very own bag and away you go. 160cm (5.25') x 200cm (6.50')

**Oriental
MDR-OR**

**Jawbreaker
MDR-JB**

**Camouflage
MDR-C1**

**Zebra
MDR-ZB**

**Black
MDR-BK**



Quick-Set Markers

To position your drums and hardware in their correct places every time, simply mark those places on your drum rug with Quick-Set Markers hook 'n' loop strips and circles.

60 strips for hardware
10 circles for drums

MQSM

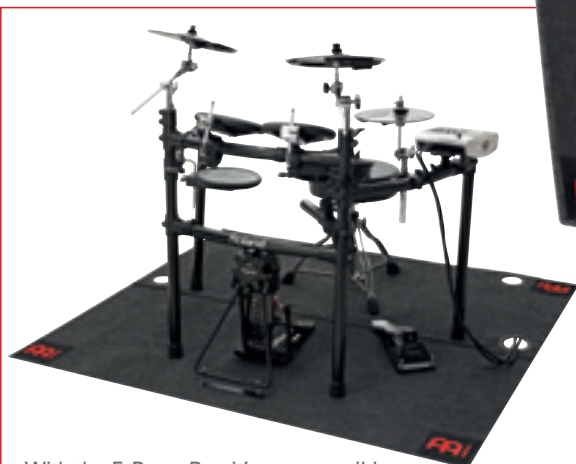

With the E-Drum Rug it's now possible to manage cables, plus ensure the rest of your kit and its pedals are securely set in place and will not move.

E-Drum Rug

Quick-Set Markers and transportation bag included. 150cm (4.9') x 160cm (5.25')

MDR-E

DRUM GEAR



NEW!

Cymbal Tuners (patent pending)

The MEINL magnetic Cymbal Tuners offer an easy way to tweak the sound of your cymbals. Simply place the magnets on the cymbal (mated up top and bottom). By positioning the Cymbal Tuners in different spots on the surface, you can control the sustain, dampen the tone, adjust the volume, and optimize the sound of your cymbal to just the way you like it.

MCT

2pc 16x4mm - light damping
2pc 16x9mm - heavy damping
With storage barrel

Designed in cooperation with
Benny Greb

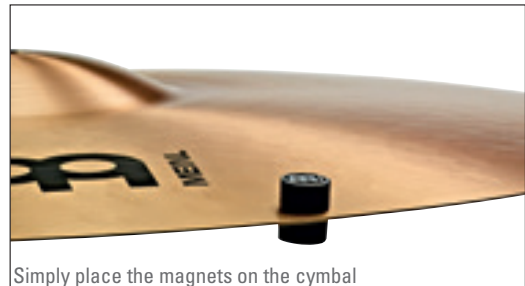

Simply place the magnets on the cymbal



Ching Ring

Incorporate a "ching" into your backbeats by placing the Ching Ring directly on your cymbals! Ideal for hihats, these steel jingles will add a different touch to your playing by delivering a shimmering sound that will blend perfectly with your beats. Place the Ching Ring on crashes and rides as well for some truly innovative sounds.

CRING



Usable with any bass drum pedal



NEW!

Dynamic Pedal Pad

Advanced Bass Drum Pedal Practice Pad for Single or Double Kick that responds at any dynamic level. Whereas most bass drum practice pads are designed with only speed in mind - the Dynamic Pedal Pad goes deeper. It helps you develop control, independence and feel in addition to speed along with the dynamic response needed so you can clearly hear every note at any volume from very soft to very loud.

MDPP

Designed in cooperation with
Benny Greb

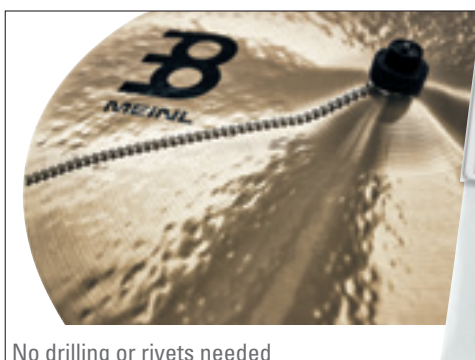

No drilling or rivets needed



Cymbal Bacon

Simply place the chain on top of your cymbal and make it sizzle. No drilling or permanent rivets needed. Easy to use on any cymbal stand.

BACON

DRUM GEAR

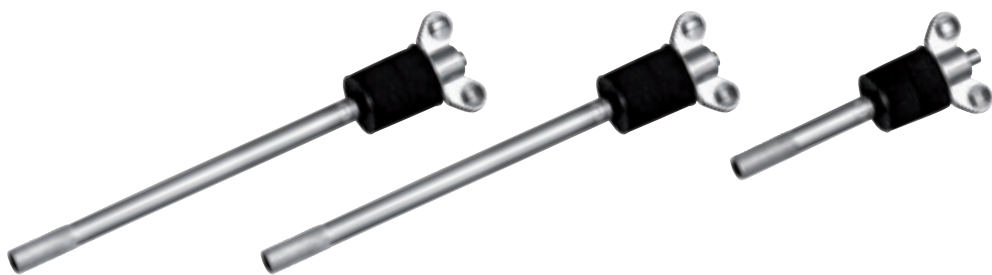

Cymbal Stackers

Double up the cymbals on any one of your stands with a short or long stacker.

- MC-CYS** 6 mm thread, long version
- MC-CYS8** 8 mm thread, long version
- MC-CYS8-S** 8 mm thread, short version

Cymbal Attachment

Add another cymbal to your set-up with this multi-clamp and boom-arm combo.

MCA



Multi Clamp, One Mount

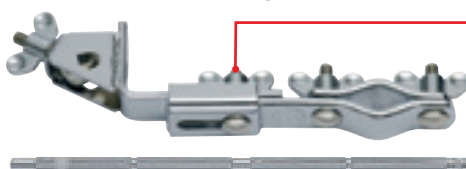

Length is adjustable

With this length-adjustable clamp and rod you can position a timbale, cowbell, block or mountable tambourine anywhere within your set-up.

Includes straight rod

MC-1

Cymbal Holder

Instead of getting another cymbal stand, use this arm with a MEINL Multi Clamp (not included) to add a cymbal or percussion piece to your kit.

MC-CY

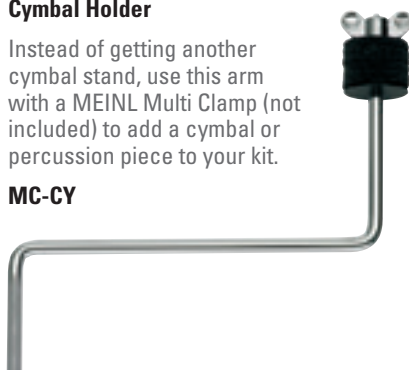

Attaches to any cymbal stand

Drumstick Holders

So you don't miss a beat when you drop a stick, clamp this holder to your hihat or cymbal stand so you can quickly grab a stick.

- MC-DSH** Black
- MC-DSH-JB** Jawbreaker



NEW! X-Hat Auxiliary Hihat Arm with Clamp

The MEINL X-Hat Auxiliary Hihat Arm keeps a pair of hihat or stack cymbals in a stationary position anywhere on a drum set-up. The clamp and boom arm make it easy to attach and position at any height or angle. The tension adjustment makes it possible to finely adjust the degree of opening of the top and bottom cymbal.

MXH

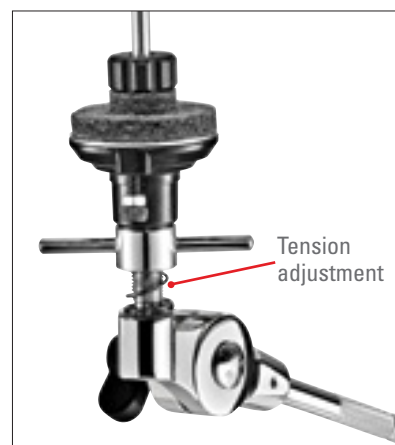

Tension adjustment

DRUM GEAR

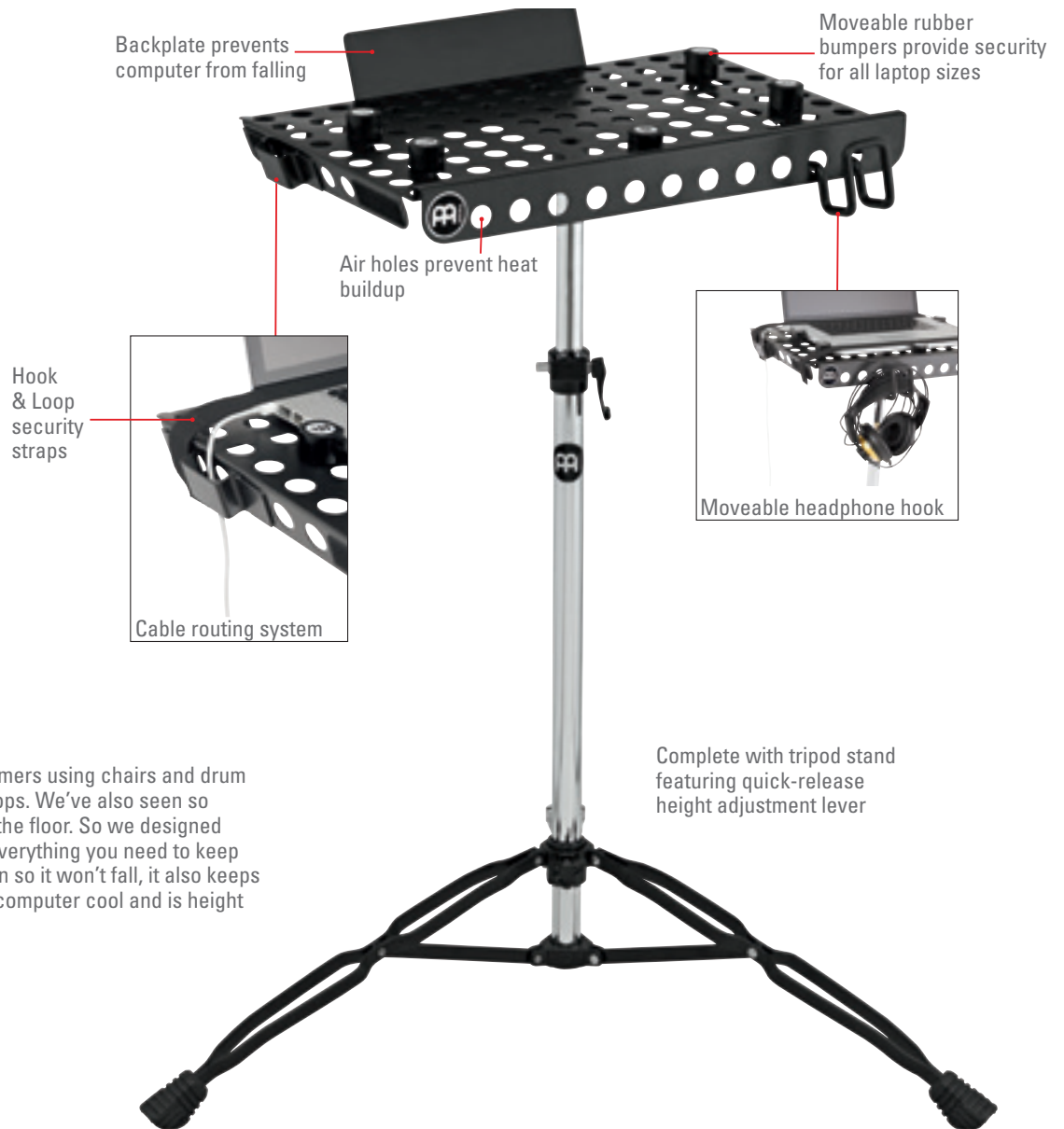

Laptop Table

We have seen so many drummers using chairs and drum cases as tables for their laptops. We've also seen so many of those laptops fall to the floor. So we designed the Laptop Table. Featuring everything you need to keep your computer strapped down so it won't fall, it also keeps cables organized, keeps the computer cool and is height adjustable.

TMLTS

MOUNTABLE TABLES

Jawbreaker Percussion Table

Great for holding onstage accessories.

MC-PT-JB 18" x 12"



MC-PTXS 11" x 7"



Percussion Tables

Made from durable materials and offer enough room for all common drum gear instruments. The angle of the tables can be adjusted.



MC-PTS 12" x 12"



CLEAN & PROTECT



MCKC-MCCL Cymbal Cleaner & Cymbal Protectant



MCKC-MCP Cymbal Polish & Cymbal Protectant



MCCL Cymbal Cleaner
Ideal for cleaning Brilliant and Traditional finish cymbals.



MCP Cymbal Polish
Cleans and polishes Brilliant finish cymbals in one spray-and-wipe procedure.



MCPR Cymbal Protectant
Seals and protects cymbal surface.



Candela

Creative and Exotic Sounds

MEINL Candela cymbals have been specially developed to meet all of the requirements for today's modern percussionists. The Candela series features light, extra thin cymbals, which reveal their full sound potential when played by hand.

PERCUSSION SPLASH

10" CA10S



PERCUSSION HIHAT

10" CA10PH



PERCUSSION CRASHES

14" CA14C

16" CA16C



TIMBALES CRASH-RIDE

18" CA18CR



PERCUSSION JINGLE BELL

14" CA14PJB





Symphonic Cymbals

HANDCRAFTED MASTERPIECES

Entirely hand hammered from premium B20 Bronze in our Turkish Cymbal Smithy, these masterpieces satisfy the highest sonic requirements of orchestral music.



MEINL
Symphonic Cy

ACCESSORIES

HAND CYMBAL STAND

Strong and solid design with three double-braced legs. The two padded cymbal cradles are easily adjustable by a standard drum key. A shelf is added between the two cymbal cradles for different drum accessories.



TMHCS

SUSPENDED CYMBAL STAND

The Suspended Cymbal Stand is specifically engineered to support the cymbal as it swings freely in all directions, in order to produce its maximum sound. Designed to hold cymbals up to 24" in diameter. A cymbal stacker can be attached on top of the gooseneck for an additional cymbal.



TMSCS

LEATHER HANDLES

Made from the finest leather to satisfy the highest demands. Perfect grabbing a hold of quickly and recommended for orchestral applications.



BR1 (pair)

NEW!

TUNING FORK 440 Hz

The Tuning Fork is made in Germany and tuned precisely to the Standard Pitch of 440 Hz. The tuning fork features an ergonomic shaped grip for comfort.



TF-440

SYMPHONIC CYMBALS

THIN

16" SY-16T
18" SY-18T
20" SY-20T
22" SY-22T



MEDIUM

16" SY-16M
18" SY-18M
20" SY-20M
22" SY-22M



MEDIUM HEAVY

19" SY-19MH



HEAVY

16" SY-16H
18" SY-18H
20" SY-20H
22" SY-22H



EXTRA HEAVY

20" SY-20EH
22" SY-22EH



SYMPHONIC SUSPENDED CYMBALS

SUSPENDED

14" SY-14SUS
16" SY-16SUS
17" SY-17SUS
18" SY-18SUS
20" SY-20SUS
22" SY-22SUS





MARCHING CYMBALS

- PROFESSIONAL RANGE - B12 AND B10 BRONZE

are used for the professional marching range. These professional sounding cymbal pairs are tonally matched.

- STUDENT RANGE - B8 BRONZE AND BRASS

is used for the student marching range. They are pressed into shape, are tonally matched and are the perfect choice for the ambitious beginner.



PROFESSIONAL RANGE

B12

- 16" MA-B12-16M
- 18" MA-B12-18M
- 20" MA-B12-20M



B10

- 16" MA-B10-16M
- 18" MA-B10-18M
- 20" MA-B10-20M



ARENA

- 16" MA-AR-16
- 18" MA-AR-18



LEATHER STRAPS

PROFESSIONAL

Made from the finest leather for the ultimate in comfort. The strap has a soft surface and the pad provides excellent protection for the hands.



BR5 (pair)

STANDARD

Standard cymbal strap made from leather. It comes with a pad, which provides excellent protection for the hands.



BR3 (pair)

MARCHING

Specially designed marching leather strap made out of the finest thin leather with extra length in order to easily hold the cymbals in the traditional marching grip.



BR2 (pair)

STUDENT RANGE

BRONZE

- 14" MA-BO-14M
- 16" MA-BO-16M
- 18" MA-BO-18M



BRASS

- 13" MA-BR-13M
- 14" MA-BR-14M
- 16" MA-BR-16M
- 18" MA-BR-18M





CYM-CATALOG17



8 40553 01834 9