

THE ULTIMATE SELECTION



**THE MEINL BOOK
OF PERCUSSION**

2013



THE ULTIMATE SELECTION
EXCLUSIVELY PRESENTED BY **MEINL**

2013



THE MEINL ARTIST FAMILY

ARTIST FAMILY





THE MEINL ARTIST FAMILY

ARTIST FAMILY



KJ Sawka, UK



Konrad Graf, Germany



Larry Salzman, USA



Ralf Gustke, Germany



Ramesh Shotham, Germany



Raul Maldonado, Puerto Rico



Justin Porees, USA



Jiro Yamaguchi, USA

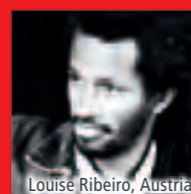

Louise Ribeiro, Austria



Luis Conte, USA



Luis Palacios, Cuba

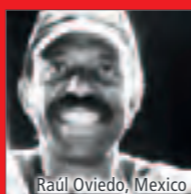

Raul Oviedo, Mexico



Riaan VanRensburg, South Africa



Rigo Collazo, Puerto Rico



Roland Peil, Germany



Roel Galister, Netherlands



Ludo Srnec, Slovakia



Marcie Chapa, USA



Marco Catinaccio, Italy



Mark Essien, Germany



Matthias Meusel, Germany



Robbie Harris, Ireland



Roberto Santamaria, Cuba



Rodney Holmes, USA



Marcio Peeter, USA



Miguel Fenton, Canada



Mike Johnston, USA



Miloš Vacik, Czech Republic



Monojit Dutta, India

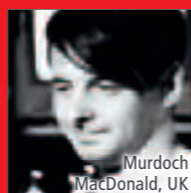

Murdoch MacDonald, UK



Ron van Stratum, Netherlands



Ruediger Maul, Germany



Stephan Maass, Germany



Russ Miller, USA



Sabine Vieten, Germany



Max Klaas, Germany



Miguel Fenton, Canada



Mike Johnston, USA



Miloš Vacik, Czech Republic



Monojit Dutta, India

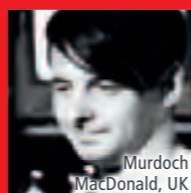

Murdoch MacDonald, UK



Shyam Edwankar, India



Simon Millumby, Australia



Muthu Kumar, India



Nick D'Virgilio, USA



Noby Lehmann, Switzerland



Norman Bonink, Netherlands



Oliver Gatringer, Austria



Stef Broks, Netherlands



Taku Hirano, USA



Stuart Pringle, UK



Suat Borazan, Turkey



Paolo Gimmino, Italy



Nebojsa Jovan Zivkovic, Germany



Onkel, Germany



Pablo Cepeda, Sweden



Tamba Gwindi, Trinidad and Tobago



Tarcisio Molinaro, Italy



Thomas Eby, Sweden



Thomas Lang, Austria



Paul Walsham, UK



Peppe Sannino, Italy

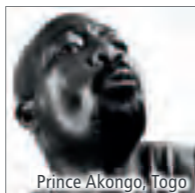

Prince Akongo, Togo



Paul Martinez, Spain

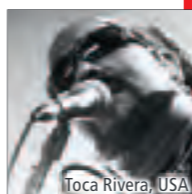

Toca Rivera, USA



Tommy Cluefetos, USA



Trevor Lawrence Jr., USA



Wolfgang Haffner, Germany



Yoel Paez, Spain



Yogi Jockusch, Germany



Yuvisney Aguilar, Spain



Zhang Hongchun, China



WHAT'S NEW IN 2013

MORE THAN 130 NEW ITEMS

MEINL Percussion is proud to be the leading developer of percussion instruments. We work hard to stimulate the market and broaden musical horizons with our ultimate selection.

Here is an over-view of what's new in our line-up for 2013.

We have more than 130 new items, something in almost every category and price range.



MARATHON® CLASSIC SERIES CONGA SET



RAPC (RADIAL PLY CONSTRUCTION) BONGOS

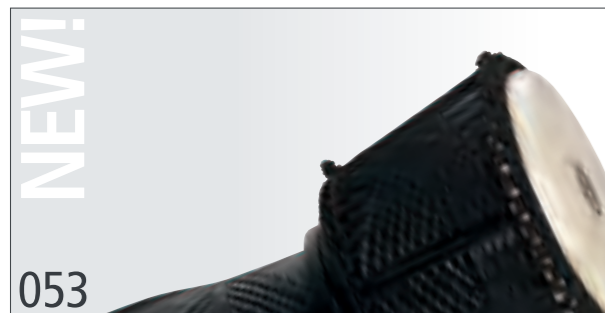

DJEMBEFOLAS



ARTISAN EDITION DOUMBEEKS



ARTISAN EDITION FLAMENCO CAJONS

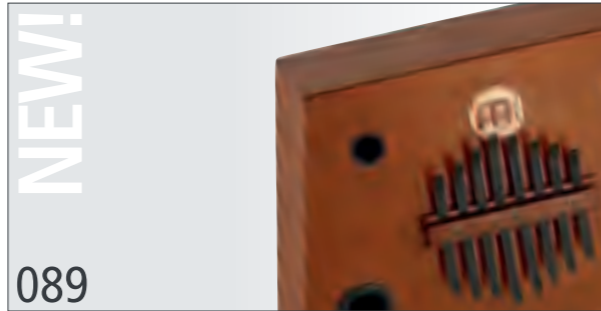

MARIMBULA



MAKE YOUR OWN CAJON



CAJON ADD-ONS



MARATHON® SERIES TIMBALES



ARTISAN EDITION TARS & MIZHARS



HEADED ARTISAN EDITION TAMBOURINES



TURBO CRASHER



ARTIST SERIES DIDGERIDOO

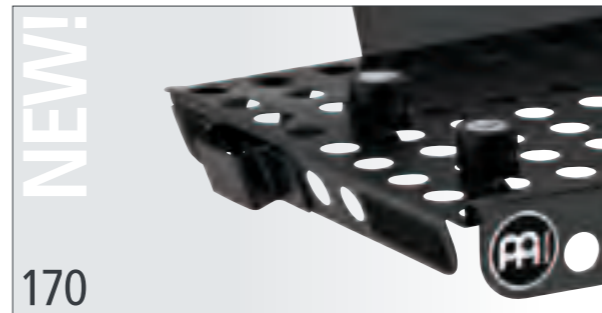

LAPTOP TABLE STAND

INDEX

A-Go-Go's	114	Kalimbas	149
Bags	174	Kanjira	121
Batas	072	Maracas	156
Bendirs	120	Marimbula	089
Berimbau	072	Merchandise	182
Blocks	143/148	Metal Effects	144
Bodhrans	121	Mizhars	119/123
Bongo Cajons	089	Palito	089
Bongos	038	Pandeiros	125
Bougarabou	052	Rainmakers	158
Cabastas	148	Ramwong	073
Caixas	111	Rebolo	112
Cajita	089	Repiniques	111
Cajons	078	Ritual Drums	072
Cajon Add-Ons	093	Rocars	113
Cajons – Make Your Own	090	Samba/Brazilian	108
Candela Percussion Cymbals	162	Sea Drums	124
Castanets	149	Shakers	114/152/157
Chimes	146	Shekeres	073
Claves	150	Slap-Top Cajon	088
Congas	018	Sleigh Bells	148
Conguitas	073	Sound Effects	151
Cowbells	140	Stands	166
Cuicas	113	Sticks/Beaters	164
Dafs	121	Subwoofer Cajon	088
Dancing Percussion	059	Surdos	108
Darbukas	064	Tablas	070
Didgeridoos	159	Tables	170
Djembefolas	053	Talking Drums	072
Djembes	048	Tambora	073
Doumbeks	066	Tambourines	128
Foot Percussion	092	Tampeiro/Tamborims	115
Frame Drums	118	Tantam	112
Güiras/Güiros	148/157	Tars	118/123
Hand-Bale	103	Timbales	096
Hand Drums	124	Timbales – Drummer	102
Hand Percussion	148/157	Timbas	112
Hardware	172	Travel Cajon	094
Ibo Drums	074	Trejon	088
Jingle Sticks	139	Triangles	145

AND MANY MORE...



IT'S A LONG ROAD

from an idea, to a working prototype, to the finished instrument. There's a lot of testing, refining and more testing along the way. What kind of wood to use? What size? How will all that affect the sound? And so on. It has to come together in a way that not only sounds great, but is also playable and durable. It's our passion for details that makes MEINL different. We put together creative people's ideas, with German engineering and modern production facilities. MEINL has become a world leader in percussion by seeing the creative process through, from inspiration to finished instrument.



THE MIPA AWARD GOES TO...

Our Research & Development process is a collaboration between very creative people: Players and designers. We are all passionate about what we do. The MEINL Percussion approach to R & D is open-minded, straightforward, and based on mutual respect. That's how we get things done. That's why MEINL won the most MIPA awards of all percussion brands.



...the **MEINL Slap-Top Cajon**
in the category "Best Percussion Product 2012".



...the **MEINL Foot Cabasa**
in the category "Best Percussion Product 2008".



...the **MEINL Conga Cajon**
in the category "Best Percussion Product 2006".



...the **MEINL Artist Series Congas (Luis Conte)**
in the category "Best Percussion Product 2005".



...the **MEINL Professional Series Congas**
in the category "Best Percussion Product 2002".



...the **MEINL Journey Series Rope Tuned Fiberglass Djembe**
in the category "Best Percussion Product 2011".



...the **MEINL Artist Series Hand-Bale (Taku Hirano)**
in the category "Best Percussion Product 2010".



...the **MEINL Collection Series Wood Bongo**
in the category "Best Percussion Product 2001".



...the **MEINL Artist Series Timbales (Luis Conte)**
in the category "Best Percussion Product 2000".



IT'S OUR WORLD, WE CARE FOR IT

Actions speak louder than words! This is why we take our responsibility seriously and commit ourselves to several environmental projects. Our specially developed vacuum distillation saves 90,000 liters of drinking water, the world's most threatened resource. In order to minimize our electricity usage, all of our buildings are equipped with motion sensors and our centralized electricity controls prevents the waste of this resource. With our solar-power-plant (Photovoltaic-System) we produce enough power to supply 170 houses with electricity. All of the electricity used in our facility is produced from renewable energies. Thus we reduced our carbon monoxide emission from 216 tons per year down to zero. Reusable materials like paper, plastic or styrofoam are too precious to be wasted. We separate them for efficient recycling.



RUBBER WOOD PLANTATION FARM IN THAILAND



WOOD FROM ENVIRONMENTALLY CONTROLLED WOOD PLANTATION

Thailand is a logical manufacturing base for percussion instruments due to the fact that the *Hevea Brasiliensis*, which was indigenous to Brazil and later transported by way England to Asia, has been commercially grown in Southeast Asia during the last century on plantation farms for the production of Latex. The traditional plantation of Rubber Wood (*Hevea brasiliensis* Muell.-Arg.) meets all ecological requirements. Same counts for the plantation grown Mahogany Wood from Indonesia, which we use for our Original African Style Rope Tuned Wood Djembes. In a natural evolution, new trees are planted and the older ones, which have ceased to provide latex, are harvested. In this way, plenty of raw material is available and the valuable rain forest eco-system is preserved.

MATERIAL & ECOLOGY

Wood is a raw material which is present in almost every part of our daily life. Trees are an important part of the complex eco-system while healthy forests are imperative for the Earth's atmosphere. Only plantation grown Wood is used for the making of MEINL percussion instruments. This wood fulfils the CITES regulations ("Convention on International Trade in Endangered Species of Wild Fauna and Flora") and originates from environmentally controlled forests from industrial wood plantations.



PROTECT THE WORLD WE LIVE IN

1 ELECTRIC CAR

With a new e-car we are taking another important step towards an environmentally friendly future. The long-lasting lithium ion battery feeds the electrical driving unit of the e-car and offers eco-friendly driving enjoyment of about 80 km through saved energy.

2 CO₂ CONSERVATION

For us it goes without saying that all kinds of trash like paper, cardboard, plastic, styrofoam, organic waste, etc. are separated. As a result of this, we are a member of the official German packaging regulations organization which controls the return of the sales, transport and outer packaging that needs to be licensed in a dual system. By this recirculation of paper, cardboard and synthetic materials, we have conserved 449,238 lb (203,771 kg) of CO₂ in 2011. This equals the emission of a car driving 799,132 miles (1,286,078 km).

3 AIR HEAT PUMP

All of the exhibition area of our new multipurpose hall gets heated by an air heat pump. The fans lead the outside air through the evaporator of the heat pump where the heat gets absorbed from the air. With the outside air there is always free environmental heat available and that makes it possible for us to abandon gas and heating oil. Additionally air heating pumps reduce pollutant and carbon emissions, are long-lasting, reliable and low-maintenance.

4 SAVING ELECTRICITY

To keep our electricity usage at a minimum level, all of the buildings are equipped with motion sensors in order that lights are not left on when our employees aren't there. Additionally, a centralized lighting and machinery control panel prevents the unnecessary waste of electricity.

5 PHOTOVOLTAIC SYSTEM

Since 2003 we have operated our own photovoltaic power plants which have increasingly grown in size to this very day. Today all of our six solar facilities generate a total of 513,000 kilowatt hours of electricity per year. This equals a CO₂ conservation of 565,485 lb (256,500 kg). With this generated energy we are able to supply 170 households with electricity, or cover more than half of our own power consumption.

6 RENEWABLE ELECTRICITY

All of the electricity used in our facility is produced from renewable energies and comes from water power plants. By doing this we reduce the carbon monoxide emission, which the production of the electricity for our operations would cause if normal energies were used, from 200 tons per year down to zero.



PROTECTING THE ENVIRONMENT IS AN ESSENTIAL PART OF WHAT DEFINES US AND OUR DAY TO DAY ACTIVITIES.

At MEINL Percussion, it is of utmost importance to ensure that all of our operations are being executed utilizing the highest possible level of environmental care and preservation. When buying a MEINL Percussion instrument, you can be sure of this. You have our word.

CHARGING STATION

Refuelling our new e-car is now possible at our on-site charging station. As a special service, visitors to our exhibition hall are allowed to refuel their e-cars for free. Just as with all of the power our company uses, we obtain the energy for the e-car from renewable resources.

PELLET HEATING

Since 2011 we have heated our new multipurpose hall with a pellet heater. Wood is a natural renewable source of energy which is ecologically commendable and converts the carbon-neutral power of the sun into heating energy. Besides that, wood is almost limitlessly available. Compared to other combustible materials, wood pellets emit the lowest carbon and particulate emissions and have the highest points in terms of energy efficiency.



CONGAS

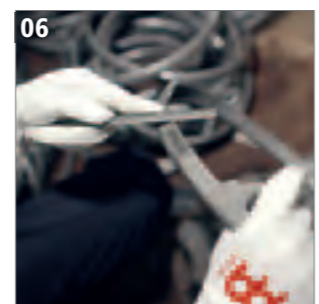

- 01** Rubber Wood stock is sawed to desired thickness for conga staves.
- 02** Glued double-layered staves are bent into shape in a large press.
- 03** After bending, the staves have to be carefully checked for proper shape.
- 04** A set of staves are pre-assembled and glued together by hand.
- 05** The profile is cut by lathe.
- 06** Conga rims are being checked and prepared for the finishing process.
- 07** Sanding a perfect surface is skilled work.
- 08** Logo is hand silk screened on a conga head.



A LOT OF WORK AND QUALITY CONTROL GOES INTO EACH MEINL CONGA BEFORE IT'S READY TO BE PACKED.

MEINL HEADLINER® SERIES CONGAS

HAND SELECTED
BUFFALO HEADS



ERGO-ARCHED RUBBER
BRACING



THESE CONGAS COME WITH HEIGHT
ADJUSTABLE BASKET STANDS



BLACK POWDER COATED
2 MM ROUNDED RIM



8 MM STRONG
TUNING LUGS



RUBBER RINGED BOTTOM FOR MORE
STABILITY WHEN PLAYED WITHOUT STANDS

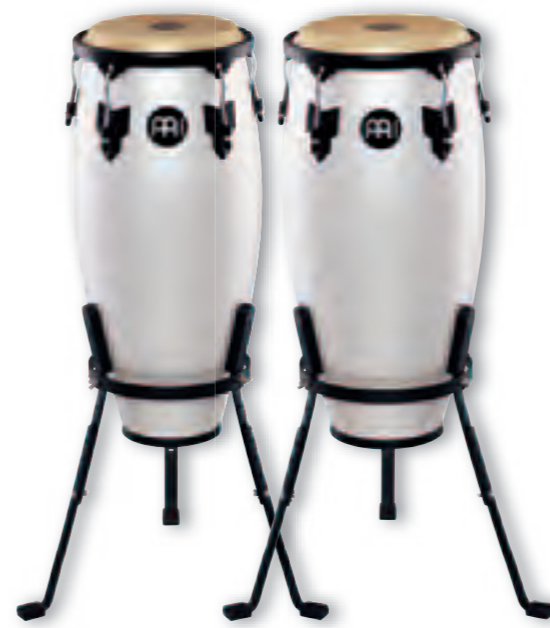

Pearl White, 10" & 11"
HC555PW



Pearl White, 11" & 12"
HC512PW



Maple, 10" & 11"
HC555MA



Maple, 11" & 12"
HC512MA

HEADLINER® SERIES CONGAS

The 10" & 11" pair is the perfect set of congas to get you started! The compact size is easy for young players to handle, light to carry, and has a full, rich sound. You can develop a full foundation of conga techniques and rhythms with these student-friendly drums. The 11" & 12" pair is a full-sized entry level conga set. They have superb projection, warm tones, light weight and features found on professional congas. They offer outstanding quality and great value in the budget price range. This is a pair of congas you will want to keep around as you develop your skills.

- SIZES** **HC555:** 10" & 11" conga set
HC512: 11" & 12" conga set
28" tall
- MATERIAL** Rubber Wood
(*Hevea brasiliensis* Muell.-Arg.)
- FEATURES** Hand selected buffalo heads
8 mm strong tuning lugs
Original MEINL style tuning brackets
2 mm rounded rims
Black powder coated hardware
- INCLUDES** Height adjustable basket stands (patented) with quick set up system
Tuning key

- COLOURS** **MA:** Maple
PW: Pearl White
- FINISH** High gloss
- PATENTS** Basket Stand patents:
Ergo arched rubber bracing
(CN, DE, US patent)
U-shaped notch (US patent)
L-shaped leg (DE patent)

CONGAS

1



Black, 10" & 11"
HC555BK



Black, 11" & 12"
HC512BK



Wine Red Burst, 10" & 11"
HC555WRB



Wine Red Burst, 11" & 12"
HC512WRB



Vintage Sunburst, 10" & 11"
HC555VSB



Vintage Sunburst, 11" & 12"
HC512VSB



Natural, 10" & 11"
HC555NT



Natural, 11" & 12"
HC512NT

1 HEADLINER® SERIES CONGAS

The 10" & 11" pair is the perfect set of congas to get you started! The compact size is easy for young players to handle, light to carry, and has a full, rich sound. You can develop a full foundation of conga techniques and rhythms with these student-friendly drums. The 11" & 12" pair is a full-sized entry level conga set. They have superb projection, warm tones, light weight and features found on professional congas. They offer outstanding quality and great value in the budget price range. This is a pair of congas you will want to keep around as you develop your skills.

SIZES	HC555: 10" & 11" conga set HC512: 11" & 12" conga set 28" tall
MATERIAL	Rubber Wood (<i>Hevea brasiliensis</i> Muell.-Arg.)
FEATURES	Hand selected buffalo heads 8 mm strong tuning lugs Original MEINL style tuning brackets 2 mm rounded rims Black powder coated hardware
INCLUDES	Height adjustable basket stands (patented) with quick set up system Tuning key

COLOURS	BK: Black NT: Natural VSB: Vintage Sunburst WRB: Wine Red Burst
FINISH	High gloss
PATENTS	Basket stand patents: Ergo arched rubber bracing (CN, DE, US patent) U-shaped notch (US patent) L-shaped leg (DE patent)

2 CONGA SAVERS

Available for 8 mm and 10 mm tuning lugs, the MEINL Conga Savers are placed over the conga lugs to prevent them from damaging and scratching the shell while the conga remains fully tunable.

PATENT MEINL Conga Saver (CN, TH, US patent)



CONGA-SAVER8

CONGA-SAVER10





HEADLINER® DESIGNER SERIES CONGAS

1



NEW!



PHANTOM BLACK

Phantom Black, 10"
HC10PBK-M

Phantom Black, 11"
HC11PBK-M

Phantom Black, 12"
HC12PBK-M

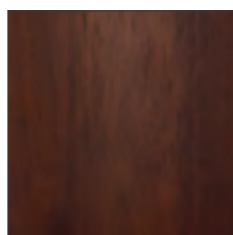

VINTAGE WINE BARREL

Vintage Wine Barrel, 10"
HC10VWB-M

Vintage Wine Barrel, 11"
HC11VWB-M

Vintage Wine Barrel, 12"
HC12VWB-M

HEADLINER® TRADITIONAL DESIGNER SERIES CONGAS



WALNUT BROWN



Cubano Retro, 10"
HTC10WB-M

Cubano Retro, 11"
HTC11WB-M

Cubano Retro, 12"
HTC12WB-M



1 HEADLINER® DESIGNER SERIES CONGAS

These congas are offered individually, and you can make up a trio of the three singles: Nino, Quinto and Conga. These three sizes create a full tonal range.

SIZES 10" Nino, 11" Quinto, 12" Conga
28" tall

MATERIAL Rubber Wood
(*Hevea brasiliensis* Muell.-Arg.)

FEATURES Hand selected buffalo heads
8 mm strong tuning lugs
Original MEINL style tuning brackets
2 mm rounded rims
Black powder coated hardware
HTC: 5 mm traditional TTR-Rims

INCLUDES Height adjustable basket stands (patented) with quick set up system
Tuning key

DESIGNS **PBK-M:** Phantom Black
VWB-M: Vintage Wine Barrel
WB-M: Walnut Brown

FINISH Matte

PATENTS Basket stand patents:
Ergo arched rubber bracing (CN, DE, US patent)
U-shaped notch (US patent)
L-shaped leg (DE patent)



CARLOS MALDONADO, PUERTO RICO

2 CONGA SOUND PLATE

The MEINL Conga Sound Plate is a sturdy wooden disc that provides a hard sound reflective surface under your conga.

SIZE 13 1/4"
MATERIAL Rubber Wood
(*Hevea brasiliensis* Muell.-Arg.)

3 CONGA RISERS

The MEINL Conga Risers are sturdy rubber feet that raise your drums off the floor to allow maximum sound projection. A set of four provides a stable base on any surface.

MATERIAL Sturdy rubber
FEATURES Comes in a set of four
Flexible construction
COLOUR **BK:** Black

2



CSP

3

FITS UNDER ANY CONGA



MCR-BK

COMES IN A SET OF 4



Natural, 10" & 11"
HC888NT



Natural, 11" & 12"
HC812NT



Vintage Sunburst, 10" & 11"
HC888VSB



Vintage Sunburst, 11" & 12"
HC812VSB



Wine Red Burst, 10" & 11"
HC888WRB



Wine Red Burst, 11" & 12"
HC812WRB



Antique Tobacco Burst, 11" & 11 3/4"
MCC-SET-ATB-M

1 2 3 4 5 6 HEADLINER® SERIES CONGA SETS

Get started with the MEINL Headliner® Series Conga Sets. They offer outstanding quality and great value in the budget price range, yet are equipped with many features known from professional instruments. These conga sets come with a height adjustable double braced tripod stand.

- SIZES** **HC888:** 10" & 11" conga set
HC812: 11" & 12" conga set
28" tall
- MATERIAL** Rubber Wood
(*Hevea brasiliensis* Muell.-Arg.)
- FEATURES** Hand selected buffalo heads
8 mm strong tuning lugs
Original MEINL style tuning brackets
2 mm rounded rims
Black powder coated hardware
- INCLUDES** Height adjustable double braced tripod stand
Tuning key
- COLOURS** **NT:** Natural
VSB: Vintage Sunburst
WRB: Wine Red Burst
- FINISH** High gloss



JARRENGTON DE LEON,
DOMINICAN REPUBLIC

7 MARATHON® CLASSIC SERIES CONGA SET

The MEINL Marathon® Classic Series Conga Set combines professional features at a very attractive price. This conga set is equipped with a height adjustable double braced tripod stand.

- SIZES** 11" Quinto, 11 3/4" Conga
30" tall
- MATERIAL** Rubber Wood
(*Hevea brasiliensis* Muell.-Arg.)
- FEATURES** True Skin Buffalo Heads
8 mm strong tuning lugs
2.6 mm rounded SSR-Rims
Black powder coated hardware

- INCLUDES** Height adjustable double braced tripod stand
MEINL Conga Saver (patented)
Accessory pouch
L-shaped tuning key
Tune Up Oil
- COLOUR** **ATB-M:** Antique Tobacco Burst, matte
- PATENT** MEINL Conga Saver (CN, TH, US patent)

1



Black, 10"
HFC10BK

Black, 11"
HFC11BK

Black, 12"
HFC12BK

PREMIUM FIBERGLASS GUARANTEES LONG DURABILITY AND RESISTANCE TO CLIMATIC CHANGES

2



Luis Conte



Natural, 11"
LC11NT-M

Natural, 11 3/4"
LC1134NT-M

Natural, 12 1/2"
LC1212NT-M



A COMBINATION OF THE CHARM AND SOUND OF THE OLD TRADITIONAL CUBAN DRUMS WITH MODERN FEATURES AND INNOVATIONS

1 HEADLINER® FIBERGLASS SERIES CONGAS

This material has long been used for congas shells because of its durability and resistance to climactic changes, while offering a full spectrum and brilliance in sound.

SIZES 10" Nino, 11" Quinto, 12" Conga 28" tall

MATERIAL Premium fiberglass

FEATURES Hand selected buffalo heads
8mm strong tuning lugs
Original MEINL style tuning brackets
2mm rounded rims
Black powder coated hardware

INCLUDES Height adjustable basket stands (patented) with quick set up system
Tuning key

COLOUR **BK:** Black

2 ARTIST SERIES LUIS CONTE CONGAS

All of Luis' needs have been met and exceeded with the MEINL Artist Series Luis Conte Congas. They combine the charm and sound of the old traditional Cuban drums with modern features and innovations. These congas are equipped with traditional rims, are mounted as close to the shell as possible, and when combined with MEINL's True Skin Buffalo Heads, they enable an even more controlled sound.

SIZES 11" Quinto, 11 3/4" Conga, 12 1/2" Tumba 30" tall

MATERIAL Two ply Rubber Wood (Hevea brasiliensis Muell.-Arg.)

FEATURES True Skin Buffalo Heads
8 mm strong tuning lugs
5 mm traditional TTR-Rims
Black powder coated hardware

INCLUDES MEINL Conga Saver (CN, TH, US patent)
MEINL Soundpads
Accessory pouch
L-shaped tuning key
Tune Up Oil

COLOUR **NT-M:** Natural

FINISH Matte

1



DESIGN INSPIRED BY TAKU HIRANO, USA



Mitsudomoe, 11"
MCC11M

Mitsudomoe, 11 3/4"
MCC1134M

Mitsudomoe, 12 1/2"
MCC1212M

2



Love, Peace & Unity, 11"
MCC11LPU

Love, Peace & Unity, 11 3/4"
MCC1134LPU

Love, Peace & Unity, 12 1/2"
MCC1212LPU



DESIGN INSPIRED BY MARCIE CHAPA, USA

1 MITSUDOMOE

This Marathon® Designer Series Congas matches Taku Hirano's playing style: elegant, captivating and versatile. The congas are proudly emblazoned with the Japanese Mitsudomoe symbol, representing Man, Earth, and Heaven. The symbol became associated with the Samuri ethos, and with the art of drumming itself.

Taku explains, "The Mitsudomoe symbol has always resounded with me in that it was a link to my heritage and synonymous to not only the warriors of Japan, but also the drummers of Japan. After doing research and finding out that it was adopted by a king with the same name as myself, and that it symbolized upholding honour to the highest degree, I knew that it chose me as much as I chose it."

2 LOVE, PEACE & UNITY

Marcie Chapa sends an important message to the world with the Marathon® Designer Series Congas: "Love, Peace & Unity" "I fall in love with music each time I play." says Marcie. "Peace reminds me of where we should be. Every time I play I feel at Peace. Music has amazing powers because it is an international language that can bring Peace, Love, and Unity to us all."

SIZES 11" Quinto, 11 3/4" Conga, 12 1/2" Tumba 30" tall

MATERIAL Rubber Wood with appliqué graphics (Hevea brasiliensis Muell.-Arg.)

FEATURES True Skin Buffalo Heads
8 mm strong tuning lugs
2.6 mm rounded SSR-Rims
Black powder coated hardware

INCLUDES Steely II Conga Stand (patented)
MEINL Conga Saver (CN, TH, US patent)
Accessory pouch
L-shaped tuning key
Tune Up Oil

DESIGNS **LPU:** Love, Peace & Unity

M: Mitsudomoe

FINISH High gloss

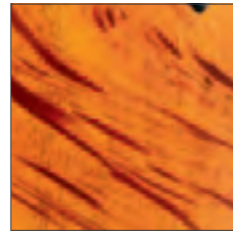

AMBER FLAME

Amber Flame, 11"
MCC11AF

Amber Flame, 11 3/4"
MCC1134AF

Amber Flame, 12 1/2"
MCC1212AF



LEOPARD BURL

Leopard Burl, 11"
MCC11LB

Leopard Burl, 11 3/4"
MCC1134LB

Leopard Burl, 12 1/2"
MCC1212LB

MARATHON® DESIGNER SERIES CONGAS
The Marathon® Designer Series Congas are made with a special lacquering technique in high gloss, have professional features and are available at a very attractive price.

SIZES 11" Quinto, 11 3/4" Conga, 12 1/2" Tumba
30" tall

MATERIAL Two ply Rubber Wood (*Hevea brasiliensis* Muell.-Arg.)

FEATURES True Skin Buffalo Heads
8 mm strong tuning lugs
2.6 mm rounded SSR-Rims
Black powder coated hardware

INCLUDES Steely II Conga Stand (patented)
MEINL Conga Saver (CN, TH, US patent)
Accessory pouch
L-shaped tuning key
Tune Up Oil

COLOURS **AF:** Amber Flame
LB: Leopard Burl

FINISH High gloss



JOANNIE LABELLE, CANADA



SUPER NATURAL

Super Natural, 11"
MCC11SNT-M

Super Natural, 11 3/4"
MCC1134SNT-M

Super Natural, 12 1/2"
MCC1212SNT-M

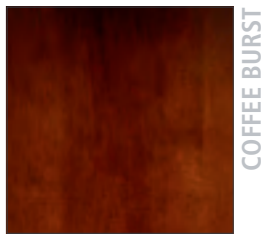

COFFEE BURST

Coffee Burst, 11"
MCC11CB

Coffee Burst, 11 3/4"
MCC1134CB

Coffee Burst, 12 1/2"
MCC1212CB

MARATHON® CLASSIC SERIES CONGAS
The MEINL Marathon® Classic Series Congas set the standard in this price range by which other wood congas are judged. They combine professional features at a very attractive price.

SIZES 11" Quinto, 11 3/4" Conga, 12 1/2" Tumba
30" tall

MATERIAL Two ply Rubber Wood (*Hevea brasiliensis* Muell.-Arg.)

FEATURES True Skin Buffalo Heads
8 mm strong tuning lugs
2.6 mm rounded SSR-Rims
Black powder coated hardware

INCLUDES Steely II Conga Stand (patented)
MEINL Conga Saver (patented)
Accessory pouch
L-shaped tuning key
Tune Up Oil

COLOURS **CB:** Coffee Burst, high gloss
SNT-M: Super Natural, matte

PATENTS Steely-II patents:
L-shaped leg and metal spike attachment (DE, TH, US patent)
U-shaped notch (US patent)
Ergonomic arched rubber bracing (CN, DE, US patent)
Notches for quick height adjustability (DE patent)
MEINL Conga Saver (CN, TH, US patent)



THE STEELY II STAND CAN BE ADJUSTED TO HOLD CONGAS IN A TILTED POSITION



BROWN BURL

Brown Burl, 11"
MP11BB

Brown Burl, 11 3/4"
MP1134BB

Brown Burl, 12 1/2"
MP1212BB



NATURAL

Natural, 11"
MP11NT

Natural, 11 3/4"
MP1134NT

Natural, 12 1/2"
MP1212NT

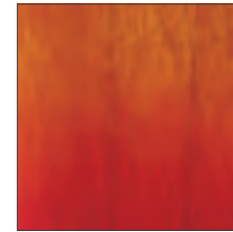

AZTEC RED FADE

Aztec Red Fade, 11"
MP11ARF

Aztec Red Fade, 11 3/4"
MP1134ARF

Aztec Red Fade, 12 1/2"
MP1212ARF



GIOVANNI IMPARATO, ITALY



CHROME PLATED 4 MM ROUNDED SSR-RIM

PROFESSIONAL SERIES CONGAS

The Roland Meinl Professional Series Congas are the preferred conga model by many top congueros. Outstanding in look and sound, they reach from fat basses to cutting slaps with a great warm overall tone. They set the standard in the professional conga ranges.

SIZES 11" Quinto, 11 3/4" Conga, 12 1/2" Tumba, 30" tall

MATERIAL Two ply Rubber Wood (*Hevea brasiliensis* Muell.-Arg.)

FEATURES True Skin Buffalo Heads, 10 mm strong tuning lugs, 4 mm rounded SSR-Rims, Chrome plated hardware

INCLUDES MEINL Conga Saver (CN, TH, US patent), MEINL Soundpads, Accessory pouch, L-shaped tuning key, Tune Up Oil

COLOURS **ARF:** Aztec Red Fade, **BB:** Brown Burl, **NT:** Natural

FINISH High gloss



TMC-CH

PROFESSIONAL CONGA STAND (SEE PAGE 166)



BLUE SPARKLE

Blue Sparkle, 11" **FC11BSP** Blue Sparkle, 11 3/4" **FC1134BSP** Blue Sparkle, 12 1/2" **FC1212BSP**

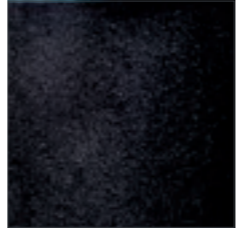

BLACK SPARKLE

Black Sparkle, 11" **FC11BKSP** Black Sparkle, 11 3/4" **FC1134BKSP** Black Sparkle, 12 1/2" **FC1212BKSP**



RAUL OVIEDO, MEXICO

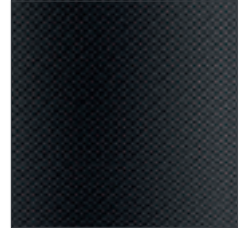

CRISP AND CLEAN CARBON FINISH

Carbon Finish, 11" **FC11CA** Carbon Finish, 11 3/4" **FC1134CA** Carbon Finish, 12 1/2" **FC1212CA**



FIBERCRAFT SERIES CONGAS

MEINL Fibercraft Congas offer great quality, durability, volume, and they are resistant to climatic changes. They have a great presence and brilliance in sound. Great for live playing and extensive road use.

SIZES 11" Quinto, 11 3/4" Conga, 12 1/2" Tumba 30" tall

MATERIAL Premium fiberglass

FEATURES True Skin Buffalo Heads
10 mm strong tuning lugs
4 mm rounded SSR-Rims
Chrome plated hardware

INCLUDES MEINL Conga Saver (CN, TH, US patent)
MEINL Soundpads
Accessory pouch
L-shaped tuning key
Tune Up Oil

COLOURS **BKSP:** Black Sparkle
BSP: Blue Sparkle



TRUE SKIN BUFFALO HEAD

FIBERCRAFT DESIGNER SERIES CONGAS

The MEINL Fibercraft Designer Series Congas come in a dazzling carbon finish. These congas are made from premium fiberglass for dependability and great sound characteristics.

SIZES 11" Quinto, 11 3/4" Conga, 12 1/2" Tumba 30" tall

MATERIAL Premium fiberglass
FEATURES True Skin Buffalo Heads
10 mm strong tuning lugs
4 mm rounded SSR-Rims
Chrome plated hardware

INCLUDES MEINL Conga Saver (CN, TH, US patent)
MEINL Soundpads
Accessory pouch
L-shaped tuning key
Tune Up Oil

COLOUR **CA:** Carbon Finish



ST-MCC **ST-FL / ST-MP / ST-WC** **ST-MSA**

STEELY II CONGA STANDS (SEE PAGE 166)



FLOATUNE & ARTIST SERIES CONGAS

1



Brown Burl, 10"
FL10BB

Brown Burl, 11"
FL11BB

Brown Burl, 12"
FL12BB

Brown Burl, 13"
FL13BB

THE FLOATUNE TUNING SYSTEM
ALLOWS THE SHELL TO VIBRATE FREELY.

2



American White Ash, 11"
MSA11AWA

American White Ash, 11 3/4"
MSA1134AWA

American White Ash, 12 1/2"
MSA1212AWA



RAMON "MONGO" SANTAMARIA, CUBA

1 FLOATUNE SERIES CONGAS

The MEINL Floatune Tuning System is a true and unique MEINL innovation. All mounting hardware is completely isolated from the shell. This avoids the need to drill through the shell and mount hardware with bolts, which reduces the resonant vibrations of the shell.

SIZES 10" Nino, 11" Quinto, 12" Conga, 13" Tumba
30" tall

MATERIAL Two ply Rubber Wood (*Hevea brasiliensis* Muell.-Arg.)

FEATURES Floatune Tuning System
True Skin Buffalo Heads
10 mm strong tuning lugs
4 mm rounded SSR-Rims
Chrome plated hardware

INCLUDES MEINL Conga Saver (CN, TH, US patent)
MEINL Soundpads
Accessory pouch
L-shaped tuning key
Tune Up Oil

COLOUR **BB:** Brown Burl

FINISH High gloss

2 ARTIST SERIES CONGAS

(RAMON "MONGO" SANTAMARIA)

Ramon "Mongo" Santamaria was without a doubt one of the most respected conga players ever, and a pioneer of modern Latin Jazz. During the 50's his band "Black Cuban Diamonds" laid down the foundation for an outstanding career.

Ramon recorded dozens of legendary percussion albums. Worldwide Jazz hits, such as "Watermelon Man" in 1963 and the album "Summertime" from 1980 are only two of the many recordings from this great master percussionist. Mongo has inspired more percussionists around the globe than any other conguero.

Mongo Santamaria died at the Baptist Hospital in Miami, USA in February 2003. He was 85 years old. It is with great appreciation and deepest respect that we honour our friend and his life's work with his MEINL Artist Series Mongo Santamaria Congas.

WOODCRAFT SERIES CONGAS

3



Zebra Finished Ash, 11"
WC11ZFA-M

Zebra Finished Ash, 11 3/4"
WC1134ZFA-M

Zebra Finished Ash, 12 1/2"
WC1212ZFA-M



ZEBRA FINISHED ASH



Antique Mahogany Burst, 11"
WC11AMB

Antique Mahogany Burst, 11 3/4"
WC1134AMB

Antique Mahogany Burst, 12 1/2"
WC1212AMB

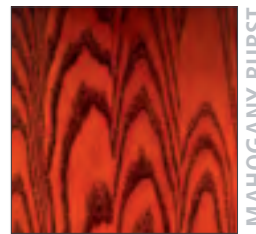

ANTIQUÉ MAHOGANY BURST

3 WOODCRAFT SERIES CONGAS

The MEINL Woodcraft Series Congas stand for tradition combined with exceptional workmanship. Only the finest hand selected materials are used to produce these premium drums. Their "Cuban Style" shells provide a broad range of different tonal characteristics.

SIZES 11" Quinto, 11 3/4" Conga, 12 1/2" Tumba
30" tall

MATERIAL Two ply American White Ash (*Fraxinus americana* L.)

FEATURES True Skin Buffalo Heads
10 mm strong tuning lugs
5 mm traditional TTR-Rims
Chrome plated hardware

INCLUDES MEINL Conga Saver (CN, TH, US patent)
MEINL Soundpads
Accessory pouch
L-shaped tuning key
Tune Up Oil

COLOURS **AMB:** Antique Mahogany Burst, high gloss
ZFA-M: Zebra Finished Ash, matte

SIZES 11" Quinto, 11 3/4" Conga, 12 1/2" Tumba
30" tall

MATERIAL Two ply American White Ash (*Fraxinus americana* L.)

FEATURES True Skin Buffalo Heads
10 mm strong tuning lugs
4 mm rounded SSR-Rims
Gold tone hardware

INCLUDES MEINL Conga Saver (CN, TH, US patent)
MEINL Soundpads
Accessory pouch
L-shaped tuning key
Tune Up Oil

COLOUR **AWA:** American White Ash

FINISH High gloss



BONGOS



01 Staves are matched for colour and grain.



02 The staves are laid up with glue.



03 After being glued, the staves are assembled into a hollow wooden block by hand.

04 The Macho and Hembra are cut into two separate pieces.

05 Precision is a must.

06 The footing profile is also cut on the lathe.

07 The surface and edges are hand-sanded.

08 Our proprietary Free Ride System allows the bongo to resonate freely because there are no bolts or holes drilled through the shells.



BONGOS

MEINL HEADLINER® SERIES BONGOS

1



Black, 6 1/2" & 7 1/2"
HB50BK

STURDY ABS PLASTIC

2



Pearl White, 6 3/4" & 8"
HB100PW



Natural, 6 3/4" & 8"
HB100NT



Wine Red Burst, 6 3/4" & 8"
HB100WRB



ROLAND PEIL, GERMANY



Maple, 6 3/4" & 8"
HB100MA



Vintage Sunburst, 6 3/4" & 8"
HB100VSB

THE COMPACT SIZE MAKES THEM HANDY AND PORTABLE

3



Black, 6 3/4" & 8"
HFB100BK

PREMIUM FIBERGLASS



4



Phantom Black, 6 3/4" & 8"
HB100PBK-M

NEW!



Vintage Wine Barrel, 6 3/4" & 8"
HB100VWB-M



Walnut Brown, 6 3/4" & 8"
HTB100WB-M

5MM STRONG TTR-RIMS

5



Acrylic, 6 1/2" & 7 1/2"
HB50A

CRYSTAL CLEAR ACRYLIC SHELLS



THBS-BK

THBS

HEADLINER® SERIES BONGO STANDS (SEE PAGE 167)

1 HEADLINER® SERIES HB50 ABS BONGO

The MEINL Headliner® Series ABS Bongo has the features of traditional bongos, made from sturdy ABS plastic. The compact size makes it handy and portable.

SIZES 6 1/2" Macho & 7 1/2" Hembra

MATERIAL ABS plastic

FEATURES Hand selected buffalo heads
Rounded rims for playing comfort
Black powder coated hardware

INCLUDES Tuning key

COLOUR **BK**: Black

SIZES 6 3/4" Macho & 8" Hembra

MATERIAL Rubber Wood
(*Hevea brasiliensis* Muell.-Arg.)

FEATURES Hand selected buffalo heads
8 mm strong tuning lugs
2 mm rounded rims
Black powder coated hardware
Interior backing plates

INCLUDES Tuning key

COLOURS **MA**: Maple

NT: Natural

PW: Pearl White

VSB: Vintage Sunburst

WRB: Wine Red Burst

FINISH High gloss

2 HEADLINER® SERIES HB100 WOOD BONGOS

Headliner® Series Wood Bongos are perfect for the student or hobbyist who is looking for a high quality instrument right from the beginning.



TRADITIONAL SOLID WOODBLOCK CONSTRUCTION

INTERIOR BACKING PLATE ADDS STRENGTH TO CONSTRUCTION

3 HEADLINER® SERIES HFB100 FIBERGLASS BONGO

This Bongo has all the traditional features and sounds of a wooden bongo, yet in a rugged and stable premium fiberglass body. It's perfect for the students or hobbyists who are looking for durability from their drum.

SIZES 6 3/4" Macho & 8" Hembra

MATERIAL Premium fiberglass

FEATURES Hand selected buffalo heads
8 mm strong tuning lugs
2 mm rounded rims
Black powder coated hardware

INCLUDES Tuning key

COLOUR **BK**: Black

4 HEADLINER® DESIGNER SERIES HB100/HTB100 WOOD BONGOS

The MEINL Headliner® Designer Series Bongos offer three finishes. The construction is in the traditional style, with a solid woodblock connection.

SIZES 6 3/4" Macho & 8" Hembra

MATERIAL Rubber Wood
(*Hevea brasiliensis* Muell.-Arg.)

FEATURES Hand selected buffalo heads
Rounded rims for playing comfort
Black powder coated hardware
HTB: 5 mm strong TTR-rims

INCLUDES Tuning key

COLOURS **PBK-M**: Phantom Black, matte

VWB-M: Vintage Wine Barrel, matte

WB-M: Walnut Brown, matte

5 HEADLINER® SERIES HB50 ACRYLIC BONGO

The MEINL Headliner® Series Acrylic Bongo has a great look. The crystal clear acrylic shells add a touch of transparency and lightness. The shells are joined together in the traditional style.

SIZES 6 1/2" Macho & 7 1/2" Hembra

MATERIAL Acrylic

FEATURES Hand selected buffalo heads
Rounded rims for playing comfort
Black powder coated hardware

INCLUDES Tuning key

FINISH Transparent



FREE RIDE SERIES WOOD BONGOS

1



Super Natural, 6 3/4" & 8"
FWB190SNT-M

2



Leopard Burl, 6 3/4" & 8"
FWB190LB

NEW!



Antique Tobacco Burst, 6 3/4" & 8"
FWB190ATB-M



Amber Flame, 6 3/4" & 8"
FWB190AF



Cherry Red, 6 3/4" & 8"
FWB190CR-M

DESIGN INSPIRED BY
TAKU HIRANO, USA



Mitsudomoe, 6 3/4" & 8"
FWB190M



Coffee Burst, 6 3/4" & 8"
FWB190CB

DESIGN INSPIRED BY
MARCIE CHAPA, USA



Love, Peace & Unity, 6 3/4" & 8"
FWB190LPU

1 FREE RIDE SERIES (DE PATENT) FWB190 WOOD BONGOS

FWB190 Free Ride Series Wood Bongos are perfect for the ambitious beginner and for those who are looking for an affordable second set. Its professional features are outstanding in this price range.

SIZES 6 3/4" Macho & 8" Hembra

MATERIAL Rubber Wood
(*Hevea brasiliensis* Muell.-Arg.)

FEATURES MEINL Free Ride Suspension System (DE patent)
Black powder coated hardware
Hand selected buffalo heads
8 mm strong tuning lugs
2.5 mm rounded SSR-Rims

INCLUDES Accessory pouch
L-shaped tuning key
Tune Up Oil

COLOURS **ATB-M:** Antique Tobacco Burst, matte
CB: Coffee Burst, high gloss
CR-M: Cherry Red, matte
SNT-M: Super Natural, matte

2 FREE RIDE DESIGNER SERIES (DE PATENT) FWB190 WOOD BONGOS

The Free Ride Designer Series Wood Bongo comes in four superb finishes. All other features are similar to the FWB190 Wood Bongos.

SIZES 6 3/4" Macho & 8" Hembra

MATERIAL Rubber Wood
(*Hevea brasiliensis* Muell.-Arg.)

FEATURES MEINL Free Ride Suspension System (DE patent)
Unique designs
Black powder coated hardware
Hand selected buffalo heads
8 mm strong tuning lugs
2.5 mm rounded SSR-Rims

INCLUDES Accessory pouch
L-shaped tuning key
Tune Up Oil

COLOURS **AF:** Amber Flame
LB: Leopard Burl
LPU: Love, Peace & Unity
M: Mitsudomoe

FINISH High gloss

ARTIST SERIES & FREE RIDE SERIES WOOD BONGOS

1



Natural, 6 3/4" & 8"
LC300NT-M



LUIS CONTE, USA



TRADITIONAL
SOLID WOODBLOCK CONSTRUCTION

2



Gold Amber Sunburst, 6 3/4" & 8"
FWB200GAB



Aztec Red Fade, 6 3/4" & 8"
FWB200ARF

CHROME PLATED
ROUNDED SSR RIM



Natural, 6 3/4" & 8"
FWB200NT

3



Super Natural, 3 1/2" & 4 1/4"
FWB100SNT-M

MINI!

1 ARTIST SERIES LC300 WOOD BONGO (LUIS CONTE)

The Luis Conte Wood Bongo complements his congas with its black powder coated traditional style hardware and natural finish. Luis prefers the traditional style woodblock connection between the two shells.

SIZES 6 3/4" Macho & 8" Hembra

MATERIAL Rubber Wood
(*Hevea brasiliensis* Muell.-Arg.)

FEATURES Solid woodblock connection
True Skin Cow Heads
8 mm strong tuning lugs
5 mm traditional TTR-Rims
Black powder coated hardware

INCLUDES Accessory pouch
L-shaped tuning key
Tune Up Oil

COLOUR **NT-M:** Natural, matte

2 FREE RIDE SERIES (DE PATENT) FWB200 WOOD BONGOS

The patented MEINL Free Ride System allows the bongo shells to resonate freely.

SIZES 6 3/4" Macho & 8" Hembra

MATERIAL Rubber Wood
(*Hevea brasiliensis* Muell.-Arg.)

FEATURES MEINL Free Ride Suspension System (DE patent)
Chrome plated hardware
Hand selected buffalo heads
8 mm strong tuning lugs
2.5 mm rounded SSR-Rims

INCLUDES Accessory pouch
L-shaped tuning key
Tune Up Oil

COLOURS **ARF:** Aztec Red Fade, high gloss
GAB: Gold Amber Sunburst, high gloss
NT: Natural, high gloss

3 FREE RIDE SERIES (DE PATENT) FWB100 MINI WOOD BONGO

The FWB100 is equipped with professional features.

SIZES 3 1/2" Macho & 4 1/4" Hembra

MATERIAL Rubber Wood
(*Hevea brasiliensis* Muell.-Arg.)

FEATURES Free Ride Suspension System (DE patent)
True Skin Buffalo Heads
Rounded SSR-Rims
Chrome plated hardware

INCLUDES Tuning key

COLOUR **SNT-M:** Super Natural, matte



FREE RIDE SERIES FIBERGLASS BONGOS

FREE RIDE SERIES WOOD BONGOS

1



Blue Sparkle, 6 3/4" & 8"
FFB200BSP

SPARKLING EFFECT



Black Sparkle, 6 3/4" & 8"
FFB200BKSP

SPARKLING EFFECT

2



Blue Sparkle, 7" & 8 1/2"
FFB400BSP

SPARKLING EFFECT



Black Sparkle, 7" & 8 1/2"
FFB400BKSP

SPARKLING EFFECT



Carbon Finish, 7" & 8 1/2"
FFB400CA

CRISP AND CLEAN CARBON FINISH



TMB-S

TMB

PROFESSIONAL BONGO STAND & PROFESSIONAL BONGO STAND FOR SEATED PLAYERS (SEE PAGE 167)

1



Natural, 7" & 8 1/2"
FWB400NT



Ebony Black, 7" & 8 1/2"
FWB400EBK



Cherry Red, 7" & 8 1/2"
FWB400CR



Antique Mahogany Burst, 7" & 9"
WB500AMB



Gold Amber Sunburst, 7" & 8 1/2"
FWB400GAB



Zebra Finished Ash, 7" & 9"
WB500ZFA-M



Brown Burl, 7" & 8 1/2"
FWB400BB



American White Ash, 7" & 8 1/2"
CS400AWA-M

CHROME PLATED 5 MM TRADITIONAL TTR RIM

1 FREE RIDE SERIES (DE PATENT) FFB200 FIBERGLASS BONGOS

These fiberglass bongos produce a compact sound with a nice spectrum of overtones. Ideal for the ambitious beginner who is looking for a dependable bongo at an affordable price.

- SIZES** 6 3/4" Macho & 8" Hembra
- MATERIAL** Premium fiberglass
- FEATURES** MEINL Free Ride Suspension System (DE patent)
Chrome plated hardware
Hand selected buffalo heads
8 mm strong tuning lugs
2.5 mm rounded SSR-Rims
- INCLUDES** Accessory pouch
L-shaped tuning key
Tune Up Oil

COLOURS **BKSP:** Black Sparkle
BSP: Blue Sparkle

2 FREE RIDE SERIES (DE PATENT) FFB400 FIBERGLASS BONGOS

These bongos convince with a stunning sound reaching from powerful mids to sharp highs. Thanks to their fiberglass shells they are extremely durable and the perfect instrument for the working musician on the road.

- SIZES** 7" Macho & 8 1/2" Hembra
- MATERIAL** Premium fiberglass

- FEATURES** MEINL Free Ride Suspension System (DE patent)
Chrome plated hardware
True Skin Cow Heads
8 mm strong tuning lugs
3 mm rounded SSR-Rims
Resonance Shaping Area
- INCLUDES** Accessory pouch
L-shaped tuning key
Tune Up Oil

COLOURS **BKSP:** Black Sparkle
BSP: Blue Sparkle
CA: Carbon Finish

FREE RIDE SERIES WOOD BONGOS 1 2 3

- FEATURES** MEINL Free Ride Suspension System (DE patent)
Chrome plated hardware
True Skin Cow Heads
8 mm strong tuning lugs
Resonance Shaping Area
- INCLUDES** Accessory pouch
L-shaped tuning key
Tune Up Oil

1 FREE RIDE SERIES (DE PATENT) FWB400 WOOD BONGOS

The MEINL FWB400 Free Ride Series Wood Bongos are the preferred bongo model by many top percussionists. Exceptional sound qualities combined with a wide variety of colours make it the perfect bongo for the working musician.

- SIZES** 7" Macho & 8 1/2" Hembra
- MATERIAL** Rubber Wood
(*Hevea brasiliensis* Muell.-Arg.)
- FEATURES** 3 mm rounded SSR-Rims
- COLOURS** **BB:** Brown Burl
CR: Cherry Red
EBK: Ebony Black
GAB: Gold Amber Sunburst
NT: Natural
- FINISH** High gloss

2 FREE RIDE SERIES (DE PATENT) WB500 WOODCRAFT BONGOS

MEINL Woodcraft Bongos, just as the Woodcraft Congas, stand for tradition combined with exceptional workmanship. Only the finest hand selected materials are used to produce this premium bongos which produce the authentic loud bongo slap.

- SIZES** 7" Macho & 9" Hembra
- MATERIAL** American White Ash
(*Fraxinus americana* L.)
- FEATURES** 5 mm traditional TTR-Rims
- COLOURS** **AMB:** Antique Mahogany Burst, high gloss
ZFA-M: Zebra Finished Ash, matte

3 FREE RIDE COLLECTION SERIES (DE PATENT) CS400 WOOD BONGO

This is the finest bongo available today! It is made entirely by hand and exhibit unparalleled sound, charm, and workmanship.

- SIZES** 7" Macho & 8 1/2" Hembra
- MATERIAL** American White Ash
(*Fraxinus americana* L.)
- FEATURES** 3 mm rounded SSR-Rims
- COLOUR** **AWA-M:** American White Ash
- FINISH** Matte



HOW WE MAKE IT

THE NEW MEINL RAPC (RADIAL PLY CONSTRUCTION) BONGOS

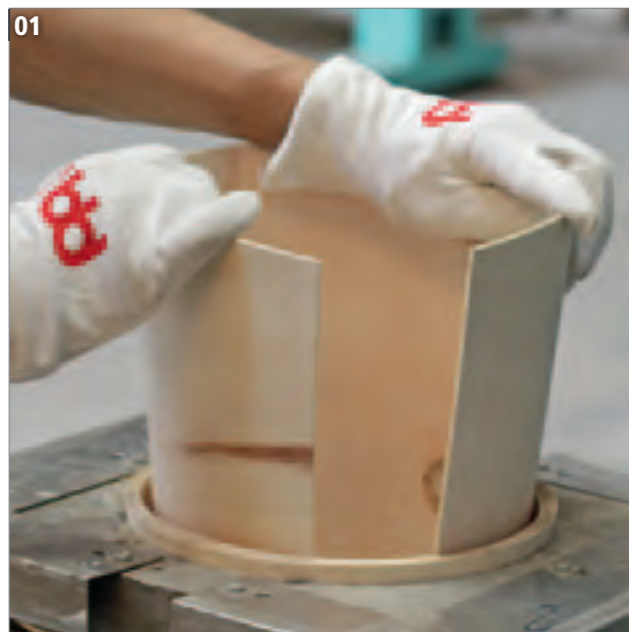

MEINL'S NEW RAPC (RADIAL PLY CONSTRUCTION) FEATURES 5 LAYERS THAT CREATE SUPER STRONG BUT LIGHTWEIGHT BONGO SHELLS WITH ENHANCED RESONANCE.



01 Preparing single wood layers for the Radial Ply Construction.

02 The thin wood layers are placed in the form to set.

03 Quality control check of each MEINL Bongo before it gets packed.



MEINL RAPC BONGOS



Black Maple Burst, 6 3/4" & 8"
MB400BKMB



Cherry, 6 3/4" & 8"
MB400CHE



Ebony Black, 6 3/4" & 8"
MB400EBP



Bubinga, 6 3/4" & 8"
MB400BU



Desert Burl, 6 3/4" & 8"
MB400DB-M

RAPC (RADIAL PLY CONSTRUCTION) BONGOS (DE PATENT)

MEINL's new Radial Ply Construction was adopted from traditional drum-set shell building techniques. It uses several thin layers of wood being formed together to make a super strong shell that is lighter and more resonant. Add to that Meinl's patented Free Ride system that allows the bongos to be joined with NO HOLES DRILLED IN THE SHELLS and you have some serious bongo innovation.

- SIZES** 6 3/4" Macho & 8" Hembra
- MATERIAL** 5 layers of plywood
- FEATURES** MEINL Free Ride Suspension System (DE patent)
RAPC Technology
True Skin Cow Heads
8 mm strong tuning lugs
2.5 mm rounded SSR-Rims
- INCLUDES** Accessory pouch
L-shaped tuning key
Tune Up Oil
- FINISHES** **BKMB**: Black Maple Burst, high gloss
BU: Bubinga, high gloss
CHE: Cherry, high gloss
DB-M: Desert Burl, matte
EBP: Ebony Black, high gloss

DJEMBES

- 01** Raw logs of plantation grown Mahogany Wood.
- 02** Mahogany logs are scaled rough-cut.
- 03** First phase of shaping the djembe on a lathe.
- 04** The interior is hollowed out.
- 05** This is how the djembes look after being turned on the lathe. The central core is later removed.
- 06** The djembes are hand-carved. There is no substitute for this level of craftsmanship.
- 07** The inside of the bowl is hand-carved which tunes and shapes the sound.
- 08** The goatskin head goes on and the tuning ropes are tightened.
- 09** The extra tuning rope is tied into a carrying strap.
- 10** Hand-carved design on our Professional African Style Djembes.

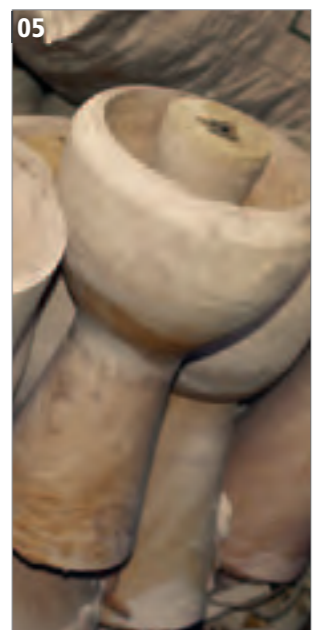

HEADLINER® SERIES ROPE TUNED WOOD DJEMBES



NILE SERIES

Nile Series, 13" **HDJ4-XL** Nile Series, 12" **HDJ4-L** Nile Series, 10" **HDJ4-M** Nile Series, 8" **HDJ4-S**



BLACK RIVER SERIES

Black River Series, 13" **HDJ3-XL** Black River Series, 12" **HDJ3-L** Black River Series, 10" **HDJ3-M** Black River Series, 8" **HDJ3-S**

HEADLINER® SERIES ROPE TUNED WOOD DJEMBES 1 2 3 4

- SIZES**
- S:** 8" diameter, 15 3/4" tall
 - M:** 10" diameter, 20" tall
 - L:** 12" diameter, 24" tall
 - XL:** 13" diameter, 25" tall
- PP ROPES**
- S:** 4 mm thickness, 16 runners
 - M:** 4 mm thickness, 18 runners
 - L:** 5 mm thickness, 20 runners
 - XL:** 6 mm thickness, 24 runners

1 NILE SERIES

The hand carved shells feature a gouged surface reminiscent of sun-dappled water. This texture makes the djembe easy to grip between the knees. Hand selected goat heads are secured by the traditional Mali-weave system and runners of pre-stretched nylon PP rope.

- MATERIAL** Mahogany Wood
- FEATURES** Carved from one solid piece of plantation grown Mahogany Wood
Hand selected goat heads
Pre-stretched nylon PP ropes
Hand carved shells

COLOUR Brown

2 BLACK RIVER SERIES

These Djembes are made from a solid piece of plantation grown Mahogany wood, and are hand carved with a horizontal ripple motif that suggests a flowing river. This also makes the djembe easy to grip between the knees. The hand selected goat skin head is secured and tuned with the traditional Mali Weave system.

- MATERIAL** Mahogany Wood
- FEATURES** Carved from one solid piece of plantation grown Mahogany Wood
Hand selected goat heads
Pre-stretched PP nylon ropes
Hand carved shells

COLOUR Black



CONGO SERIES

Congo Series, 13" **HDJ1-XL** Congo Series, 12" **HDJ1-L** Congo Series, 10" **HDJ1-M** Congo Series, 8" **HDJ1-S**



TRIBAL SERIES

Tribal Series, 13" **HDJ2-XL** Tribal Series, 12" **HDJ2-L** Tribal Series, 10" **HDJ2-M** Tribal Series, 8" **HDJ2-S**

3 CONGO SERIES

These djembes are carved from one solid piece of plantation grown Mahogany Wood and feature the traditional Mali Weave tuning system.

- MATERIAL** Mahogany Wood
- FEATURES** Carved from one solid piece of plantation grown Mahogany Wood
Hand selected goat heads
Pre-stretched PP nylon ropes
Hand carved shells
Ornamental carving

COLOUR Dark Brown

4 TRIBAL SERIES

The black Tribal Series are painted with an African style design and feature the traditional Mali Weave tuning system. The body is made out of one solid piece of Mahogany Wood.

- MATERIAL** Mahogany Wood
- FEATURES** Carved from one solid piece of plantation grown Mahogany Wood
Hand selected goat heads
Pre-stretched PP nylon ropes
Hand painted shells

COLOUR Black with tribal painting



PRINCE AKONGO, TOGO



ROPE TUNED WOOD DJEMBES



DONG KEXIN, CHINA



WATER RHYTHM SERIES

13", bundle with bag MDJB-M
ADJ2-XL+BAG

12", bundle with bag MDJB-M
ADJ2-L+BAG

10", bundle with bag MDJB-S
ADJ2-M+BAG

1 ORIGINAL AFRICAN STYLE ROPE TUNED WOOD DJEMBES

These djembes are carved from one solid piece of plantation grown Mahogany Wood. These high quality instruments are crafted with great attention to detail and provide an outstanding, full-volume sound. We offer these drums in three different series: The Earth Rhythm Series features a carved design in black and brown. Its earthy pattern is evocative of ploughed fields and stalks of grain. The Moon Rhythm Series features a carved design in a dark mystic finish. The Water Rhythm Series features a carved design evocative of ocean waves, and all djembes come bundled with the Professional MEINL Djembe Bag.

- SIZES**
M: 10" (9 1/4" – 10 1/4") diameter, 20" tall
L: 12" (10 3/4" – 12 1/4") diameter, 24" tall
XL: 13" (12 3/4" – 13 3/4") diameter, 25" tall
- HTP ROPES**
M: 4 mm thickness, 25 runners
L: 4 mm thickness, 35 runners
XL: 5 mm thickness, 35 runners
- MATERIAL** Mahogany Wood
- FEATURES** Carved from one solid piece of plantation grown Mahogany Wood
 Hand selected goat heads
 Pre-stretched HTP nylon ropes
 Hand carved shells
 Ornamental carving
- INCLUDES** Professional Djembe Bag made out of heavy duty padded nylon
- COLOURS**
ADJ2: Brown
ADJ3: Brown/Black
ADJ4: Black



BRYAN BROCK, USA



EARTH RHYTHM SERIES

13", bundle with bag MDJB-M
ADJ3-XL+BAG

12", bundle with bag MDJB-M
ADJ3-L+BAG

10", bundle with bag MDJB-S
ADJ3-M+BAG



MOON RHYTHM SERIES

13", bundle with bag MDJB-M
ADJ4-XL+BAG

12", bundle with bag MDJB-M
ADJ4-L+BAG

10", bundle with bag MDJB-S
ADJ4-M+BAG

2 KESSING

The Kessing is a traditional djembe accessory that provides a dry rattling accompaniment to the drum. It slides securely into the webbing and is removable.

- SIZE** Medium
- MATERIAL** Aluminum



KES-01



BOUGARABOU & PROFESSIONAL DJEMBES



Brown, 12"
ABGB-L

INTRICATE CARVING
HAND SELECTED COW HEAD



Traditional style hewn, 12"
PROADJ1-L



TRADITIONAL STYLE HEWN



"Village" carving, 12"
PROADJ2-L

SPECIAL "VILLAGE" CARVING



"African Queen" carving, 12"
PROADJ4-L

"AFRICAN QUEEN" CARVING



Deluxe carving, 14"
PROADJ3-XXL

DELUXE CARVING



TMD

PROFESSIONAL DJEMBE STAND (SEE PAGE 168)

DJEMBEFOLAS



Tiki Black, 12"
DJFS1-L

NEW!



Tiki Black, 10"
DJFS1-M

NEW!



THE HEADS OF OUR DJEMBEFOLAS ARE MADE USING THE HIGHEST GRADE HIDES AVAILABLE.

HOW WE MAKE IT

DJEMBES

1 AFRICAN BOUGARABOU

The MEINL Bougarabou is proudly made in the tradition of the Jola people of southern Senegal. The classic bougarabou features an elongated goblet-shaped body carved from Mahogany Wood. A bougarabou can be played with traditional conga or djembe techniques, and makes a rich complement within drum ensembles.

SIZE L: 12" (10 3/4" – 12 1/4") diameter, 24" tall

HTP ROPE L: 5 mm thickness, 22 runners

MATERIAL Mahogany Wood

FEATURES Carved from one solid piece of plantation grown Mahogany Wood
Hand selected cow head
Pre-stretched HTP nylon rope
Intricate carving

COLOUR Brown

2 PROFESSIONAL AFRICAN STYLE DJEMBES

The MEINL Professional African Djembes are expertly hewn from a solid piece of plantation grown Mahogany Wood, and fitted with a hand selected goatskin head. We use the traditional Mali Weave tuning system with high quality HTP rope.

MATERIAL Mahogany Wood

COLOUR Brown

2 PROFESSIONAL DJEMBE

SIZE L: 12" (10 3/4" – 12 1/4") diameter, 24" tall

HTP ROPE L: 4 mm thickness, 35 runners

FEATURES Carved from one solid piece of plantation grown Mahogany Wood
Hand selected goat heads
Pre-stretched HTP nylon rope
Traditional style hewn

3 "VILLAGE" DJEMBE

SIZE L: 12" (10 3/4" – 12 1/4") diameter, 24" tall

HTP ROPE L: 4 mm thickness, 35 runners

FEATURES Carved from one solid piece of plantation grown Mahogany Wood
Hand selected goat heads
Pre-stretched HTP nylon rope

4 "AFRICAN QUEEN" DJEMBE

SIZE L: 12" (10 3/4" – 12 1/4") diameter, 24" tall

HTP ROPE L: 4 mm thickness, 35 runners

FEATURES Carved from one solid piece of plantation grown Mahogany Wood
Hand selected goatskin head
Pre-stretched 4 mm HTP Nylon rope
Special "African Queen" carving

5 ARTISAN EDITION DJEMBE

This Djembe is hand carved from a solid plantation grown Mahogany log, and exquisitely carved with figures from the Ramayana, the epic Hindu legend and love story of Rama and Sita. Each djembe is a work of art. We make sure it sounds as good as it looks with top quality hand-selected goat skin heads, and the best pre-stretched HTP rope. We cherish our Artisan Edition Djembes as a collectors item, and so will you.

SIZE **XXL:** 14" (13 3/4" – 15 1/4") diameter, 26" tall

HTP ROPE **XXL:** 5 mm thickness, 40 runners

MATERIAL Mahogany Wood

FEATURES Carved from one solid piece of plantation grown Mahogany Wood
Hand selected goat heads
Pre-stretched HTP nylon rope
Deluxe carving

COLOUR Brown

6 DJEMBEFOLA

The MEINL Djembefola is a top-of-the line drum, carved from one solid piece of plantation grown Mahogany Wood and comes with a double rope runner tuning system. The heads of these drums are made using the highest grade hides available – selected for uniform thickness to give consistent warm tone and response. The shape of the instrument is different from other MEINL djembes and it is carved out on the inside to create the best possible sound projection.

SIZES **M:** 10" (9 1/4" – 10 1/4") diameter, 20" tall

L: 12" (10 3/4" – 12 1/4") diameter, 24" tall

HTP ROPES **M:** 4 mm thickness, 30 runners

L: 5 mm thickness, 40 runners

MATERIAL Mahogany Wood

FEATURES Carved from one solid piece of plantation grown Mahogany Wood
Highest grade goat heads
Special shape keeps the tuning longer
Carved out on the inside for better sound
Pre-stretched HTP nylon rope

COLOUR Tiki Black



ROPE TUNED FIBERGLASS DJEMBES

1



SYNTHETIC HEAD

Pharaoh's Script, 12" FADJ1-L Pharaoh's Script, 10" FADJ1-M Kenyan Quilt, 12" FADJ2-L Kenyan Quilt, 10" FADJ2-M



Natural Black, 12" FADJ5-L Natural Black, 10" FADJ5-M Earth Brown, 12" FADJ6-L Earth Brown, 10" FADJ6-M Crimson Red, 12" FADJ7-L Crimson Red, 10" FADJ7-M

1 JOURNEY SERIES ROPE TUNED FIBERGLASS DJEMBES, SYNTHETIC HEAD

The MEINL Journey Series Rope Tuned Fiberglass Djembe with synthetic head is an ultra-light weather-proof instrument that is perfect for outdoor sessions. These M.I.P.A. award winning drums convince with fat bass tones and cutting slaps.

SIZES **M:** 10" diameter, 18" tall
L: 12" diameter, 24" tall

MATERIALS Premium fiberglass
Synthetic head

FEATURES 100% synthetic are perfect for outdoor playing
Light weight fiberglass construction makes them easy to carry
Modern materials means they are unaffected by the weather
Pre-stretched PP nylon ropes

FINISHES **FADJ1:** Pharaoh's Script
FADJ2: Kenyan Quilt
FADJ5: Natural Black
FADJ6: Earth Brown
FADJ7: Crimson Red



SHYAM EDWANKAR, INDIA

2



HAND SELECTED GOAT HEAD

Pharaoh's Script, 12" FADJ1-L-G Pharaoh's Script, 10" FADJ1-M-G Kenyan Quilt, 12" FADJ2-L-G Kenyan Quilt, 10" FADJ2-M-G



Natural Black, 12" FADJ5-L-G Natural Black, 10" FADJ5-M-G Earth Brown, 12" FADJ6-L-G Earth Brown, 10" FADJ6-M-G Crimson Red, 12" FADJ7-L-G Crimson Red, 10" FADJ7-M-G

2 JOURNEY SERIES ROPE TUNED FIBERGLASS DJEMBES, GOAT HEAD

The MEINL Journey Series Rope Tuned Fiberglass Djembe with hand selected goat head is the perfect instrument for drum circles due to their light weight but durable construction. The goat head produces warm bass tones and cutting slaps.

SIZES **M:** 10" diameter, 18" tall
L: 12" diameter, 24" tall

MATERIALS Premium fiberglass
Hand selected goat head

FEATURES Goat heads for warm tones
Light weight fiberglass construction makes them easy to carry
Pre-stretched PP nylon ropes

FINISHES **FADJ1:** Pharaoh's Script
FADJ2: Kenyan Quilt
FADJ5: Natural Black
FADJ6: Earth Brown
FADJ7: Crimson Red



STDJST-BK

TRAVEL DJEMBE STAND (SEE PAGE 168)



Pharaoh's Script, 12" **FMDJ1-L-F** Pharaoh's Script, 10" **FMDJ1-M-F** Kenyan Quilt, 12" **FMDJ2-L-F** Kenyan Quilt, 10" **FMDJ2-M-F**



Natural Black, 12" **FMDJ5-L-F** Natural Black, 10" **FMDJ5-M-F** Earth Brown, 12" **FMDJ6-L-F** Earth Brown, 10" **FMDJ6-M-F** Crimson Red, 12" **FMDJ7-L-F** Crimson Red, 10" **FMDJ7-M-F**

1 MECHANICAL TUNED FIBERGLASS DJEMBES, SYNTHETIC HEAD
 Perfect for outdoors, these light-weight instruments feature a mechanical tuning system with a synthetic head. The mechanical tuning allows for easy and quick tuning. These djembes are perfect for any outdoor conditions.
SIZES **M:** 10" diameter, 18" tall
L: 12" diameter, 24" tall
MATERIALS Premium fiberglass
 Synthetic Head
FEATURES 100% synthetic are perfect for outdoor playing
 Traditional Rim
 Black powder coated hardware
 Light-weight and durable construction

FINISHES **FMDJ1:** Pharaoh's Script
FMDJ2: Kenyan Quilt
FMDJ5: Natural Black
FMDJ6: Earth Brown
FMDJ7: Crimson Red



Pharaoh's Script, 12" **FMDJ1-L-G** Pharaoh's Script, 10" **FMDJ1-M-G** Kenyan Quilt, 12" **FMDJ2-L-G** Kenyan Quilt, 10" **FMDJ2-M-G**



Natural Black, 12" **FMDJ5-L-G** Natural Black, 10" **FMDJ5-M-G** Earth Brown, 12" **FMDJ6-L-G** Earth Brown, 10" **FMDJ6-M-G** Crimson Red, 12" **FMDJ7-L-G** Crimson Red, 10" **FMDJ7-M-G**

2 MECHANICAL TUNED FIBERGLASS DJEMBE, GOAT HEAD
 These light-weight instruments feature a mechanical tuning system with a goat head. The mechanical tuning allows for easy and quick tuning. The hand selected goat head produces warm fat bass and rich open tones.
SIZES **M:** 10" diameter, 18" tall
L: 12" diameter, 24" tall
MATERIALS Premium fiberglass
 Hand selected goat head
FEATURES Goat heads for warm tones
 Traditional Rim
 Black powder coated hardware
 Light-weight and durable construction

FINISHES **FMDJ1:** Pharaoh's Script
FMDJ2: Kenyan Quilt
FMDJ5: Natural Black
FMDJ6: Earth Brown
FMDJ7: Crimson Red



MCR-BK

OUR CONGA RISERS CAN ALSO BE USED FOR DJEMBES (SEE PAGE 023)



PROFESSIONAL FIBERGLASS DJEMBES



MOUNTING THE HEAD WITH TOP QUALITY PRE-STRETCHED HTP NYLON ROPE.

HOW WE MAKE IT

NEW!

NEW!



Phantom Black, 12"
PROFADJ1-L



Phantom Black, 10"
PROFADJ1-M

PROFESSIONAL FIBERGLASS DJEMBES

The MEINL Professional Fiberglass Djembes come in a special designed shape. Equipped with synthetic head, this the perfect drum for outdoor gigs. These drums feature a lip positioned on the base to prevent the ring from slipping – this also helps to keep the djembe in tune for longer.

SIZES **M:** 10" diameter, 20" tall
L: 12" diameter, 24" tall

HTP ROPES **M:** 4 mm thickness, 25 runners
L: 5 mm thickness, 30 runners

MATERIALS Premium fiberglass
Synthetic head

FEATURES 100% synthetic are perfect for outdoor playing

Lightweight fiberglass construction
Pre-stretched HTP nylon ropes

COLOUR Phantom Black, matte



SYNTHETIC HEAD

HEADLINER® SERIES DANCING PERCUSSION



YOEL PAEZ, SPAIN

1



Red, 8" x 11 1/4"
HFDD2R

2



Red, 8" x 11 1/3"
HDJ200R

3



Black, 8 1/2" x 24"
HC301BK

4



Red, 12" x 22 3/4"
HDJ400R

5



MDJS1

ADJUSTABLE STRAPS

The MEINL Headliner® Series Dancing Percussion are the perfect instruments for educational or street percussion. They are made from high quality materials and produce great sounds.

1 FIBERGLASS FAMILY DRUM

SIZE 8" diameter, 11 1/4" tall

MATERIAL Premium fiberglass

FEATURES Traditional rim
Black powder coated hardware

INCLUDES Nylon strap
Tuningkey

COLOUR **R:** Red

2 FIBERGLASS MINI DANCING DJEMBE

SIZE 8" diameter, 11 1/3" tall

MATERIAL Premium fiberglass

FEATURES Traditional rim
Black powder coated hardware
Floatune Tuning System

INCLUDES Nylon strap
Tuning key

COLOUR **R:** Red

3 FIBERGLASS DANCING CONGA

SIZE 8 1/2" diameter, 24" tall

MATERIAL Premium fiberglass

FEATURES 7 mm strong tuning lugs
2.2 mm rounded rim
Black powder coated hardware

INCLUDES Nylon strap
Tuning key

COLOUR **BK:** Black

4 FIBERGLASS DANCING DJEMBE

SIZE 12" diameter, 22 3/4" tall

MATERIAL Premium fiberglass

FEATURES 7 mm strong tuning lugs
2.2 mm rounded rim
Black powder coated hardware

INCLUDES Nylon strap
Tuning key

COLOUR **R:** Red

5 PROFESSIONAL DJEMBE STRAP

The MEINL Djembe Strap comfortably and securely holds any djembe in the perfect playing position.

MATERIAL Cloth-covered nylon

FEATURES Quick change hook
Adjustable straps
Quick-release buckles

COLOUR Multi colour



WOOD & FLOATUNE DJEMBES

NEW! NEW! NEW!



Vintage Wine Barrel, 12 1/2"
HDJ500VWB-M

Wine Red Burst, 12 1/2"
HDJ500WRB

Vintage Sunburst, 12 1/2"
HDJ500VSB

Natural, 12 1/2"
HDJ500NT



Blue Sparkle, 12"
DJF3BSP

Red Sparkle, 12"
DJF3RSP

Zebra Finished Ash, 12"
DJW3ZFA-M



Gold Amber Sunburst, 12 3/4"
DJW2GAB-M

Gold Amber Sunburst, 12"
DJW3GAB-M

REPOSITIONED TUNING LUGS
OFFER PERFECT PLAYING COMFORT



NEBOJISA JOVAN ZIVKOVIC, GERMANY



Natural, 12 3/4"
DJW2NT

Natural, 12"
DJW3NT

African Brown, 12 3/4"
DJW2AB-M

African Brown, 12"
DJW3AB-M

FLOATUNE TUNING AVOIDS THE
NEED TO DRILL THROUGH THE SHELL

1 HEADLINER® SERIES WOOD DJEMBES

The MEINL Headliner® Series Djembes have it all! Equipped with hand selected goat heads, they produce the classic djembe sounds reaching from fat basses to rich open tones and cutting slaps.

SIZE 12 1/2" diameter, 25 1/4" tall

MATERIAL Rubber Wood
(*Hevea brasiliensis* Muell.-Arg.)

FEATURES 8 mm strong tuning lugs
2 mm rounded rims
Original MEINL style tuning brackets
Black powder coated hardware
Hand selected goat heads
Sleek Hourglass shape for more comfort

INCLUDES Tuning key

COLOURS **NT:** Natural, high gloss

VSB: Vintage Sunburst, high gloss

VWB-M: Vintage Wine Barrel, matte

WRB: Wine Red Burst, high gloss

2 FLOATUNE SERIES FIBERGLASS DJEMBES

The MEINL Floatune Series Fiberglass Djembes are truly a sound alternative. Fiberglass has enormous strength and can produce slaps of outstanding clarity and immensely powerful bass tones.

SIZE 12" diameter, 24 1/4" tall

MATERIAL Premium fiberglass

FEATURES True Skin Goat Heads

8 mm strong tuning lugs

3 mm rounded SSR-Rims

Easy tuning and comfortable

change of heads

Rubber pads and lug placement

offer perfect playing comfort

Floatune Tuning System

Chrome plated hardware

INCLUDES Accessory pouch

L-shaped tuning key

Tune Up Oil

COLOURS **BSP:** Blue Sparkle

RSP: Red Sparkle

FLOATUNE SERIES WOOD DJEMBES 3 4

The MEINL Floatune Djembes are modelled after the West African originals. Deep, round-sounding bass notes complimented by crisp tones and slaps are produced by this drum.

FEATURES True Skin Goat Heads

8 mm strong tuning lugs

3 mm rounded SSR-Rims

Easy tuning and comfortable

change of heads

Rubber pads and lug placement offer

perfect playing comfort

Floatune Tuning System

Chrome plated hardware

INCLUDES Accessory pouch

L-shaped tuning key

Tune Up Oil

COLOURS **AB-M:** African Brown, matte

GAB-M: Gold Amber Sunburst, matte

NT: Natural, high gloss

ZFA-M: Zebra Finished Ash, matte

3 FLOATUNE SERIES WOODCRAFT DJEMBE

SIZE 12" diameter, 24 1/4" tall

MATERIAL American White Ash

(*Fraxinus americana* L.)

4 FLOATUNE SERIES WOOD DJEMBES

SIZES **DJW2:** 12 3/4" diameter, 25 1/4" tall

DJW3: 12" diameter, 24 1/4" tall

MATERIAL Rubber Wood

(*Hevea brasiliensis* Muell.-Arg.)



ST-DJEMBE

STEELY II DJEMBE STAND (SEE PAGE 168)



DARBUKAS DOUMBEKS



01 Aluminum is molten in a crucible, ready for casting.

02 These aluminum blanks will be spun into darbuka bodies.

03 Darbuka body is here spun-formed on a lathe.

04 Molten aluminum is cast into a form.

05 Cast aluminum bodies and rims.

06 Rim is getting finished after casting.

07 Some designs are hammered by hand.

08 Some designs are engraved by mechanical burin.

1



8" x 14 1/2" **HE-104** 7 1/4" x 13 1/3" **HE-103** 6 1/2" x 12 3/4" **HE-102** 5 7/8" x 11" **HE-101** 5 1/3" x 9 1/4" **HE-100**

2

NEW! NEW! NEW!



8" x 14 1/2" **HE-114** 7 1/4" x 13 1/3" **HE-113** 6 1/2" x 12 3/4" **HE-112** 5 7/8" x 11" **HE-111** 5 1/3" x 9 1/4" **HE-110**

DARBUKAS

MEINL darbukas are made in the tradition of the original, esoteric goblet-shaped drums found in music from Eastern Europe, the Middle East and Southern Asia. Our darbukas are constructed from thin shells in various metals, each metal giving the different models their special timbre. The head is secured and tuned with external rings set close to the shell, in the Turkish-style. Light yet powerful, the darbukas have a deep full bass. They are well suited for high-pitched snapping sounds as well as a wide range of articulated "dum" and "tak" strokes.

1 ALUMINUM DARBUKAS, PLAIN

SIZES **HE-100:** 5 1/3" x 9 1/4"
HE-101: 5 7/8" x 11"
HE-102: 6 1/2" x 12 3/4"
HE-103: 7 1/4" x 13 1/3"
HE-104: 8" x 14 1/2"
MATERIAL Aluminum
FEATURE Synthetic heads
INCLUDES Tuning key

2 ALUMINUM DARBUKAS, HAND-HAMMERED

SIZES **HE-110:** 5 1/3" x 9 1/4"
HE-111: 5 7/8" x 11"
HE-112: 6 1/2" x 12 3/4"
HE-113: 7 1/4" x 13 1/3"
HE-114: 8" x 14 1/2"
MATERIAL Aluminum
FEATURES Synthetic heads
Hand-hammered shells
INCLUDES Tuning key

3



8 1/4" x 16" **HE-315** 8" x 14 1/2" **HE-314**

4



8" x 14 1/2" **HE-124** 6 1/2" x 12 3/4" **HE-122**

5



7 7/8" x 15 1/2" **HE-215** 7 1/2" x 14 3/4" **HE-214**

6



7 7/8" x 15 1/2" **HE-205** 7 1/2" x 14 3/4" **HE-204**

3 ALUMINUM JINGLE DARBUKAS, HAND-HAMMERED

SIZES **HE-314:** 8" x 14 1/2"
HE-315: 8 1/4" x 16"
MATERIAL Aluminum
FEATURES Built in jingles
Synthetic heads
Hand-hammered shells
INCLUDES Tuning key

4 ALUMINUM DARBUKAS, HAND-ENGRAVED

SIZES **HE-122:** 6 1/2" x 12 3/4"
HE-124: 8" x 14 1/2"
MATERIAL Aluminum
FEATURES Synthetic heads
Hand engraved shells
INCLUDES Tuning key

5 COPPER DARBUKAS, BRASS PLATED, HAND-HAMMERED

SIZES **HE-214:** 7 1/2" x 14 3/4"
HE-215: 7 7/8" x 15 1/2"
MATERIAL Copper
FEATURES Synthetic heads
Hand-hammered shells
INCLUDES Carrying bag
Spare head
Tuning key

6 COPPER DARBUKAS, HAND ENGRAVED

SIZES **HE-204:** 7 1/2" x 14 3/4"
HE-205: 7 7/8" x 15 1/2"
MATERIAL Copper
FEATURES Natural rawhides
Hand engraved shells
INCLUDES Carrying bag
Spare head
Tuning key



1



PREMIUM FIBERGLASS



8 1/2" x 17 1/8"
FDB3000G

2



BLACK



COPPER

8 1/2" x 17 1/8"
HE-3000

8 1/2" x 17 1/8"
HE-3020



ELLEN MAYER, GERMANY

3



HAND ENGRAVED SHELL

8 1/2" x 17 1/8"
HE-3018

4



HAND-HAMMERED SHELL

8 1/2" x 17 1/8"
HE-3030

5



WOOD COVERED SHELL

8 1/2" x 17 1/8"
HE-3400

6



HAND ENGRAVED SHELL

8 1/2" x 17 1/8"
HE-3012



PROFESSIONAL DOUMBEK STAND
(SEE PAGE 169)

TMID

1 FIBERGLASS DOUMBEK

Our Fiberglass Doumbek has great sound properties and modern construction. Durable premium fiberglass shell bestows resonance and clarity. Crosshatched shell texture makes the doumbek easy to hold and resists slipping. Synthetic head holds tuning in all weather conditions.

SIZE 8 1/2" x 17 1/8"

MATERIAL Premium fiberglass

FEATURES Solid fiberglass construction
Synthetic head

COLOUR **G:** Gold

DOUMBEKS 2 3 4 5 6

SIZE 8 1/2" x 17 1/8"

INCLUDES Carrying bag, Spare head, Tuning key

2 ALUMINUM DOUMBEKS

Hand made entirely of aluminum, the MEINL Doumbek is outstanding in sound and quality, reaching from resonant lows to ringing highs. Available in two different finishes.

MATERIAL Aluminum

FEATURE Synthetic heads

COLOURS **HE-3000:** Black

HE-3020: Copper

3 ALUMINUM DOUMBEK, HAND ENGRAVED

This aluminum doumbek comes in a ornamental hand engraving and produces snappy mid east sounds.

MATERIAL Aluminum

FEATURES Synthetic head

Hand engraved shell

4 ALUMINUM DOUMBEK, HAND-HAMMERED

The aluminum shell of this MEINL Doumbek is completely hand-hammered for a most appealing look.

MATERIAL Aluminum

FEATURES Synthetic head

Hand-hammered shell

5 ALUMINUM DOUMBEK, WOOD COVERED

The shell of this MEINL Doumbek is made from aluminum and is completely covered with a layer of the finest wood.

MATERIAL Aluminum

FEATURES Synthetic head

Wood covered shell

6 COPPER DOUMBEK, HAND ENGRAVED

The copper shell of this MEINL Doumbek is hand engraved for a stunning look. A very traditionally looking and sounding instrument.

MATERIAL Copper

FEATURES Synthetic head

Hand engraved shell



RÜDIGER MAUL, GERMANY



HOW WE MAKE IT

ARTISAN EDITION DOUMBEEKS

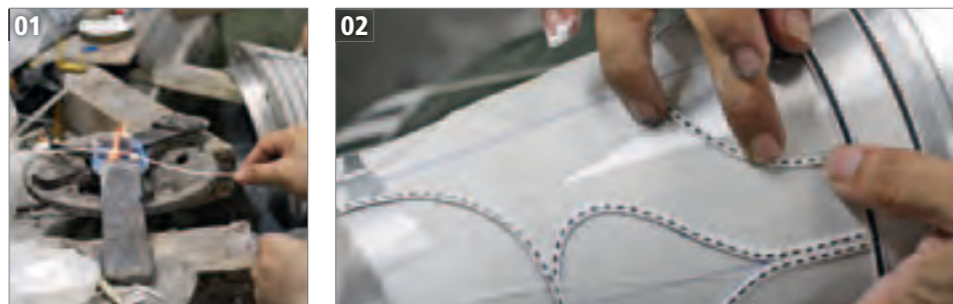

- 01 Heating the inlays for the base design.
- 02 Gluing the inlays on the body.
- 03 Mother of Pearl is used to cover the aluminum shell.
- 04 Cutting Mother of Pearl in small pieces.
- 05 Preparing a special glue for the Mother of Pearl mosaic.
- 06 Applying the Mother of Pearl pieces on the drum.
- 07 Sanding the shell to make it smooth and shiny.

ARTISAN EDITION DOUMBEEKS

1 NEW!



Palace Mosaic, 8 3/4" x 17 1/2"
AE-ED5-1

3 NEW!



9" x 18 1/2"
AE-ED-SB



2 NEW!



Mosaic Royale, 8 3/4" x 17 1/2"
AE-ED5-2

4 NEW!



9" x 18 1/2"
AE-ED7

ARTISAN EDITION DOUMBEEKS

The new Artisan Edition Doumbeks by Meinl are made in Egypt. The authentic mosaic artwork finish is created with mother of pearl inlays. The doumbek itself is cast of solid aluminum and has a quality heft and beautiful tone that serious players will love.

1 2 SAMAI LINE

- MATERIALS** Aluminum body
Mother of pearl
- SIZE** 8 3/4" x 17 1/2"
- WEIGHT** 4.7kg
- FEATURES** Well balanced shape
Authentic Egyptian mosaic inlays
Produces outstanding dums and taks (teks)
- INCLUDES** Nylon bag
Spare head
Tuning key

3 ARTIST SERIES (SUAT BORAZAN)

The MEINL team is happy to have teamed with Suat Borazan to produce a well balanced drum that produces deep dums and sharp taks (teks). This Artist Series Doumbek is a versatile drum that meets the demands and specifications of all professional doumbek players.

- MATERIALS** Aluminum body
Mother of pearl
- SIZE** 9" x 18 1/2"
- WEIGHT** 5.7kg
- FEATURES** Extra heavy for better control
Larger in diameter for more projection
Well balanced shape
Authentic Egyptian mosaic inlays
Produces outstanding dums and taks (teks)
- INCLUDES** Nylon bag
Spare head
Tuning key

4 EL ZAFFA LINE

- MATERIALS** Aluminum body
Mother of pearl
Wood inlays
- SIZE** 9" x 18 1/2"
- WEIGHT** 5.7kg
- FEATURES** Extra heavy for better control
Larger in diameter for more projection
Well balanced shape
Authentic Egyptian mosaic inlays
Produces outstanding dums and taks (teks)
- INCLUDES** Nylon bag
Spare head
Tuning key

DOUMBEEKS

TABLAS

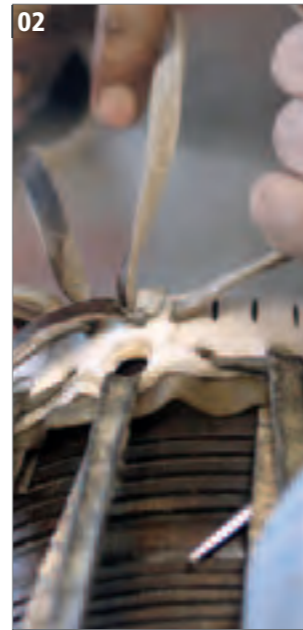

- 01 Preparing the head.
- 02 Mounting the head .
- 03 Preparing the syahi from different ingredients.
- 04 Making it look nice by using different kind of raw hides.
- 05 Putting the syahi on the dayan.
- 06 Cutting spare material of the damping layer.

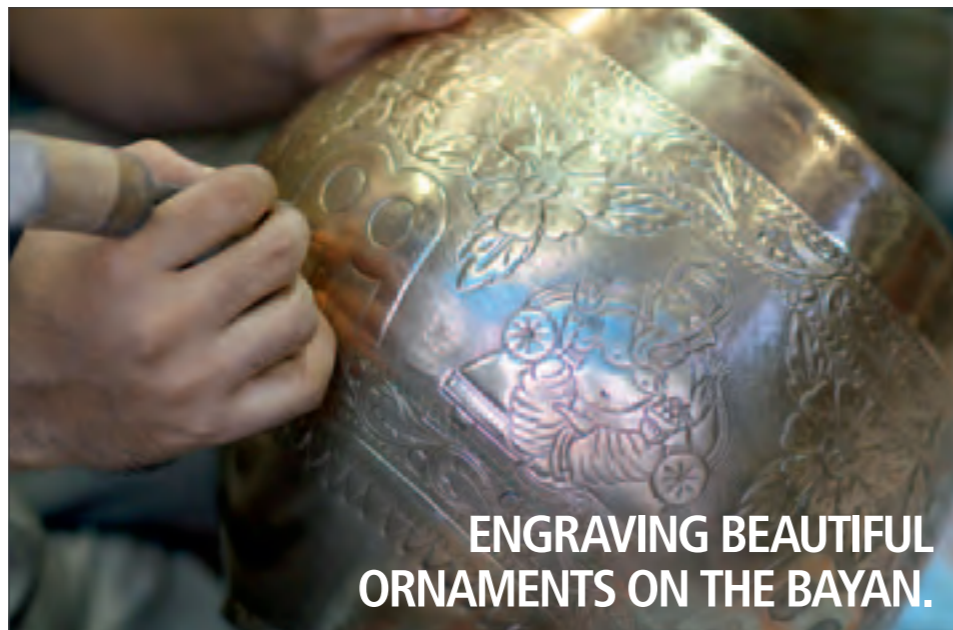

ENGRAVING BEAUTIFUL ORNAMENTS ON THE BAYAN.

TABLAS



Bayan, 8 1/2" & Dayan, 5 1/2"
TABLA

Bayan, 9" & Dayan, 5 1/2"
PRO-TABLA

1 TABLA SET

The MEINL Tabla is made in the time-honored Indian tradition. Proper tuning is achieved by adjusting wooden rollers that are fitted under the nylon verticals.

SIZES Dayan 5 1/2"
Bayan 8 1/2"

MATERIALS Chrome plated copper with goat skin
Rosewood with goat skin

FEATURES Authentic tabla heads
Nylon straps for longer durability

INCLUDES Padded support rings
Tuning hammer

2 ARTISAN EDITION TABLAS

A top-of-the-line professional quality tabla set. Our Artisan Edition Tablas are made according to their classical heritage, and are superbly crafted. The tones are unsurpassed for their clarity and character. These are tablas that will make any player proud.

SIZES Dayan 5 1/2"
Bayan 9"

MATERIALS Copper with goat skin
Mahogany with goat skin

FEATURES Top quality goat skin tabla heads
Traditional tuning system with rawhide thongs

INCLUDES Tuning hammer and wooden tuning dowel
Ring pads
Protective head covers



MUTHU KUMAR, INDIA

TOP-OF-THE-LINE PROFESSIONAL TABLA SET!
MADE BY A MASTER CRAFTSMAN IN INDIA

1



Iya, 6 3/4"
BA3BK

Itotele, 5 3/4"
BA2BK

Okonkolo, 5 1/4"
BA1BK



ALFONSO GARRIDO, GERMANY

2



9" x 20"
ATD-XL

8" x 16"
ATD-L

7" x 12"
ATD-M



COMES WITH A CURVED WOODEN BEATER

3



BE1R



1



Jumbo
SH2VSB

Medium
SH1BK

Medium
SH-R

NEARLY UNBREAKABLE

2



11"
MTA1SNT-M



TRUE SKIN BUFFALO HEADS

3



8" & 9"
HCG89NT

HEAVY DUTY STAND CAN BE TILTED

4



7"
RAMWONG7

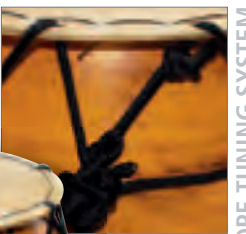

TRADITIONAL ROPE TUNING SYSTEM

1 BATAS

The MEINL Batas are made from premium fiberglass for more durability, lighter weight and comfortable playing, and have a traditionally authentic sound.

SIZES Okonkolo 5 1/4" & 8",
Itotele 5 3/4" & 8 3/4"
Iya 6 3/4" & 12"

MATERIAL Premium fiberglass

FEATURES Hand selected buffalo heads
Traditional TTR-Rims

INCLUDES Nylon strap
Tuning key

COLOUR **BK:** Black

2 AFRICAN WOOD TALKING DRUMS

Our African Talking Drums are carved into an hour-glass shape from a solid piece of Mahogany wood, and decorated with a carved motif. Two hand-selected goatskin heads are spanned with high-quality nylon rope.

SIZES **M:** 7" x 12", 23 rope runners, 3 mm PP rope
L: 8" x 16", 28 rope runners, 3 mm PP rope
XL: 9" x 20", 34 rope runners, 3 mm PP rope

MATERIALS Mahogany Wood
Hand selected goat heads

FEATURES Carved from one solid piece of plantation grown Mahogany Wood
Nylon tuning strap

INCLUDES Curved wooden beater

FINISH Brown/Black

3 BERIMBAU

The thin striker and a caxixi are held in the right hand, while the left hand supports the bow and modulates the string with a small metal disc. The whole instrument is moved off-and-on the abdomen, opening and closing the resonant gourd, for a captivating "wah-wah" effect.

MATERIAL Premium fiberglass

INCLUDES Small Caxixi
Metal plate
Wooden stick
Carrying bag

COLOUR **R:** Red

1 SHEKERES

MEINL shekeres are handmade from premium fiberglass and fitted with a net of beads.

SIZES **SH-R:** Medium
SH1BK: Medium
SH2VSB: Jumbo

MATERIAL Premium fiberglass

COLOURS **BK:** Black
VSB: Vintage Sunburst
R: Red

2 TAMBORA

The rhythm of the Merengue has its roots in the Dominican Republic where the use of a Tambora drum is essential in creating this style of music.

SIZE 11"
MATERIAL Rubber Wood
(*Hevea brasiliensis* Muell.-Arg.)

FEATURES True Skin Buffalo Heads
Black powder coated hardware

INCLUDES Nylon strap
Wooden beaters
Tuning key

COLOUR **SNT-M:** Super Natural

FINISH Matte

3 WOOD CONGUITAS

The Conguitas complements the congas in a harmonically supportive sound spectrum.

SIZES 8" & 9"
MATERIAL Rubber Wood
(*Hevea brasiliensis* Muell.-Arg.)

FEATURES 8 mm strong tuning lugs
Original MEINL style tuning brackets
Traditional rims
Black powder coated hardware

Hand selected buffalo heads

INCLUDES Height adjustable tilting double braced tripod stand
Wooden beaters
Tuning key
Wrench

COLOUR **NT:** Natural

FINISH High gloss

4 RAMWONG

Ramwong is a Thai folk dance which evolved from Ramthone.

SIZE 7" diameter, 10" tall
MATERIAL Wood
FEATURES Natural rawhide
Traditional rope tuning system

1 NEW!



ID10WH



IBO HOLDER (SEE PAGE 172)

TMIH



LUIS RIBEIRO, AUSTRIA



ID2BKR



ID1BKR

BUILT IN MICROPHONE HOLE

1 QUINTO IBO DRUM
This ceramic Ibo Drum is small in size but big in sound. Perfect for unplugged gigs.
SIZE Small
MATERIAL Ceramic
FEATURES Full and rich sounds
Built in microphone hole
COLOUR **WH:** White

2 FIBERGLASS IBO DRUM, LONG NECK
The Fiberglass Ibo Drum with long neck has a wide variety of different sounds and is nearly unbreakable.
SIZE Long neck
MATERIAL Premium fiberglass
FEATURES Built in microphone hole
Resistant shell construction
INCLUDES Foam padded base
COLOUR **BKR:** Black/Red

3 FIBERGLASS IBO DRUM
This Ibo Drum has a wide variety of different sounds and the fiberglass body makes it nearly unbreakable.
SIZE Large
MATERIAL Premium fiberglass
FEATURES Built in microphone hole
Resistant shell construction
INCLUDES Foam padded base
COLOUR **BKR:** Black/Red

4 HEADED FIBERGLASS TRI SOUND IBO DRUM
This unique Ibo Drum features an additional rawhide playing surface and an extra thin bottom for enhanced sound.
SIZE Large
MATERIAL Premium fiberglass

FEATURES Rawhide playing surface
Built in microphone hole
Resistant shell construction
INCLUDES Foam padded base
COLOUR **GO:** Gold Ornament

5 FIBERGLASS TRI SOUND IBO DRUM
The regular Tri Sound Ibo Drum features an additional fiberglass playing surface and an extra thin bottom.
SIZE Large
MATERIAL Premium fiberglass
FEATURES Extra fiberglass playing surface
Built in microphone hole
Resistant shell construction
INCLUDES Foam padded base
COLOUR **BKO:** Black Ornament



ID3GO

RAWHIDE PLAYING SURFACE



ID4BKO

EXTRA FIBERGLASS PLAYING SURFACE



ID6

HAND CARVED BODY



ID7RB



ID8RB

EXTRA FIBERGLASS BOTTOM FOR MORE SOUND OPTIONS



ID9BK/WH

THE FIBERGLASS LIQUID IBO DRUM IS FILLED WITH WATER

6 WOOD IBO DRUM
The wooden body ensures a wide sonic range.
SIZE Large
MATERIAL Made from Mango Wood (*Mangifera* Sp.L.)
FEATURES Dry tones
Built in microphone hole
INCLUDES Foam padded base

7 CERAMIC IBO DRUM
The ceramic body of this Ibo Drum causes a slight enhancement of the higher frequencies, with fat and powerful bass tones.
SIZE Large
MATERIAL Ceramic
FEATURES Full and rich sounds
Built in microphone hole
INCLUDES Foam padded base
COLOUR **RB:** Red/Brown

8 CERAMIC IBO DRUM, FIBERGLASS BOTTOM
The special feature of this MEINL Ceramic Ibo Drum is the fiberglass bottom for extra sound options.
SIZE Large
MATERIAL Ceramic
FEATURES Fiberglass playing surface
Built in microphone hole
INCLUDES Foam padded base
COLOUR **RB:** Red/Brown

9 FIBERGLASS LIQUID IBO DRUM
A sealed metal chamber containing water is permanently bonded to the premium fiberglass body. The liquid chamber adds fluctuating overtones to the drum's fundamentals.
SIZE Large
MATERIAL Premium fiberglass
FEATURES Special bottom, filled with water
Built-in microphone hole
Resistant shell construction
INCLUDES Foam padded base
COLOUR **BK/WH:** Black/White





CAJONS

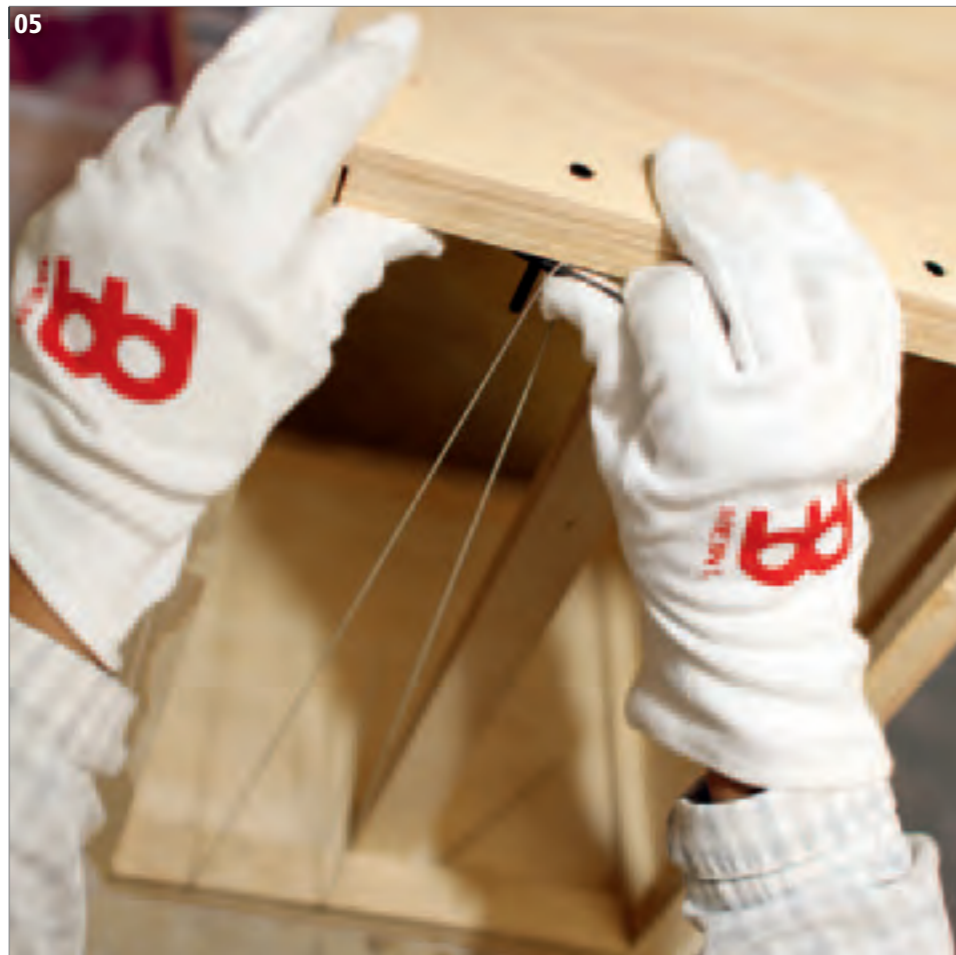
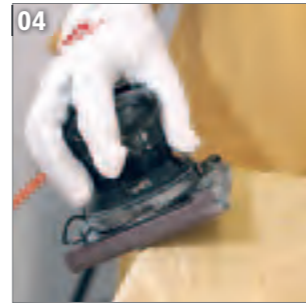
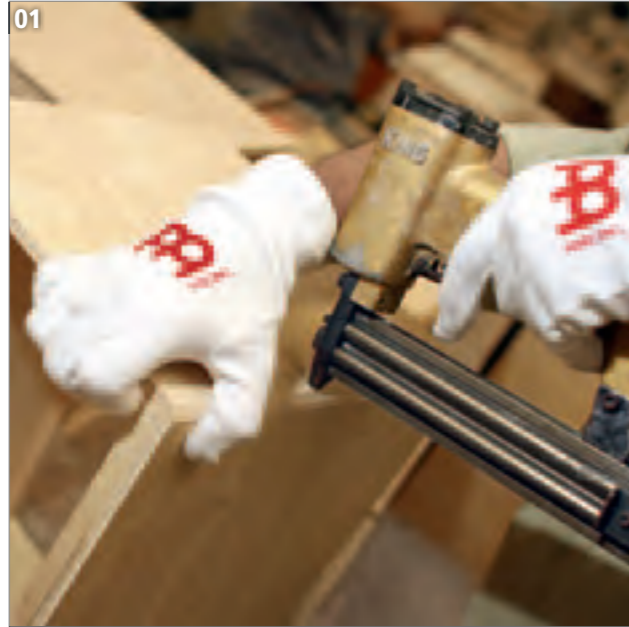

01 MEINL cajons are constructed with a combination of gluing and nailing techniques.

02 The cajon body is planed by hand. This creates the optimal contact between the faceplate and the body.

03 The sound hole is cut out of the back plate.

04 The sides and edges are carefully sanded.

05 The adjustable sizzle strings are positioned behind the frontplate. Here you see the tuning screws on the bottom of the cajon.

06 Our proprietary snare mechanism with foot pedal is being installed. Here you see the return spring being connected.

07 Here you see a Bubinga faceplate being fastened with screws.

08 MEINL cajons are securely packed for safe transport to distributors and dealers all over the world.



THE PARTS ARE MEASURED AND MARKED FOR DRILLING.



MEINL HEADLINER® SERIES CAJONS



1 HEADLINER® SERIES CAJONS

The MEINL Headliner® Series Cajons deliver the classic cajon sound at an affordable price and can be used in Flamenco or World Music. They are also very useful during unplugged gigs for delivering the rhythmic foundation for a whole band when a full drum set can't be used.

SIZES
HCAJ1: 11 3/4" W x 18" H x 11 3/4" D
HCAJ3: 11 3/4" W x 19 3/4" H x 11 3/4" D
HCAJ5: 13 1/4" W x 19 3/4" H x 13 3/4" D

MATERIALS **HCAJ1AWA / HCAJ3AWA / HCAJ5AWA**
 Frontplate: Stained American White Ash (*Fraxinus Americana* L.)
 Resonating body: Eco-friendly medium density fiberboard

FEATURES

Adjustable top corners
 Adjustable sizzle effect
 Anti-slip sitting surface
 Wide sound options
HCAJ5: Full bass spectrum

INCLUDES Allen wrench
FINISH Matte

HCAJ1MH-M / HCAJ3MH-M / HCAJ5MH-M

Frontplate: Mahogany
 Resonating body: Rubber Wood (*Hevea brasiliensis* Muell.-Arg.)

HCAJ1NT / HCAJ3NT / HCAJ5NT

Frontplate: Rubber Wood (*Hevea brasiliensis* Muell.-Arg.)
 Resonating body: Rubber Wood (*Hevea brasiliensis* Muell.-Arg.)



ADJUSTABLE SIZZLE EFFECT

ANTI-SLIP SITTING SURFACE

2 CAJON PAD

The MEINL Cajon Pad is the optimal cushion for our Headliner® Series Cajons. It assures more comfort and a safe seat while playing the instrument.

SIZE 10" x 10"
MATERIAL Soft foam

2



CAJ-PAD



HEAVY DUTY RUBBER FEET FOR A SOLID BASE

ADJUSTABLE TOP CORNERS



STEPHAN MAASS, GERMANY

1



Makah-Burl
CAJ3MB-M



Black Makah-Burl
CAJ3BMB-M



Premium fiberglass
CAJ7NT-BK



American White Ash
CAJ3AWA

ADJUSTABLE TOP CORNERS



JOANNIE LABELLE, CANADA

2



Bundle with MSTCJB
CAJ3MB-M+BAG



Bundle with MSTCJB
CAJ3BMB-M+BAG



Bundle with MSTCJB
CAJ7NT-BK+BAG

BUNDLED WITH BAG



TMCAJ

PROFESSIONAL CAJON STAND (SEE PAGE 168)

3



Bubinga
CAJ300BU-M



ERGO-SHAPE (PATENTED)

1 STRING CAJONS (US PATENT)

MEINL Cajons feature a built in adjustable sizzle effect. Strings, which touch the frontplate on the inside and span from top to bottom, deliver a sensitive rattle that can be adjusted to fit various musical applications. The patented integrated string mute system controls the tension of the strings and ensures a dry and crisp sizzle effect.

MATERIALS Resonating body: Rubber Wood (*Hevea brasiliensis* Muell.-Arg.),

CAJ3MB-M

Frontplate: Makah-Burl

CAJ3BMB-M

Frontplate: Black Makah-Burl

CAJ7NT-BK

Frontplate: Premium fiberglass

FEATURES

- Adjustable top corners
- Adjustable sizzle effect
- Integrated string mute system (US patent)
- Wide sound options
- Padded sitting surface

INCLUDES

Allen wrench

FINISH

Matte



ADJUSTABLE SIZZLE EFFECT WITH INTEGRATED STRING MUTE SYSTEM (US PATENT)

2 STRING CAJONS BUNDLE WITH BAG (US PATENT)

3 ERGO-SHAPE STRING CAJON (PATENTED)

The MEINL Ergo-Shape String Cajon features an exotic Bubinga frontplate and two innovations: The frontplate is ergonomically curved for maximum comfort and sound development, and the string mute system gives your sound extra precision and control. The Bubinga frontplate is a rich and beautiful reddish coloured African wood.

MATERIALS Frontplate: Bubinga

Resonating Body: Rubber Wood (*Hevea brasiliensis* Muell.-Arg.)

FEATURES

- Ergo-Shape (DE, US patent)
- Adjustable sizzle effect
- Integrated string mute system (US patent)
- Adjustable top corners
- Padded sitting surface

INCLUDES

Allen wrench

FINISH

Matte



ALEX PERTOUT, AUSTRALIA



SNARE, COLLECTION & TURBO CAJONS



1 SNARE CAJONS

The snares touch the frontplate from the inside and deliver the classical cajon sound, which is requisite in Flamenco music. A knurled knob adjusts the amount of pressure used to press the snare wires against the frontplate.

MATERIALS CAJ1CA-M

Frontplate: Premium fiberglass
Resonating body: Rubber Wood (*Hevea brasiliensis* Muell.-Arg.)
CAJ1EB-M
Frontplate: Ebony
Resonating body: Rubber Wood (*Hevea brasiliensis* Muell.-Arg.)
CAJ1SNT-M
Frontplate: American White Ash (*Fraxinus americana* L.)

FEATURES

Adjustable top corners
Internal, adjustable snare wires
Padded sitting surface
Wide sound options

FINISH

Matte

2 COLLECTION CAJON

The MEINL Collection Cajon features elegant veneers, both for the frontplate, and for the resonating body.

MATERIALS

Frontplate: Cherry
Resonating body: Red Oak (*Quercus rubra*)
Adjustable top corners
Internal, adjustable snare wires
Padded sitting surface

FINISH

Matte

3 TURBO CAJON (US PATENT)

Our Turbo Cajon goes an extra step towards cutting edge. We made this cajon with upper corners that have deeply cut channels with castanet-like striking surfaces.

MATERIAL

Frontplate and resonating Body:
Red Oak (*Quercus rubra*)

FEATURES

Castanet-like striking surface (US patent)
Internal snare wires
Wide sound options
Padded sitting surface

FINISH

Matte

PEDAL & PICKUP CAJONS

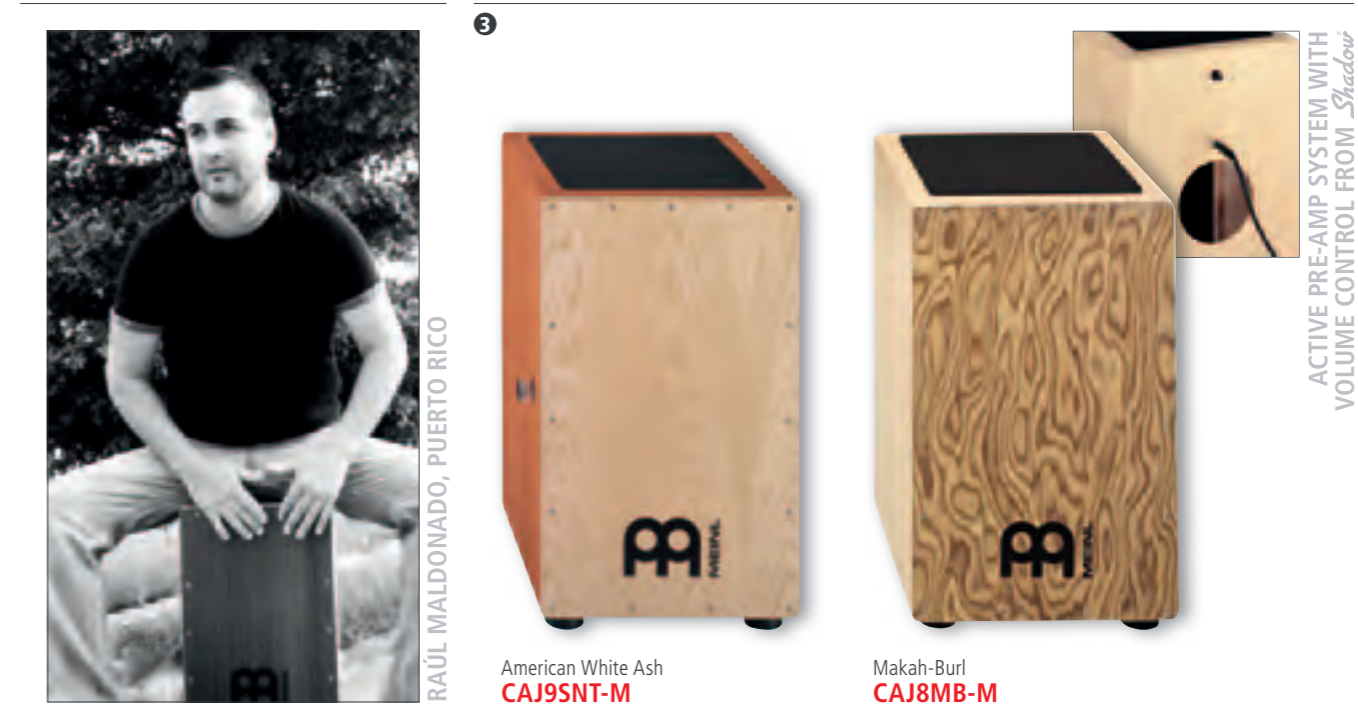

PEDAL CAJONS 1 2

A pedal attached to the cajon adjusts the amount of pressure used to press the snare wires against the front plate, and can even be turned off completely.

MATERIAL

Resonating Body: Rubber Wood (*Hevea brasiliensis* Muell.-Arg.)

FEATURES

Foot pedal (US patent)
Internal adjustable snare wires
Adjustable top corners
Padded sitting surface

FINISH

Matte

1 ERGO-SHAPE PEDAL CAJON (PATENTED)

MATERIAL

Frontplate: Bubinga
Ergo-Shape (DE, US patent)
Foot pedal (US patent)

2 BASS PEDAL CAJON (US PATENT)

MATERIAL

Frontplate: Ebony

FEATURES

Great bass tones
Wide sound options
Foot pedal (US patent)

3 PICKUP CAJONS

The MEINL Pickup Cajons are equipped with a pickup microphone and a pre-amp system with volume control from Shadow®. This active system includes a specially designed pre-amp, high quality endpin output jack and a durable battery.

MATERIALS

Resonating body: Rubber Wood (*Hevea brasiliensis* Muell.-Arg.)

CAJ9SNT-M

Frontplate: American White Ash (*Fraxinus americana* L.)

FEATURES

Pickup microphone
Active pre-amp system with volume control from Shadow®
Adjustable top corners
Padded sitting surface
Wide sound options

CAJ8MB-M

Internal, adjustable snare wires
CAJ8MB-M
Adjustable sizzle effect with integrated string mute system (US patent)

INCLUDES

9-volt battery
CAJ8MB-M

Allen wrench

FINISH

Matte



HOW WE MAKE IT

ARTISAN EDITION PERUVIAN CAJONS

Made in Perú

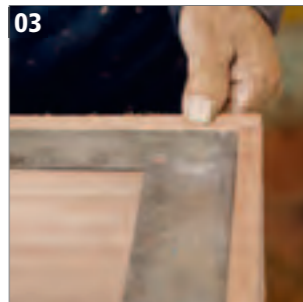

01 Selecting top quality Peruvian Cedar boards.

02 The cajon features dovetail joints, which are the strongest possible in cabinet joinery.

03 The cajon body is inspected to make sure it meets MEINL's high quality standards. The angles are measured to a precise 90 degrees.

04 Carefully measuring and marking the position for the sound hole.

05 The cajon body is planed by hand.

ARTISAN EDITION PERUVIAN CAJONS



HISTORY The first African inhabitants arrived in America with little belongings. They were deprived of everything, including drums, one of their main instruments of expression. The ancient Afro-Americans found their way to obtain new percussion instruments, some of them did it by imitating the instruments left in Africa, and others did it by just creating new ones. During the drum playing prohibition boxes, made to transport merchandise or products, appeared and the authorities thought these boxes were not drums but homemade instruments so they didn't really care about it. Nevertheless, those rustic boxes started little by little to be used to accompany music and they were called "cajones" or "cajas" (boxes).

In Peru today, the cajon is present in almost all kinds of Afro-rooted music (lundero, lando, festejo, alcatraz, toromata, panalivio, inga, etc.), and also accompanies the Peruvian waltz, the Creole polka, the one step, the pasodoble, the tondero and the marinera. Likewise, the cajon has been adopted by many others around the world that are using it for the interpretation of their own music or for recreational purposes.



Reference: Rafael Santa Cruz

CAJONS

1

NEW!



Matte
AE-PCA1

NO SNARES, NO STRINGS – ONLY PURE WOODEN CAJON SOUND. ORIGINAL PERUVIAN STYLE!

2

NEW!



High Gloss
AE-PCA2

AUTHENTIC PERUVIAN CAJONS MADE IN PERU

ARTISAN EDITION PERUVIAN CAJONS 1 2

The MEINL Artisan Edition Peruvian Cajons are hand-made in Perú, where the cajon originated. These beautiful instruments offer truly authentic cajon sound to satisfy the most traditional and demanding players. Dovetail joinery construction allows for beautiful traditional cajon looks. For a crisp modern sound with pronounced bass and cutting slap select our AE-PCA1 matte finished model. For the most traditional cajon sound with earthy lows and subdued highs select our AE-PCA2 gloss finished model.

1 FESTEJO LINE, MATTE

MATERIAL 100% Authentic Peruvian Cedar (*Cedrela odorata*)
1-ply solid body
FEATURES Dovetail joinery construction
Matte finish for a crisp modern sound with pronounced bass and cutting slap
Thick resonating body and thin front plate
Specially formulated rubber feet
The heat-branded logo adds to the mystique
FINISH Matte

2 FESTEJO LINE, HIGH GLOSS

MATERIAL 100% Authentic Peruvian Cedar (*Cedrela odorata*)
1-ply solid body
FEATURES Dovetail joinery construction
Gloss finish for earthy lows and subdued highs
Thick resonating body and thin front plate
Specially formulated rubber feet
The heat-branded logo adds to the mystique
FINISH High Gloss



HOW WE MAKE IT

EACH ARTISAN EDITION FLAMENCO CAJON IS BRANDED WITH A HOT IRON PRESS.



HOW WE MAKE IT

SNARE WIRES ARE HAMMERED INTO GROOVES CUT INTO THE CAJON BODY.

1

Soleá Line, Espresso Burst
AE-CAJ3

NEW!

2

Soleá Line, Ebony Burst
AE-CAJ3BK

3

Bulería Line, Lava-Burl
AE-CAJ5

NEW!

4

Seguiriya Line, Palo Santo
AE-CAJ7PS

3

Cantina Line, Walnut
AE-CAJ6

NEW!

4

Seguiriya Line, Canyon-Burl
AE-CAJ7

SPECIAL HAMMER TONE FINISH FOR BETTER FEEL AND GRIP

UNCOMPROMISING CRAFTSMANSHIP

ERGONOMICALLY CURVED AND ROUNDED FRONTPLATE WITH CONCAVE CONTACT

ARTISAN EDITION FLAMENCO CAJONS
1 2 3 4
 MEINL Artisan Edition Flamenco Cajons are hand made in Spain with uncompromising craftsmanship for the most discerning of players. They are the finest cajons available on the market.



1 SOLEÁ LINE
MATERIALS **AE-CAJ3**
 Frontplate: Espresso Burst
 Resonating body: 9 layer Birch Wood (*Betula pendula*)
AE-CAJ3BK
 Frontplate: Ebony Burst
 Resonating body: 9 layer Birch Wood (*Betula pendula*)
FEATURES 10 pre-tuned upright strings
 Ergonomically rounded frontplate with convex contact
 Specially formulated rubber feet
 Internal Bass Filter for sound compression
 Distinguished heat branding
FINISH Satin

2 BULERÍA LINE
MATERIALS Frontplate: Lava-Burl
 Resonating body: 9 layer of Birch Wood (*Betula pendula*)
FEATURES Double 5-string tuneable snare arrays
 Ergonomically rounded frontplate with convex contact
 Specially formulated rubber feet
 Internal Bass Filter for sound compression
 Distinguished heat branding
INCLUDES Tuning key
FINISH Satin

3 CANTINA LINE
MATERIALS Frontplate: Walnut
 Resonating body: 9 layer Birch Wood (*Betula pendula*)
FEATURES 16 vertical strings
 Strings are adjustable from the top
 Ergonomically rounded frontplate with convex contact
 Specially formulated rubber feet
 Full bass spectrum due to bigger size
 Angeled playing surface
 Distinguished heat branding
INCLUDES Tuning key
FINISH Satin

4 SEGUIRIYA LINE
MATERIALS **AE-CAJ7**
 Frontplate: Canyon-Burl
 Resonating body: 11 layer Birch Wood (*Betula pendula*)
AE-CAJ7PS
 Frontplate: Palo Santo
 Resonating body: 11 layer Birch Wood (*Betula pendula*)
FEATURES 16 adjustable, vertical strings
 Ergonomically curved and rounded frontplate with concave contact
 Specially formulated soft rubber feet
 Extra sound port ring for compression
 Decorative wood inlay
 Distinguished heat branding
INCLUDES Tuning key
FINISH Satin



JUAN CARLOS MELIAN, SPAIN



SUPER LOW FREQUENCY

American White Ash
SUBCAJ1AWA

MICHAEL BUCHNER: INVENTOR OF PROFESSIONAL BONGO CAJON, SLAP-TOP CAJON AND SUBWOOFER CAJON



Ebony
TRECAJ2EB-M

ANGLED FRONTPLATE FOR MORE PLAYING COMFORT

INVENTOR: AREND SCHMIDT-LANDMEIER



Makah-Burl
TOPCAJ1MB

COMFORT DESIGN FOR A MORE UPRIGHT PLAYING STYLE (PATENT PENDING)



COMFORT DESIGN FOR A MORE UPRIGHT PLAYING STYLE (PATENT PENDING)



Natural/Ebony Black, 7" & 8 1/2"
PBCA1NT/EBK-M

FORWARD SOUND PROJECTION



Makah-Burl
PLCA1MB-M

ADJUSTABLE SIZZLE EFFECT



Natural/Ebony Black
BCA2NT/EBK-M

Super Natural
BCA1SNT-M

TWO DIFFERENT SIZED CHAMBERS ENABLE AN AUTHENTIC BONGO EFFECT



Natural
CCA1NT



Brown
MARIMBULA

NEW!

1 SUBWOOFER CAJON

The MEINL Subwoofer Cajon features a forward projecting sound port in place of the traditional rear facing style and an internal reflex channel. This results in an enhanced bass note projection, particularly desirable for live and unplugged situations.

MATERIALS Resonating body: Eco-friendly medium density fibreboard
Frontplate: American White Ash (*Fraxinus Americana* L.)

FEATURES Super low frequency
Forward projecting sound port
Internal snare wires
Adjustable top corners

FINISH Matte

2 TREJON

The Trejon is similar to a drum set in that bass, snare, and tom sounds are in easy reach on the comfortably angled playing surface.

MATERIALS Frontplate: Ebony
Resonating Body: Rubber Wood (*Hevea brasiliensis* Muell.-Arg.)

FEATURES Angled playing surface
Two internal snare wires
Adjustable top corners
Padded sitting surface

3 SLAP-TOP CAJON (PATENT PENDING)

The MEINL Slap-Top Cajon is a conceptual step up to a new level. This model is designed to bring the striking surface up nearer to the player, for a more upright playing style. The sound projects forward into the audience! High and low tones as well as a snare effect are built in to the sound board.

MATERIALS Resonating body: Eco-friendly medium density fibreboard
Frontplate: Makah-Burl

FEATURES Comfortable design
Forward sound projection
Internal snare wires
Wide sound spectrum

4 PROFESSIONAL BONGO CAJON (DE PATENT)

5 BONGO CAJONS
The MEINL Snare Bongo Cajon can be played like a bongo, between the legs, or on one's lap. The professional version has a forward sound projection.

MATERIAL Rubber Wood (*Hevea brasiliensis* Muell.-Arg.)

FEATURES High- and low pitch playing surface
Compact size and light weight
BCA2NT/EBK-M: Internal snare wires
PBCA1NT/EBK-M: (DE patent)
High and low striking surfaces
Forward sound projection
Comfortable design

COLOURS **NT/EBK-M:** Natural/Ebony Black
SNT-M: Super Natural

6 PALITO

Strings which touch the playing surface on the inside deliver a sensitive sizzle effect that fits to various musical applications.

MATERIALS Playing surface: Makah-Burl
Resonating body: Rubber Wood (*Hevea brasiliensis* Muell.-Arg.)

FEATURES Adjustable sizzle effect
Compact size

INCLUDES Allen wrench

7 CAJITA

The MEINL Cajita is developed from the classic Peruvian folk instrument. It hangs from the neck and is played with a wooden striker in one hand. The other hand controls the handle on the lid.

MATERIAL Rubber Wood (*Hevea brasiliensis* Muell.-Arg.)

FEATURES Soft nylon cord
Solid piano hinge
Easy-grip handle

INCLUDES Wooden striker

8 MARIMBULA

The body of this Caribbean instrument is made out of Rubber Wood and has eight tongues in front of it. The Marimbula can also be played with soft mallets.

MATERIALS Rubber Wood (*Hevea brasiliensis* Muell.-Arg.)
Steel tongues

FEATURES Tuning: f c G D F A d g
Solid construction
Heavy duty rubber feet for a solid base

COLOUR Brown
FINISH Matte

NEW!



ASSEMBLY INSTRUCTION COMES IN SEVEN LANGUAGES

Baltic Birch
MYO-CAJ



MAKE YOUR OWN CAJON

One of the most popular percussion instruments today is the Cajon and now with the new MEINL Cajon Kit you can build your own. The kit comes with all the parts and a list of the materials and tools you need. The instructions will guide you through this fun project and at the end you will be able to customize the finish of the instrument by adding oil, a lacquer, wax, or paint it with an entirely unique design.

SIZE 11 3/4" W x 18" H x 11 3/4" D

MATERIALS Baltic Birch (*Betula*)
Steel snare wires

DELIVERY INCLUDES

- 1 x assembly instructions in seven languages
- 2 x side panels
- 1 x base panel
- 1 x top panel
- 1 x rear panel
- 1 x playing surface (with MEINL logo)
- 2 x side battens
- 1 x base & 1 x top batten
- 1 x securing batten for the snare
- 1 x snare
- 4 x rubber feet
- 15 x screws 3 x 20 mm (for playing surface)
- 4 x screws 4 x 15 mm (for rubber feet)
- 2 x screws 3 x 12 mm (for snare)

COLOUR Natural

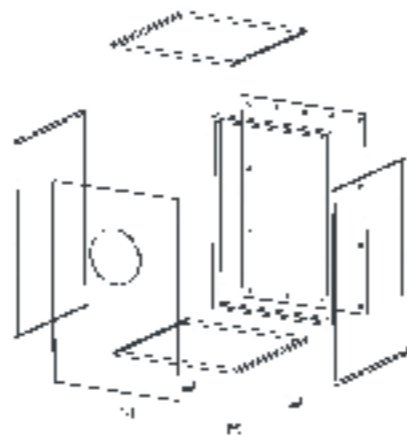

NEW!



CAJONS

Baltic Birch
MYO-BCAJ



MAKE YOUR OWN BONGO CAJON

A very popular item from the MEINL ultimate selection of instruments is the Bongo Cajon and now you can build your own with this construction kit. The kit comes with all the parts and a list of the materials and tools you need. The instructions will guide you through this fun project and at the end you will be able to customize the finish of the instrument by adding oil, a lacquer, wax, or paint it with an entirely unique design.

SIZE 15 3/4" W x 7 1/4" D x 6 3/4" H

MATERIAL Baltic Birch (*Betula*)

DELIVERY INCLUDES

- 1 x assembly instructions in seven languages
- 2 x side panels, long
- 2 x side panels, short
- 1 x playing surface (with MEINL logo)
- 1 x sound chamber partition

COLOUR Natural

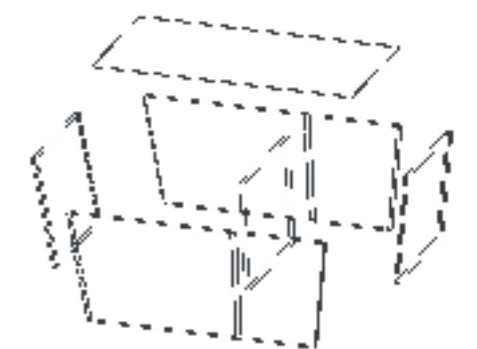



FOOT PERCUSSION

1

HOLGER MERTIN, GERMANY



SOUNDS

- 0 - Kick Bass
- 1 - Cyber Kick
- 2 - Tribal Bass
- 3 - Straight Tambourine
- 4 - Double Tambourine
- 5 - Clave
- 6 - Hand Clap
- 7 - Dry Cowbell
- 8 - Straight Cabasa
- 9 - Double Cabasa



10 sound options
FX10

FRONT VIEW

A WHOLE PERCUSSION KIT IN A BOX

2



INVENTOR: TORSTEN FRANZ



Additional springs with more tension
SPARE-20

Large
FCA5-L

3

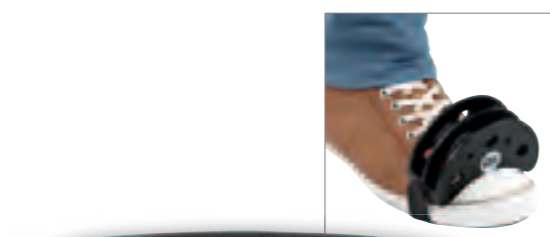

INVENTOR: MICHAEL BUCHNER



Stainless steel
FJS2S-BK

1 FX PEDAL

The MEINL FX Pedal features 10 different sound options that you can add to your beat. Cycle through the effects with a touch of the toe button. It's a whole percussion kit in a box! Plug in and groove...

MATERIALS Oak (*Quercus (robur) pedunculata*) and steel box

FEATURES Microprocessor controls
10 different sound options
Sound select button
Stereo/Mono output
Made in Germany by Shadow

INCLUDES Hook and loop fastener with spikes
International power converter

2 FOOT CABASA (US PATENT)

The MEINL Foot Cabasa is a breakthrough instrument for the percussionist! We mounted a large Turbo Cabasa on our sturdy foot pedal (US patent), which adds a new sound to your setup. Keep a cabasa rhythm while your hands play the congas or other drums! The MEINL Foot Cabasa can be set for either a single or double-stroke, according to your taste.

SIZE Large
MATERIALS Steel chain and stainless steel cylinder
Wooden body
Black powder coated pedal

FEATURES Optional single or double-stroke setting
5 sound ports on each side for more volume (CN, DE, US patent)

INCLUDES Drum key
Foot pedal

3 FOOT TAMBOURINE

The Foot Tambourine is a perfect compliment for virtually any instrument. It's light and versatile, yet not overpowering, delivering a sensitive accompaniment. Easily mounted on your foot, it will go with any beat.

MATERIAL Rubber Wood (*Hevea brasiliensis* Muell.-Arg.)
FEATURES Bright, light accent for any instrument
Ergonomic design
Hassle-free mounting
Stainless steel jingles

COLOUR **BK**: Black

CAJON ADD-ONS

1



INVENTOR: MICHAEL BUCHNER



Black
WSS1BK



ADD NEW SOUNDS TO YOUR CAJON

CAJON ADD-ONS

2



Small
WC1-S

Medium
WC1-M

Large
WC1-L

3



Medium
WJC1-M

1 WOOD SIDE SNARE

The Wood Side Snare for cajons takes your sound up to another level. Self-adhesive tape securely holds the ergonomically shaped box to any side of the Cajon. The player decides the perfect spot. It can be removed as desired.

MATERIAL Rubber Wood (*Hevea brasiliensis* Muell.-Arg.)

FEATURES Internal snare effect
Hook and loop fastener attaches to Cajon body
Ergonomic shape
Unobtrusive low profile

COLOUR **BK**: Black
FINISH Matte

2 CAJON CASTANETS

Our lightweight Castanets come in three sizes, and with hook and loop fastener. Stick them anywhere to add new colours to your cajon or any other instrument!

SIZES Small
Medium
Large

MATERIAL Rubber Wood (*Hevea brasiliensis* Muell.-Arg.)

FEATURES Spring-opened
Hook and loop fastener goes on any surface

COLOUR Black
FINISH Matte

3 CAJON JINGLE CASTANET

The MEINL Cajon Jingle Castanet adds another accent to the Cajon. A pair of steel jingles gives a light metallic touch to the fundamental wooden Castanet. Various finger techniques produce changeable sounds. Like all our Cajon Castanets, self-adhesive tape application means they go easily on your cajon, or anywhere else.

SIZE Medium
MATERIAL Rubber Wood (*Hevea brasiliensis* Muell.-Arg.)

FEATURES Spring-opened
Hook and loop fastener goes on any surface
Steel Jingles

COLOUR Black
FINISH Matte



CAJON ADD-ONS

1 IMPROVED!



Black
TCAJ1BK

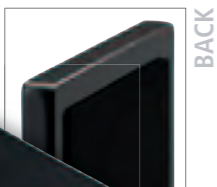

BACK

3



Medium
JT-S-BK

NEW!

2



Black
CAJ-BLK

NEW!

EXTRA POCKET FOR SMALL PERCUSSION

4



Large
CSM-L

NEW!

DESIGNED TO HOLD OUR CAJON ADD-ONS CLOSE TO THE PLAYING SURFACE

Medium
CSM-M



NEW!

5



Black
KP-JT-BK

NEW!

6



Black
KP-ST-BK

NEW!

INTERNAL SNARE WIRES



7



Steel jingles
FJS1S-BK

Aluminum jingles
FJS1A-BK

NEW!

NEW!

ERGONOMICALLY DESIGN



MICHAEL BUCHNER: INVENTOR OF JINGLE TAP, CAJON SIDE MOUNTS, KNEE PAD JINGLE AND SNARE TAP, FINGER JINGLES

1 TRAVEL CAJON

The MEINL Travel Cajon is a great way to practice cajon techniques while on the go or when you need to keep the volume way down. It is perfect for keeping your chops in shape, any time, anywhere!

SIZE 11 3/4"
MATERIAL Rubber Wood
(*Hevea brasiliensis* Muell.-Arg.)

FEATURES Internal snare wires
Compact design
Sound port for clear sound projection
Great way to practice cajon techniques while on the go

COLOUR BK: Black
FINISH Matte



2 CAJON BLANKET

The MEINL Cajon Blanket is an excellent addition to your cajon that will help you make good use of space. The blanket is attached with a string to the bottom of the cajon and features on top a padded sitting area for comfort. On one side the blanket has a pocket for extra percussion instruments storage while the other side is prepared with hook and loop fastener to allow the attachment of different cajon add-ons.

MATERIAL Heavy duty nylon
FEATURES Fits on any cajon
Hook and loop fastener to mount additional add-ons
Extra pocket for small percussion
COLOUR Black

3 JINGLE TAP

The MEINL Jingle Tap is part of the cajon add-ons that you can mount anywhere with hook and loop fastener to expand the possibilities on your set. The steel jingles will give a nice accent to almost any musical situation.

SIZE Medium
MATERIAL Rubber Wood
(*Hevea brasiliensis* Muell.-Arg.)

FEATURES Steel jingles
Hook and loop fastener goes on any surface

COLOUR BK: Black

4 CAJON SIDE MOUNTS

The MEINL Cajon Side Mounts were designed to hold our cajon add-ons close to the playing surface in order to offer you more musical possibilities. The mount comes in large and medium size and is easily placed by simple hook and loop fastener.

SIZES Medium
Large
MATERIAL Rubber Wood
(*Hevea brasiliensis* Muell.-Arg.)

FEATURES Easy handling
Hook and loop fastener goes on any surface
Offers better cajon accessory placement
COLOUR Black

5 KNEE PAD JINGLE TAP

The new MEINL Knee Pad Jingle Tap is another addition to the big collection of cajon add-ons. It comes with a strap that allows you to attach it to your leg for easy access when playing.

MATERIAL Rubber Wood
(*Hevea brasiliensis* Muell.-Arg.)

FEATURES Steel jingles
Strap with hook and loop fastener to mount on your leg
COLOUR BK: Black

6 KNEE PAD SNARE TAP

The MEINL Knee Pad Snare Tap will bring the snare sound to your set up. The strap helps you secure it to your leg and in minutes you are ready to play.

MATERIAL Rubber Wood
(*Hevea brasiliensis* Muell.-Arg.)

FEATURES Snare effect
Strap with hook and loop fastener to mount on your leg
COLOUR BK: Black

7 FINGER JINGLES

The MEINL finger jingles are small in size but big in sound by offering infinite possibilities to the percussion player without adding too much weight to the percussion bag. They are lightweight and ergonomically designed for comfort when playing.

MATERIALS FJS1S: Steel jingles
FJS1A: Aluminum jingles
Rubber Wood
(*Hevea brasiliensis* Muell.-Arg.)

FEATURES Ergonomically design
Comfortable handling
COLOUR BK: Black

HOW WE MAKE IT

- 01** The first tack welds make it into a raw drum body.
- 02** Rollers form the body flanges, which are important for stability and a proper dry Cascara sound.
- 03** Here you see raw components for the Luis Conte Signature Timbales. The freshly cast mounting brackets will be cut free and individually polished. In the background, note the heavily hammered texture in the center portion of the shell stock.
- 04** The MEINL Luis Conte Signature Timbales have a hammered texture. This is applied before the body is rolled into shape.



Chrome, 13" & 14"
HT1314CH

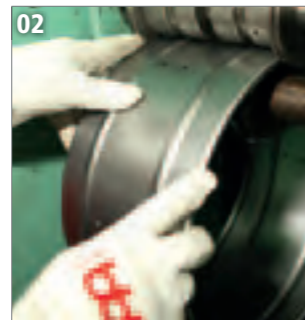

HEADLINER® SERIES TIMBALES (PATENTED)
The MEINL Headliner® Series Timbales come in 13" and 14" sizes, are made from chrome plated steel, and come with a heavy-duty, height adjustable tilting stand. They provide the classic timbale sound and are the perfect introduction to the joy and passion of timbale playing at an affordable price.

SIZES 13" & 14"
MATERIAL Steel
FEATURE Logo applied from underneath the head (CN, US patent)
INCLUDES Height adjustable tilting double braced tripod stand
Tuning key
Wrench
Cowbell holder
FINISH Chrome



YUYISNEY AGUILAR, SPAIN



Chrome, 14" & 15"
MT1415CH

Brass, 14" & 15"
MT1415B



Black nickel, 14" & 15"
MT1415BN

Antique Finish, 14" & 15"
MT1415RR-M

MARATHON® SERIES TIMBALES (PATENTED)
MEINL Marathon® Series Timbales are professionally equipped yet are offered at an affordable price. They are perfect for the working percussionist or to be included in a drum setup.

SIZES 14" & 15"
MATERIAL Steel
FEATURES Two worked in flanges
Heavy duty style brackets
Logo applied from underneath the head (CN, US patent)

INCLUDES Adjustable cowbell holder
Height adjustable tilting double braced tripod stand
Accessory pouch
L-shaped tuning key
Tune Up Oil

FINISHES **B:** Brass
BN: Black nickel
CH: Chrome
RR-M: Antique Finish, matte



JIMMY BRANLY, USA



FLOATUNE, ARTIST & TURBO TIMBALES

1



BLACK POWDER COATING FOR DRY AND CUTTING SOUNDS

Black, 13" & 14"
TI1BK

2



AMADITO VALDÈS, CUBA

Black, 14" & 15"
AV1BK

3



EXTRA DEEP SHELLS FOR SUPER PROJECTION AND GREAT BASS TONES

Black, 14" & 15"
MTT1415BK

FLOATUNE SERIES TIMBALES 1 2

MATERIAL Black powder coated steel

FEATURES Two worked in flanges
Floatune Tuning System
Logo applied from underneath the head (CN, US patent)

INCLUDES Adjustable cowbell holder
Height adjustable tilting double braced tripod stand
Accessory pouch
L-shaped tuning key
Tune Up Oil

COLOUR Black

1 FLOATUNE SERIES (PATENTED)

The MEINL Floatune Tuning System used on these timbales works without having to drill into the shell.

SIZES 13" & 14"

2 ARTIST SERIES TIMBALES (AMADITO VALDÈS) (PATENTED)

Our Artist Series Amadito Valdès Timbales – a tribute to one of the greatest timbaleros ever. Featuring our Floatune Tuning System and produce a dry and cutting sound due to the black powder coated shells.

SIZES 14" & 15"

3 MARATHON® SERIES TURBO TIMBALES (PATENTED)

The MEINL Turbo Timbales come with extra deep shells for super projection and great bass tones. Black

powder coating on the outside produces a dry, crisp and warm response.

SIZES 14" & 15"
10" deep

MATERIAL Black powder coated steel

FEATURES Three worked-in flanges
Heavy Duty style brackets
Logo applied from underneath the head (CN, US patent)

INCLUDES Adjustable cowbell holder
Height adjustable tilting double braced tripod stand
Accessory pouch
L-shaped tuning key
Tune Up oil

COLOUR **BK:** Black

ARTIST & PROFESSIONAL SERIES TIMBALES

1



LUIS CONTE, USA



Stainless steel, 14" & 15"
LC1STS

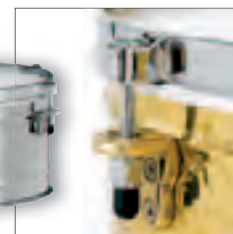

COUNTER SUNK BOLT HEAD AND BRACKET CAST FROM SPECIAL ALLOY



Solid brass, 14" & 15"
LC1BRASS



2



THOUGHTFULLY ARRANGED LUGS ENABLE AN EASY WAY TO PLAY THE CASCARA

German B8 cymbal bronze, 14" & 15"
BT1415



1 ARTIST SERIES TIMBALES (LUIS CONTE) (PATENTED)

It is with the greatest appreciation and the deepest respect that we honour our friend Luis and his life's work with his MEINL Artist Series Luis Conte Signature Timbales. Perfection in even the smallest details has been achieved in this outstanding instrument. All of the specifications Luis required for his instrument have been consequently realized.

SIZES 14" & 15"

MATERIALS **LC1BRASS:** Solid brass
LC1STS: Stainless steel

FEATURES Extensively hammered shells
Two worked in flanges
Cuban style flared out bottom edge

Brackets cast from special brass alloy
Logo applied from underneath the head (CN, US patent)

INCLUDES Adjustable cowbell holder
Height adjustable tilting double braced tripod stand
Accessory pouch
L-shaped tuning key
Tune Up Oil

2 PROFESSIONAL SERIES TIMBALES (PATENTED)

The Roland Meinl Professional Series Timbales are made from finest German B8 cymbal bronze. They produce a fantastic warm sound with cutting rim shots and enhanced Cascara playing.

SIZES 14" & 15"

MATERIAL German B8 cymbal bronze

FEATURES Two worked in flanges
Cuban style flared out bottom edge
Brackets cast from special brass alloy
Logo applied from underneath the head (CN, US patent)

INCLUDES Adjustable cowbell holder
Height adjustable tilting double braced tripod stand
Accessory pouch
L-shaped tuning key
Tune Up Oil

ADD PERC TO YOUR KIT

Tommy Clufetos (Ozzy Osbourne) uses MEINL Professional Congas and Attack Timbales in his setup.



DIRK VERBEUREN, BELGIUM



BENNY GREB, GERMANY



BRAM HAKKEN'S, NETHERLANDS



JULIO FIGUEROA, USA



JOHNNY RABB, USA



GREG BISHOP, UK



TOMMY CLUFETOS, USA



DRUMMER TIMBALES & HAND-BALE



1

SNARE WIRES ARE ABSOLUTELY QUIET AND CHATTER-FREE IN THE "OFF" POSITION

2



Chrome, 8" & 10"
MIT810CH



Chrome, 13"
MDT13CH



Black, 10"
MDST10BK

Black, 8"
MDST8BK



CHAD WACKERMAN, USA



TAKU HIRANO, USA

3

Taku Ito



Black, 13"
MHT13BK



SPECIAL DESIGNED RIM

4



Black nickel, 8"x9", 8"x11"
MDT88BN

STRONG MOUNTING CLAMPS



DAVE MACKINTOSH, UK

1 DRUMMER SNARE TIMBALES (PATENTED)

The Drummer Snare Timbales feature a crisp snare effect. The super-positive snare throw-off is fast and simple. We designed a special bracket to hold the snare wires absolutely quiet and chatter-free in the "off" position.

SIZES 8", 10"

MATERIAL Steel

FEATURES Strong mounting clamp
Quick snare on/off system
Chatter-free "off" position
Logo applied from underneath the head (CN, US patent)

COLOUR **BK:** Black

2 DRUMMER TIMBALE MINI TIMBALES (PATENTED)

The MEINL Drummer and Mini Timbales provide the characteristic timbale sounds and projection that cuts through any band setting. It is a perfect addition to any percussion or drum set configuration.

SIZES **MDT13CH:** 13" drummer timbale

MIT810CH: 8" & 10" mini timbale

MATERIAL Steel

FEATURES Strong mounting clamp
Logo applied from underneath the head (CN, US patent)

INCLUDES L-shaped tuning key

Tune Up Oil

FINISH Chrome

3 ARTIST SERIES HAND-BALE (TAKU HIRANO) (PATENTED)

No sticks? No problem!

The retaining rim of the Hand-Bale is uniquely made with one half traditionally shaped, while the other half of the rim is recessed below the shell.

SIZE 13"

MATERIAL Steel

FEATURES Special designed rim
Strong mounting clamp
Logo applied from underneath the head (CN, US patent)

INCLUDES L-shaped tuning key

Tune Up Oil

COLOUR **BK:** Black, high gloss

4 ARTIST SERIES ATTACK TIMBALES (DAVE MACKINTOSH) (PATENTED)

We made a pair of 8" diameter timbale shells with a depth of 9" and 11" respectively. This creates a distinctive and tightly matched interval "dialogue". The Dave Mackintosh's Signature Attack Timbales are easily mounted on a rack, drum set, or any standard L-rod.

SIZES 8" x 9", 8" x 11"

MATERIAL Steel

FEATURES Strong mounting clamps
Logo applied from underneath the head (CN, US patent)

INCLUDES L-shaped tuning key

Tune Up Oil

COLOUR **BN:** Black Nickel



TMTS

HAND-BALE STAND (SEE PAGE 169)



SAMBA

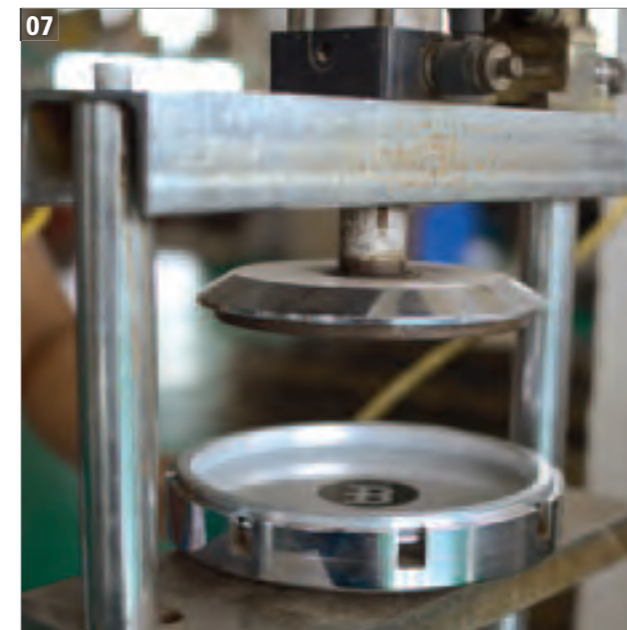

01 Sheets of Poplar Wood for our timbas.

02 A wooden surdo in formation.

03 Initial forming of a surdo body.

04 Surdo body heli-arc welded.

05 The surdos legs have to be parallel.

06 Setting up the surdo with its tuning rods.

07 Tamborim head in the press.

08 The head is fitted to the tamborim.

PUTTING THE LOGO ON A REBOLO.

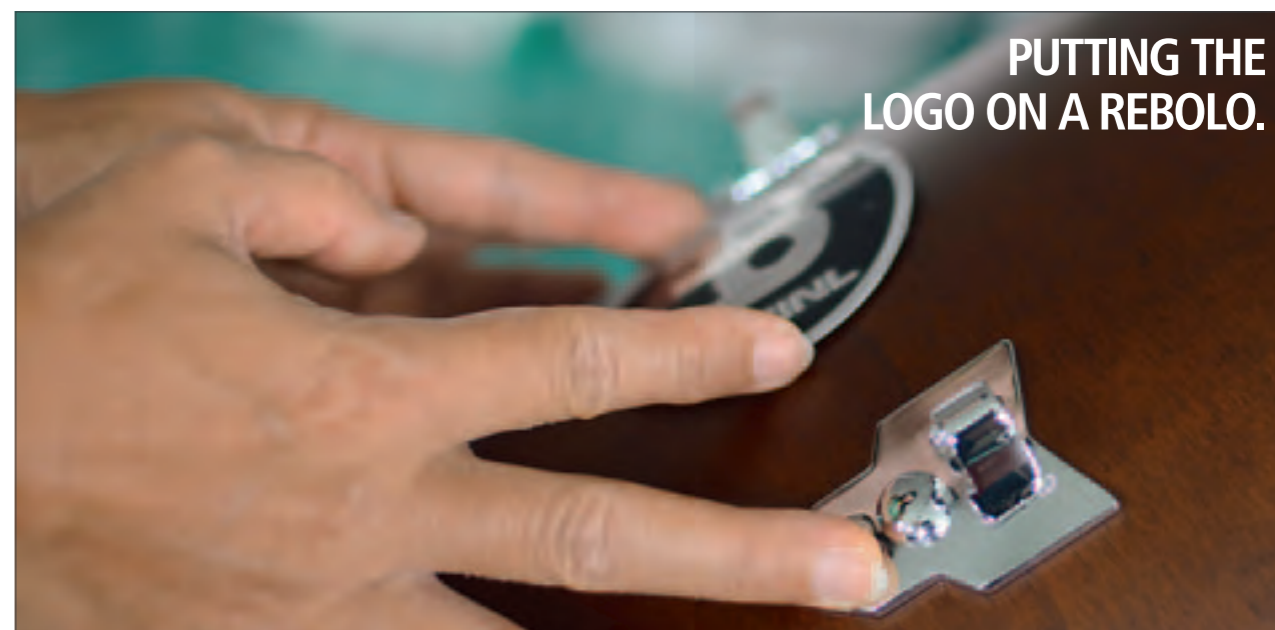



WOUTER DE GOOYERT,
NETHERLANDS



CHARLY BÖCK, GERMANY



MARCO CATINACCIO, ITALY

TOMBACK, ECUADOR

THE ORIGINAL DANCE MUSIC

1



LIGHT WEIGHT ALUMINUM

22"
SU22

20"
SU20

18"
SU18

16"
SU16

2



ALL MEINL SURDOS COME WITH NAPA HEAD ON TOP FOR ANOTHER HEAD OPTION

22"
SU22AB-M

20"
SU20AB-M

18"
SU18AB-M

16"
SU16AB-M

1



22"
SU22-L

20"
SU20-L

18"
SU18-L

16"
SU16-L

2



22"
SU22-L-AB-M

20"
SU20-L-AB-M

18"
SU18-L-AB-M

16"
SU16-L-AB-M

SIX-PLY HARDWOOD SHELLS FOR A FULL AND WARM SOUND

1 TRADITIONAL ALUMINUM SURDOS (PATENTED)

The deep sound of the Surdo is the heartbeat of Samba music. MEINL offers several sizes made from premium aluminum.

SIZES 16" x 20", 18" x 22", 20" x 24", 22" x 24"

MATERIAL Aluminum

FEATURES Countersunk bolt heads
Chrome plated hardware
Two head options
8 tuning lugs (16" & 18" models)
10 tuning lugs (20" & 22" models)
Logo applied from underneath the head (CN, US patent)

INCLUDES Tuning key

2 TRADITIONAL WOOD SURDOS (PATENTED)

The MEINL Wood Surdos have all the great features of our Aluminium Surdos, but with wooden shells for a warmer sound. They deliver the full bass notes that are the heartbeat of Samba music.

SIZES 16" x 20", 18" x 22", 20" x 24", 22" x 24"

MATERIAL Six-ply hardwood shells

FEATURES Countersunk bolt heads
Chrome plated hardware
Two head options
8 tuning lugs (16" & 18" models)
10 tuning lugs (20" & 22" models)
Logo applied from underneath the head (CN, US patent)

INCLUDES Tuning key

COLOUR **AB:** African Brown

FINISH Matte



JOSÉ J. CORTIJO, GERMANY

1 TRADITIONAL STAND ALONE ALUMINUM SURDOS (PATENTED)

MEINL percussion offers stand alone Surdos made out of aluminum that are equipped with sturdy, height adjustable legs placed on the floor while playing.

SIZES 16" x 20", 18" x 22", 20" x 24", 22" x 24"

MATERIAL Aluminum

FEATURES Height adjustable legs
Countersunk bolt heads
Chrome plated hardware
Two head options
8 tuning lugs (16" & 18" models)
10 tuning lugs (20" & 22" models)
Logo applied from underneath the head (CN, US patent)

INCLUDES Tuning key

2 TRADITIONAL STAND ALONE WOOD SURDOS (PATENTED)

The MEINL Stand Alone Wood Surdos have all the great features of our aluminum surdos, but with wooden shells for a warmer sound. They deliver the full bass notes that are the heartbeat of Samba music. These surdos are perfect for stationary playing, on stage, or in a drum circle!

SIZES 16" x 20", 18" x 22", 20" x 24", 22" x 24"

MATERIAL Six-ply hardwood shells

FEATURES Height adjustable legs
Countersunk bolt heads
Chrome plated hardware
Two head options
8 tuning lugs (16" & 18" models)
10 tuning lugs (20" & 22" models)
Logo applied from underneath the head (CN, US patent)

INCLUDES Tuning key

COLOUR **AB:** African Brown

FINISH Matte



22" **SUB22** 20" **SUB20** 18" **SUB18**

SHORTER SHELLS
ENABLE TO WEAR IN MUCH LOWER POSITION



22" **SUB22AB-M** 20" **SUB20AB-M** 18" **SUB18AB-M**

1 BAHIA ALUMINUM SURDOS (PATENTED)
Bahia Surdos are made to celebrate Samba-Reggae. Each surdo is cut shorter than its Rio counterpart and typically worn much lower, on a belt. Our three sizes offer two great sounding fundos and a higher pitched third-surdo.
SIZES 18" x 16", 20" x 16", 22" x 18"
MATERIAL Aluminum
FEATURES Countersunk bolt heads
Chrome plated hardware
Two head options
8 tuning lugs (18" model)
10 tuning lugs (20" & 22" models)
Logo applied from underneath the head (CN, US patent)
INCLUDES Tuning key

2 BAHIA WOOD SURDOS (PATENTED)
Our wooden Bahia Surdos celebrate Samba-Reggae music with warm-sounding shells. The three sizes offer the classic high-low fundos and a higher pitched third surdo. Each surdo is cut shorter than its Rio counterpart, and typically worn much lower, on a belt.
SIZES 18" x 16", 20" x 16", 22" x 18"
MATERIAL Six-ply hardwood shells
FEATURES Countersunk bolt heads
Chrome plated hardware
Two head options
8 tuning lugs (18" model)
10 tuning lugs (20" & 22" models)
Logo applied from underneath the head (CN, US patent)
INCLUDES Tuning key
COLOUR **AB:** African Brown
FINISH Matte



22" **HEAD-69**

20" **HEAD-68**

18" **HEAD-67**

16" **HEAD-66**

3 NAPA HEADS
The MEINL Napa Heads feature a two-layer construction with a strong, thin Mylar (plastic) under layer, and a soft Napa surface, securely bound together in a metal hoop.
SIZES 16", 18", 20", 22"
MATERIALS Nylon and leather cloth
FEATURE Bonded in a hoop
COLOUR Black

CAIXAS & REPINIQUES



14" x 4" **CA14**



GILSON SILVEIRA, ITALY

12" x 4 1/2" **CA12**

12" x 6" **CA12T**

PROFESSIONAL SNARE
THROW-OFF MECHANISM

TRADITIONAL STYLE WITH
GUITAR STRINGS



12" x 12" **RE12**

10" x 10" **RE10**

12" x 12" **RE12AB-M**



COUNTERSUNK BOLT HEAD



CAIXAS 1 2
With shells made from premium aluminum, these caixas produce the classic bright and cutting sound with penetrating rim shots that these instruments are supposed to deliver.
MATERIAL Aluminum
INCLUDES Tuning key

1 ALUMINUM CAIXAS (PATENTED)
SIZES 12" x 4 1/2"
14" x 4"
FEATURES Replaceable synthetic heads
Countersunk bolt heads
Steel snare wires
Logo applied from underneath the head (CN, US patent)
Professional snare throw-off mechanism

2 TRADITIONAL ALUMINUM CAIXA (PATENTED)
SIZE 12" x 6"
FEATURES Traditional style snares made from guitar strings
Extra deep body
Countersunk bolt heads
Logo applied from underneath the head (CN, US patent)
Replaceable synthetic heads

REPINIQUES 3 4
The Repinique is played with a stick while the other hand is used for open tones and slaps. MEINL offers aluminum and wooden versions.
FEATURES Countersunk bolt heads
Chrome plated hardware
Replaceable synthetic heads

6 tuning lugs (10" model)
8 tuning lugs (12" model)
Logo applied from underneath the head (CN, US patent)
INCLUDES Tuning key

3 ALUMINUM REPINIQUES (PATENTED)
SIZES 10" x 10"
12" x 12"
MATERIAL Aluminum

4 WOOD REPINIQUE (PATENTED)
SIZE 12" x 12"
MATERIAL Rubber Wood
(*Hevea brasiliensis* Muell.-Arg.)
COLOUR **AB:** African Brown
FINISH Matte



TIMBAS & TANTAM & REBOLO

1



14" x 35" **TIM1435AB-M** 14" x 28" **TIM1428AB-M** 14" x 35" **TIM1435NT** 14" x 28" **TIM1428NT**

NEW! NEW!



MARCIO PEETER, USA

2



NAPA HEAD FOR REDUCED OVERTONES



12" x 18" **REB1218AB-M**

3



STRONG HOOK TO CARRY IT ON A BELT



14" x 28" **TAN1428AB-M**

4



SB-R

1 TIMBAS (PATENTED)

The MEINL Timba has a light weight shell, a thin synthetic head, and mechanical lug tuning. The tones are sharp, clear, and bright.

SIZES 14" x 28", 14" x 35"

MATERIAL Poplar Wood (*Populus*)

FEATURES Light weight shell
Replaceable synthetic head
Chrome plated hardware
Comfortable rounded rim
Logo applied from underneath the head (CN, US patent)
Strong hook to carry it on a belt

INCLUDES Tuning key

COLOURS **AB:** African Brown, matte
NT: Natural, high gloss

2 REBOLO

The Rebolo is a Brazilian ensemble drum with warm, deep tones. It comes with a Napa head and is usually played in the seated position.

SIZES 12" x 18"

MATERIAL Poplar Wood (*Populus*)

FEATURES Lightweight shell
Replaceable synthetic Napa head
Chrome plated hardware
Mechanical lug tuning
Strong hooks to carry it on a belt

INCLUDES Tuning Key

COLOUR **AB:** African Brown
FINISH Matte

3 TANTAM

The Tantam is a drum with warm, deep tones, usually played in Pagode, a specific genre of samba.

SIZE 14" x 28"

MATERIAL Poplar Wood (*Populus*)

FEATURES Lightweight shell
Replaceable synthetic Napa head
Chrome plated hardware
Strong hooks to carry it on a belt

INCLUDES Tuning key

COLOUR **AB:** African Brown
FINISH Matte

4 SAMBA BELT

MEINL offers a high quality belt to ensure a safe and comfortable playing of several samba instruments.

MATERIAL Cotton

FEATURES Length adjustable
Adjustable shoulder padding
Strong attachment hooks

COLOUR **R:** Red

CUICAS & WHISTLE & ROCARS & TRIANGLE

1



10" **QW10** 6" **QW6**

2



8" **QW7R**

3



SW1

THREE TONES

4



RC1BK

20 PAIRS OF SOLID JINGLES

6



RC2-L



RC2-M

5



15 3/4" **STRI40**

1 ALUMINUM CUICAS

MEINL offers two cuicas made from lightweight aluminum. Their light weight and solid construction makes them perfect for street Samba.

SIZES 6", 10"

MATERIAL Aluminum

FEATURES Countersunk bolt heads (QW10)
Hand selected goat heads

INCLUDES Tuning key

FEATURES Floatune Tuning System
Hand selected goat head

INCLUDES Tuning key

3 SAMBA WHISTLE

This samba whistle has three tones in a super-bright timbre.

MATERIAL Aluminum

INCLUDES Neck lanyard

4 MODERN STYLE ROCAR

The MEINL Rocar is equipped with 20 pairs of solid jingles mounted onto a wooden bar.

MATERIAL Rubber Wood
(*Hevea brasiliensis* Muell.-Arg.)

FEATURE 20 pairs of solid jingles

COLOUR **BK:** Black

5 SAMBA TRIANGLE

The Samba Triangle is made extra large for a bold sound that can be heard over a Samba ensemble.

SIZE 15 3/4"

MATERIAL Steel

FEATURE Thick steel for extra volume

INCLUDES Extra large Triangle Beater

6 ALUMINUM ROCARS

The MEINL Aluminum Rocars come in lightweight frames that hold an array of cupped aluminum jingles.

SIZES Medium
Large

MATERIAL Aluminum frame and jingles

FEATURES Light weight frame
Loud projection



A-GO-GOS & SHAKERS



TONALLY MATCHED



LIGHT WEIGHT ALUMINUM

1 MODERN STYLE A-GO-GO STEEL FINISH MODELS
The MEINL A-Go-Go Bells are tonally matched especially for the requirements of South American rhythms.

SIZES Small, Large
MATERIAL Special steel alloy
INCLUDES Mounting clamp for small model
FINISH Hand brushed steel

2 MODERN STYLE A-GO-GO CHROME FINISH MODELS
These highly polished A-Go-Go Bells offer a bright sound and are equipped with a flexible connection. Ideal for Samba style music.

SIZES Small, Large
MATERIAL Special steel alloy
FEATURE Flexible connection
FINISH High polished chrome

3 TRADITIONAL STYLE A-GO-GO BELL
The MEINL traditional style A-Go-Go Bell in our medium size is the perfect A-Go-Go Bell when the large is too much and the small one isn't enough.

SIZE Medium
MATERIAL Special steel alloy
FEATURES Traditional shape
Flexible connection
FINISH High polished chrome

4 TRIPLE A GO-GO BELL
The Triple A Go-Go Bell has three tonally matched bells for a sweet sound fitting any musical style. The high bell may be played in counterpoint off the middle bell by compressing the spring handle. Bright chrome finish will hold up under intense play.

SIZE Medium
MATERIAL Chrome plated steel

FEATURES Traditional Shape
Tonally matched bells in equal intervals
Spring handle enables counterpoint rhythms
FINISH Chrome

5 ALUMINUM SAMBA SHAKERS
These are the ideal instruments for street Samba. Their shells are made from thin aluminum, which, when combined with solid steel shot, produce a warm, penetrating, and cutting shaker sound.

SIZES Small, Medium, Large
MATERIAL Aluminum

TAMPEIRO & TAMBORIMS



MESH HEAD FOR SUPER LOW VOLUME PRACTICE

WE OFFER A VARIETY OF TAMBORIMS FROM SEVERAL MATERIALS FOR DIFFERENT SOUND OPTIONS

1 TAMPEIRO (PATENTED)
Three pairs of steel jingles on a wooden tamborim frame create an exciting new sound. A traditional sharp cutting tamborim with a bright metallic accent! It may also be played with pandeiro techniques, for lighter accompaniment.

SIZE 6"
MATERIAL Rubber Wood
(*Hevea brasiliensis* Muell.-Arg.)
FEATURES Floatune Tuning System
Logo applied from underneath the head (CN, US patent)
Countersunk bolt lugs
Replaceable synthetic head
Three pairs of steel jingles
INCLUDES Thai coin as tuning key
COLOUR **AB:** African Brown

2 SILENT TAMBORIM
The MEINL Silent Tamborim is meant for the serious player who wants to perfect their tamborim technique.

SIZE 6"
MATERIALS ABS plastic
Mesh head
FEATURE Mesh head for super low volume practice
COLOUR **BK:** Black

3 FLOATUNE TAMBORIMS (PATENTED)
Tamborims are played with a plastic stick while one hand changes the pitch of the drum. It has a bright, loud, and cutting sound.

SIZE 6"
MATERIALS **ABS:** ABS
ALU: Aluminum
B: Brass plated steel

CH: Chrome plated steel
SNT: Rubber Wood
(*Hevea brasiliensis* Muell.-Arg.)
FEATURES Floatune Tuning System
Logo applied from underneath the head (CN, US patent)
Countersunk bolt lugs
Replaceable synthetic heads
INCLUDES Thai coin as tuning key

4 MESH HEAD FOR TAMBORIMS
The Mesh Head meant for the serious player who wants to perfect their Tamborim technique. Hours of quiet play are possible without sonic overload.

SIZE 6"
MATERIAL Mesh head



HOW WE MAKE IT

FRAME DRUMS



01 After bending the frame, it gets glued and cut into the proper shell depth.

02 The thumb hole of our deep shell frame drums has to be comfortable. Even after the finish is dry we check again.

03 All skins are carefully inspected for faultless quality.

04 A frame is being set with glue, just before the skin goes on.

05 The head is secured to the frame with glue and a band.

06 The extra skin is being removed. The frame drum is sitting inside a cutting guide jig ensuring a perfect cut.

07 The head is tacked securely to the frame.

08 Mounting a True Feel head on a deep shell frame drum.

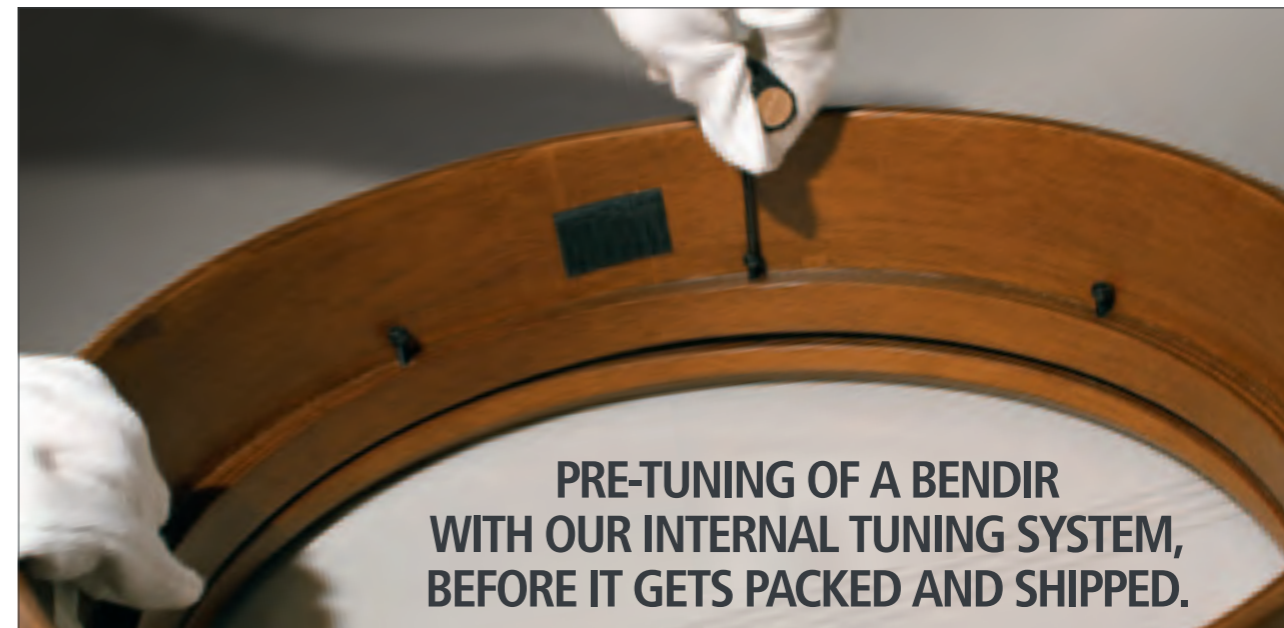
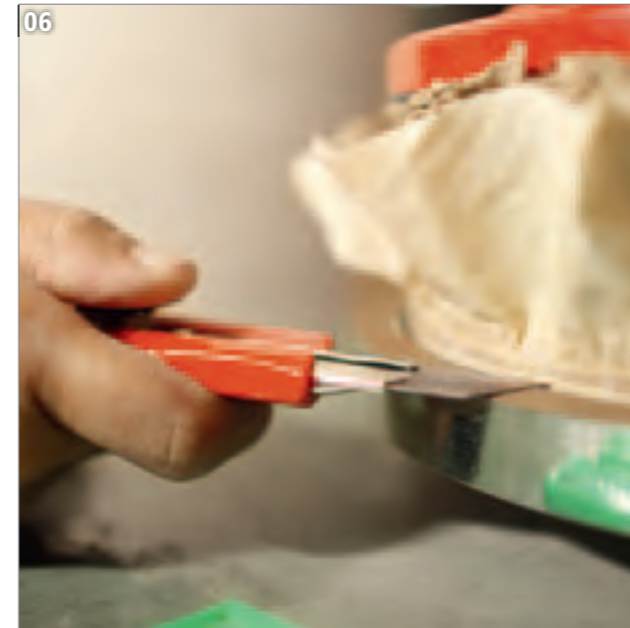
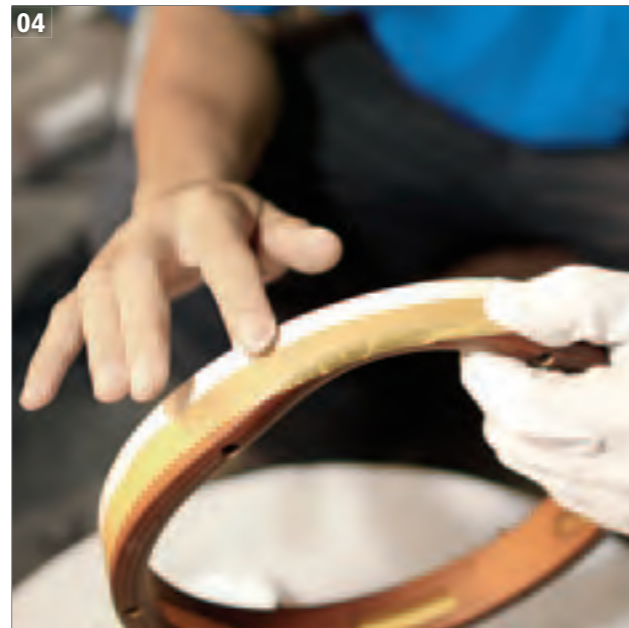

PRE-TUNING OF A BENDIR WITH OUR INTERNAL TUNING SYSTEM, BEFORE IT GETS PACKED AND SHIPPED.

1



INTERNAL LUG TUNING SYSTEM

22" x 2 1/2"
FD22T

20" x 2 1/2"
FD20T

18" x 2 1/2"
FD18T

16" x 2 1/2"
FD16T

2



TRUE FEEL SYNTHETIC HEADS PREVENT THE DRUM'S PITCH FROM BEING AFFECTED BY HUMIDITY IN OUTDOOR VENUES

22" x 2 1/2"
FD22T-TF

20" x 2 1/2"
FD20T-TF

18" x 2 1/2"
FD18T-TF

16" x 2 1/2"
FD16T-TF

TARS 1 2
MEINL Tars are tunable frame drums, available with hand selected goatskin or True Feel synthetic heads. The tuning lugs are fully recessed within the frame for minimal interference. A scalloped thumb notch and light weight ensure comfortable playing.

SIZES 16", 18", 20", 22"
2 1/2" deep

FEATURE Internal lug tuning system

INCLUDES Allen wrench

COLOUR African Brown

FINISH Matte

1 GOAT SKIN TARS
MATERIALS Rubber Wood
(*Hevea brasiliensis* Muell.-Arg.)
Hand selected goat head

2 SYNTHETIC HEAD TARS
MATERIALS Rubber Wood
(*Hevea brasiliensis* Muell.-Arg.)
True Feel synthetic head



TAKU HIRANO, USA

1



DEEP SHELL CONSTRUCTION FOR FULL SOUND DEVELOPMENT

18" x 4"
FD18T-D

14" x 4"
FD14T-D

12" x 4"
FD12T-D

2



18" x 4"
FD18T-D-TF

14" x 4"
FD14T-D-TF

12" x 4"
FD12T-D-TF

MIZHARS 1 2
Mizhars have an internal tuning system, and a traditional thumb hole grip for comfortable playing in the traditional style. The deep shell offers excellent sound development and comes in a stunning burl finish. Those drums are available with a hand selected goat head or with a True Feel synthetic head.

SIZES 12", 14", 18"
4" deep

FEATURES Thumb hole grip
Deep shell construction for full sound development
Internal tuning system
Stunning burl finish

INCLUDES Allen wrench

COLOUR Brown Burl

FINISH Matte

1 GOAT SKIN MIZHARS
MATERIALS Rubber Wood
(*Hevea brasiliensis* Muell.-Arg.)
Hand selected goat head

2 SYNTHETIC HEAD MIZHARS
MATERIALS Rubber Wood
(*Hevea brasiliensis* Muell.-Arg.)
True Feel synthetic head



MC-FDH

FRAME DRUM HOLDER (SEE PAGE 172)



16" x 2 1/2"
FD16BE

14" x 4"
FD14BE

12" x 4"
FD12BE



16" x 2 1/2"
FD16BE-TF

14" x 4"
FD14BE-TF

12" x 4"
FD12BE-TF

BENDIRS 1 2
Bendirs feature four thin strings stretched across the inside of the head, which create the classic Bendir "buzzing" sound. Those drums are fully tunable and light in weight for long and comfortable playing. MEINL offers goatskin as well as synthetic True Feel head versions. This fine frame drums are fully tunable, with rich bass tones and crisp taks. The frame is made for comfort and extended play.

SIZES 12" x 4"
14" x 4"
16" x 2 1/2"

FEATURES Internal tuning system
Buzzing effect
Thumb hole for a good balance and comfortable playing (only for 4" deep frames)

INCLUDES Allen wrench
COLOUR African Brown
FINISH Matte

1 GOAT SKIN BENDIRS
MATERIALS Rubber Wood
(*Hevea brasiliensis* Muell.-Arg.)
Hand selected goat head

2 SYNTHETIC HEAD BENDIRS
MATERIALS Rubber Wood
(*Hevea brasiliensis* Muell.-Arg.)
True Feel synthetic head

BODHRANS 3 4
Bodhrans are known for their earthy and warm tones. MEINL offers two different versions, a Celtic model featuring a cross bar and an Irish model that comes with an extra deep frame and a dampening layer on the head.

3 CELTIC BODHRAN
SIZE 18" x 4"
MATERIALS Rubber Wood
(*Hevea brasiliensis* Muell.-Arg.)
Hand selected goat head

FEATURES Cross bar
Internal tuning system

INCLUDES Allen wrench
COLOUR African Brown
FINISH Matte

BODHRANS & DAFS & KANJIRA



18" x 4"
FD18BO

14" x 6"
FD14IBO

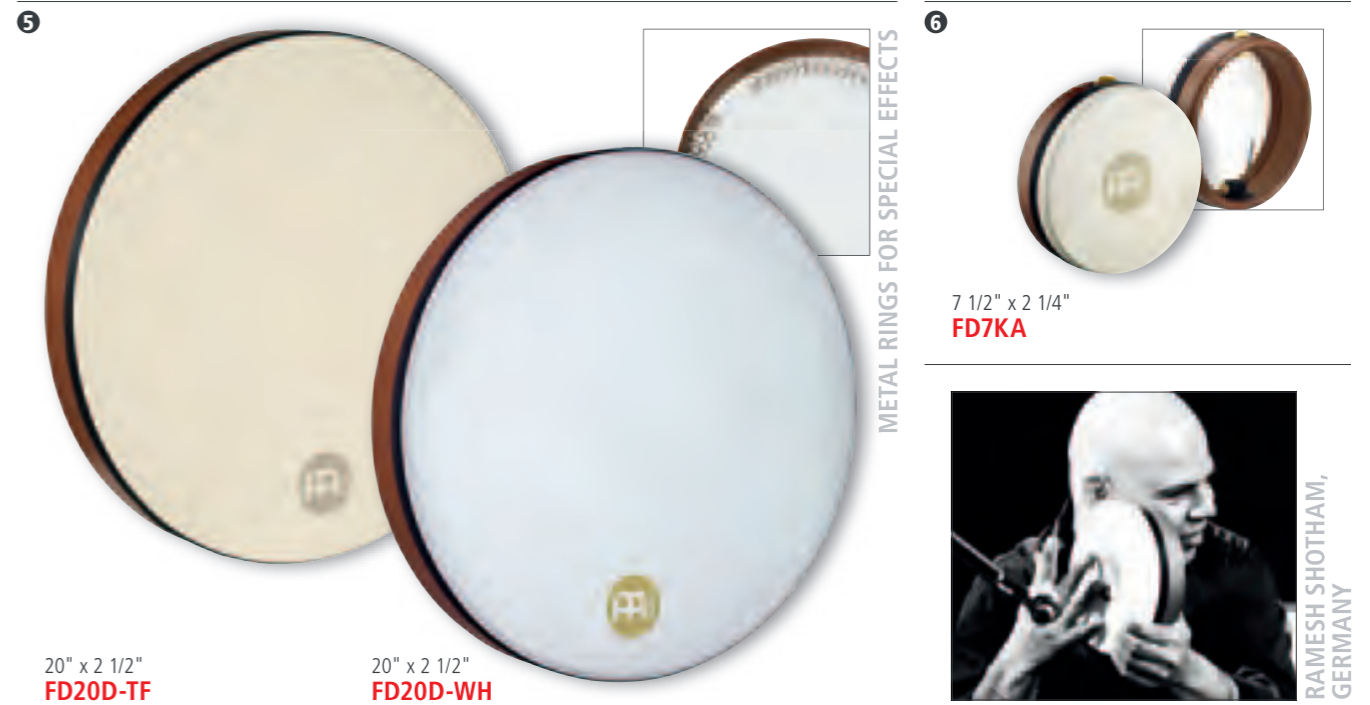

20" x 2 1/2"
FD20D-TF

20" x 2 1/2"
FD20D-WH

7 1/2" x 2 1/4"
FD7KA



RAMESH SHOTHAM,
GERMANY

4 IRISH BODHRAN
The Irish Bodhran features an extra-deep shell for a rich, full sound, and an extra dampening layer on the rim to reduce overtones. The traditional cross brace has been removed to enable direct hand pressure on the head for contemporary pitch-bending techniques.

SIZE 14" x 6"

MATERIALS Rubber Wood
(*Hevea brasiliensis* Muell.-Arg.)
Hand selected goat head

FEATURES Extra deep shell for full sound development
Dampening layer around rim for reduced overtones

INCLUDES Allen wrench
COLOUR Brown Burl
FINISH Matte

5 DAFS
The Daf is a classical Persian frame drum with a rich tradition. It has ring snares nearly all the way around the inside of the shell, and is played with a lot of movement. The MEINL Daf comes either with the a True Feel synthetic head or with a woven texture synthetic head.

SIZE 20" x 2 1/2"

MATERIALS Rubber Wood
(*Hevea brasiliensis* Muell.-Arg.)
FD20D-TF: True Feel synthetic head
FD20D-WH: Woven synthetic head

FEATURES Metal rings for special effects
Pre-tuned construction for extra light weight

COLOUR African Brown
FINISH Matte

6 KANJIRA
The Kanjira is a traditional frame drum from southern India that is played with bending-pitch and split hand techniques. Amazing sounds and complex rhythms are possible from this rich little drum.

SIZE 7 1/2" x 2 1/4"

MATERIALS Rubber Wood
(*Hevea brasiliensis* Muell.-Arg.)
Hand selected goat head

FEATURES Many sound options
Set of 3 jingles

INCLUDES Allen wrench
COLOUR African Brown
FINISH Matte



HOW WE MAKE IT

ARTISAN EDITION TARS & MIZHARS

MEINL is proud to announce that well known frame drum maker Norbert Eckermann will be working with MEINL Percussion to further develop our frame drum line.



The new Artisan Edition Frame Drums are the result of this promising collaboration. The combined effort between Eckermann and MEINL will produce the most outstanding frame drums available today.



01 Milling a special bearing edge into the frame.

02 Cutting frame into two halves for Tars.

03 Hot branding the logo into the frame.

04 Only highest grade hides are used for our Artisan Edition Frame Drums!

ARTISAN EDITION TARS & MIZHARS



1 ARTISAN EDITION TARS (PATENT PENDING)

The MEINL Artisan Edition Tar, is an instrument like no other and a must have for serious players. The heads are made using the highest grade hides available – selected for uniform thickness to give consistent warm tone and response. This drums feature a special bearing edge exclusively designed for our Artisan Edition Tars by Norbert Eckermann.

SIZES 14", 18", 22"; 2 1/2" deep

MATERIALS Rubber Wood
(*Hevea brasiliensis* Muell.-Arg.)
Hand selected goat head

FEATURES Special designed bearing edge (patent pending)
Using highest grade hides available
Internal lug tuning system
Scalloped thumb notch
Hot-branded logo inside of the shell

INCLUDES Allen wrench
COLOUR Walnut Brown
FINISH Matte

2 ARTISAN EDITION MIZHARS (PATENT PENDING)

Originally from Syria, this ancient instrument provides harmonic and rhythmic foundation to the ensemble. In the new MEINL Artisan Edition Mizhars we have used the highest grade hides available – selected for uniform thickness to give consistent warm tone and response. A special designed bearing edge invented by Norbert Eckermann ensures deep dums and crisp taks (teks).

SIZES 14", 18", 22"; 4" deep

MATERIALS Rubber Wood
(*Hevea brasiliensis* Muell.-Arg.)
Hand selected goat head

FEATURES Special designed bearing edge (patent pending)
Using highest grade hides available
Internal tuning system
Thumb hole grip
Hot-branded logo inside of the shell

INCLUDES Allen wrench
COLOUR Walnut Brown
FINISH Matte



HOT-BRANDED LOGO INSIDE OF THE SHELL

FRAME DRUMS

MEINL SEA DRUMS & HAND DRUMS & PLENERA SET

1



SEALABLE FILLING PORT ALLOWS YOU TO CONTROL THE AMOUNT OF STEEL BALLS INSIDE

20" x 2 3/4"
FD20SD

18" x 2 3/4"
FD18SD-TF

16" x 2 3/4"
FD16SD

2



8", 10", 12"
PL-SET

3



15"
HOD15

12 1/2"
HOD125

4

NEW!



16"
HD16AB

14"
HD14AB

12"
HD12AB

10"
HD10AB

22"
HD22AB-TF

20"
HD20AB-TF

18"
HD18AB-TF

16"
HD16AB-TF

14"
HD14AB-TF

12"
HD12AB-TF

10"
HD10AB-TF



1 SEA DRUMS

MEINL Sea Drums create the soothing sounds of the surf, with a great new feature: A sealable filling port allows you to control the amount of steel balls inside.

SIZES 16", 18", 20"
2 3/4" deep

MATERIALS Rubber Wood
(*Hevea brasiliensis* Muell.-Arg.)

Hand selected goat head and synthetic head
FD18SD-TF: True Feel synthetic head and transparent head

2 PLENERA SET

The Plenera is a traditional frame drum from Puerto Rico. The frames are made from rugged plastic and external mechanical lugs tune the hand selected goat-skin heads.

SIZES Quinto = 8"
Seguidor = 10"
Tumbador = 12"

MATERIALS ABS Plastic frames

Goatskin heads
FEATURE External mechanical lug tuning

MATERIALS

Hand selected buffalo head

Nylon lacing and grip

FEATURES

Warm and powerful sound

Adjustable hand grip

INCLUDES

Leather padded wooden beater

4 HAND DRUMS

Hand Drums are equipped with either the finest hand selected goat heads or with our synthetic True Feel heads. The scalloped frame guarantees a comfortable grip.

PANDEIROS

1



Napa head, 10"
PA10ABS-BK-NH

NAPA HEAD FOR REDUCED OVERTONES



Clear Mylar head, 10"
PA10ABS-BK



2



Goat head, 12"
PA12CN-M



Goat head, 10"
PA10CN-M

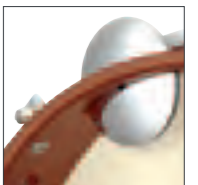

SOLID JINGLES

3



Goat head, 12"
PA12AB-M



Goat head, 10"
PA10AB-M

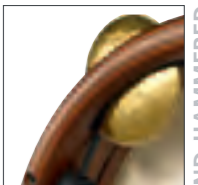

HAND-HAMMERED BRASS JINGLES

4



True Feel synthetic head, 12"
PAV12AB-M-TF



True Feel synthetic head, 10"
PAV10AB-M-TF

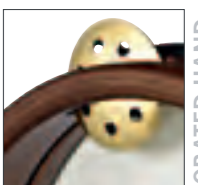

PERFORATED HAND-HAMMERED BRASS JINGLES

PANDEIROS

The Pandeiro is played with one hand while the other alters the pitch of the drum. MEINL Pandeiros are available with different jingle and head variations.

1 TRADITIONAL ABS PANDEIROS

SIZE 10"

MATERIALS ABS plastic

PA10ABS-BK: Replaceable synthetic head
PA10ABS-BK-NH: Replaceable Napa head

FEATURES Countersunk bolt lugs

2 TRADITIONAL WOOD PANDEIROS

SIZES 10", 12"

MATERIALS Rubber Wood

(*Hevea brasiliensis* Muell.-Arg.)

Replaceable hand selected goat heads

Countersunk bolt lugs

Chrome plated jingles and hardware

INCLUDES Tuning key

COLOUR **CN-M:** Chest Nut, matte

3 SHELL-TUNED GOAT SKIN PANDEIROS

INCLUDES Allen wrench

COLOUR **AB-M:** African Brown, matte

4 SHELL-TUNED SYNTHETIC HEAD PANDEIROS

SIZES 10", 12"

MATERIALS Rubber Wood

(*Hevea brasiliensis* Muell.-Arg.)

True Feel synthetic head

FEATURES Perforated hand-hammered brass jingles for extra dry sound

Internal lug tuning system

TAMBOURINES

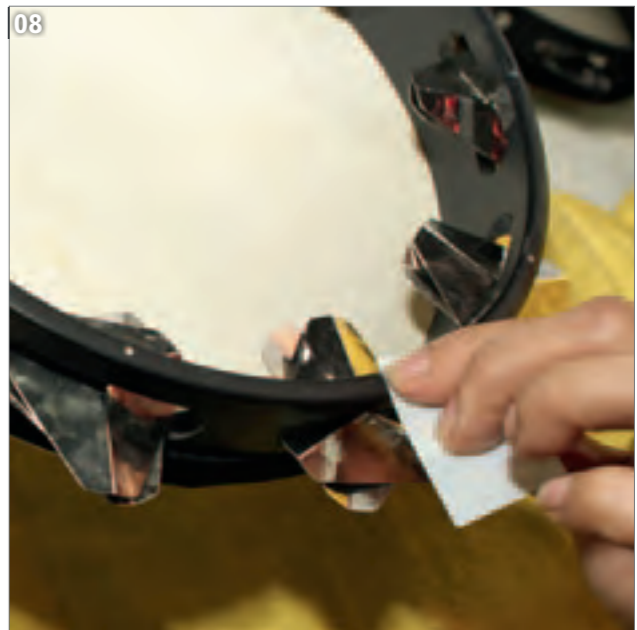
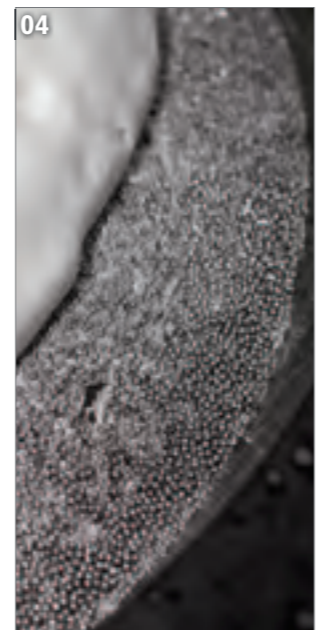
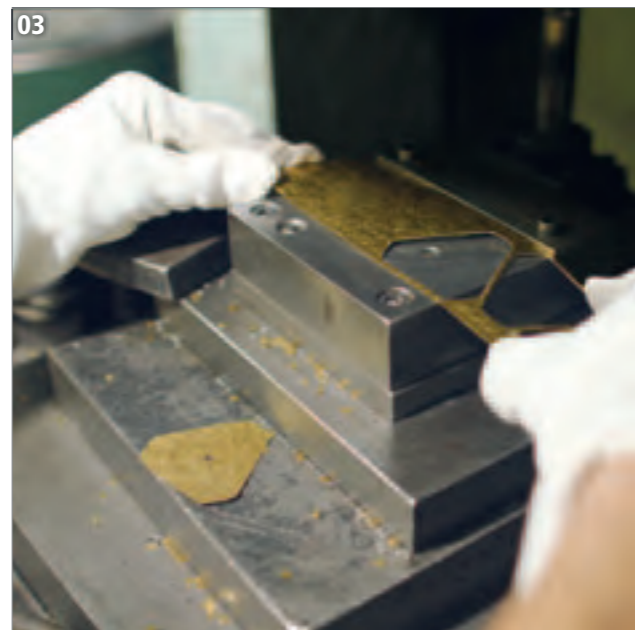
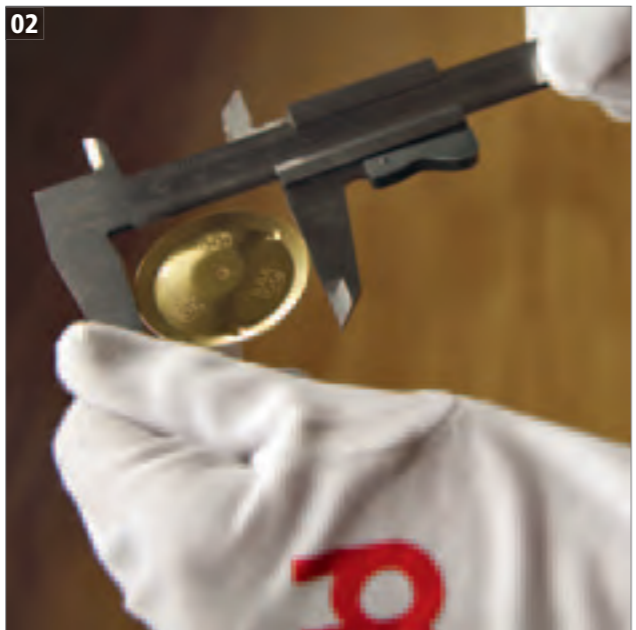

LOGO APPLIED WITH HOT IRON BRAND ON OUR ARTISAN EDITION TAMBOURINES.

- 01** Forming the jingles.
- 02** Our jingles are precision made.
- 03** A brass super dry jingle is cut from the stock sheet.
- 04** The jingles are polished in a special bath with metal beads.
- 05** Every jingle has to be carefully checked before it can be mounted on a frame.
- 06** The jingle slots of this 2 row tambourine are being sanded.
- 07** The tambourines are assembled by hand.
- 08** The nails are also secured with glue.



HEADED WOOD TAMBOURINES

1



1 row
TAH1AB

2 rows
TAH2AB

NICKELSILVER
PLATED STEEL

2



1 row
TAH1A-AB

2 rows
TAH2A-AB

ALUMINUM

3



1 row
TAH1M-SNT

2 rows
TAH2M-SNT

STEEL / SOLID BRASS

4



1 row
TAH1B-AB

2 rows
TAH2B-AB

SOLID BRASS

HEADED WOOD TAMBOURINES
MEINL's Headed Wood Tambourines are made from a sturdy frame with jingles available in different materials, resulting in various sound possibilities. Each head is hand selected to provide best quality on these pre-tuned drums.

1 TRADITIONAL GOAT-SKIN WOOD TAMBOURINES, STEEL JINGLES
SIZE 10"
MATERIALS Nickelsilver plated steel
Hand selected goat heads
Wooden frame
FEATURE 1 row and 2 row version
COLOUR **AB**: African Brown

2 TRADITIONAL GOAT-SKIN WOOD TAMBOURINES, ALUMINUM JINGLES
SIZE 10"
MATERIALS Aluminum
Hand selected goat heads
Wooden frame
FEATURE 1 row and 2 row version
COLOUR **AB**: African Brown

3 RECORDING-COMBO GOAT-SKIN WOOD TAMBOURINES, DUAL-ALLOY JINGLES
SIZE 10"
MATERIALS Steel / Solid brass
Hand selected goat heads
Wooden frame
FEATURES Dual-alloy jingles
1 row and 2 row version
COLOUR **SNT**: Super Natural

4 TRADITIONAL GOAT-SKIN WOOD TAMBOURINES, BRASS JINGLES
SIZE 10"
MATERIALS Solid brass
Hand selected goat heads
Wooden frame
FEATURE 1 row and 2 row version
COLOUR **AB**: African Brown

5 NEW!



1 row
TAH1V-WB

2 rows
TAH2V-WB

HAMMERED BRASS

6



1 row
TAH1BK-R-TF

2 rows
TAH2BK-R-TF

BLACK PLATED STEEL

7



1 row
STAH1S-BK

2 rows
STAH2S-BK

HAND-HAMMERED
STAINLESS STEEL

8



1 row
STAH1B-BK

2 rows
STAH2B-BK

HAND-HAMMERED
BRASS

5 VINTAGE GOAT SKIN WOOD TAMBOURINES
MEINL is bringing the old school tambourines back! The special designed jingles produce the legendary sound that was familiar a long time ago. These tambourines are equipped with the best quality goatskin head.
SIZE 10"
MATERIALS Hammered Brass
Hand selected goat heads
Wooden frame
FEATURES 1 Row and 2 row version
Legendary tambourine sound
Special profile jingles
Detailed with hot-branded logo
COLOUR **WB**: Walnut Brown

6 TOURING SYNTHETIC HEAD WOOD TAMBOURINES
SIZE 10"
MATERIALS Black plated steel
True Feel synthetic head
Wooden frame
FEATURES 1 Row and 2 row version
True Feel synthetic head
COLOUR **R**: Red

7 SUPER-DRY STUDIO GOAT SKIN WOOD TAMBOURINES, STAINLESS STEEL JINGLES
SIZE 10"
MATERIALS Hand-hammered stainless steel
Hand selected goat heads
Wooden Frame

FEATURES Hand-hammered triangular jingles for an extra sweet sound with short sustain
1 row and 2 row versions
COLOUR **BK**: Black

8 SUPER-DRY STUDIO GOAT SKIN WOOD TAMBOURINES, BRASS JINGLES
SIZE 10"
MATERIALS Hand-hammered brass
Hand selected goat heads
Wooden frame
FEATURES Hand-hammered triangular brass jingles for extra dry sound
1 row and 2 row version
COLOUR **BK**: Black



1 row **TA1AB**
2 rows **TA2AB**

NICKELSILVER PLATED STEEL

ALUMINUM

1 row **TA1A-AB**
2 rows **TA2A-AB**



1 row **TA1M-SNT**
2 rows **TA2M-SNT**

STEEL / SOLID BRASS

SOLID BRASS

1 row **TA1B-AB**
2 rows **TA2B-AB**



1 row **TA1V-WB**
2 rows **TA2V-WB**

NEW!

HAMMERED BRASS



1 row **STA1S-BK**
2 rows **STA2S-BK**

HAND-HAMMERED STAINLESS STEEL

HAND-HAMMERED BRASS

1 row **STA1B-BK**
2 rows **STA2B-BK**

WOOD TAMBOURINES
MEINL's Wood Tambourines are made from a sturdy frame with jingles available in different materials, resulting in various sound possibilities. Their ergonomically shaped handle and light weight enable energetic playing.

1 TRADITIONAL WOOD TAMBOURINES, STEEL JINGLES
SIZE 10"
MATERIALS Nickelsilver plated steel
Wooden frame
FEATURE 1 row and 2 row version
COLOUR **AB**: African Brown

2 TRADITIONAL WOOD TAMBOURINES, ALUMINUM JINGLES
SIZE 10"
MATERIALS Aluminum
Wooden frame
FEATURE 1 row and 2 row version
COLOUR **AB**: African Brown

3 RECORDING-COMBO WOOD TAMBOURINES, DUAL-ALLOY JINGLES
SIZE 10"
MATERIALS Steel / solid brass
Wooden frame
FEATURES Dual-alloy jingles
1 row and 2 row version
COLOUR **SNT**: Super Natural

4 TRADITIONAL WOOD TAMBOURINES, BRASS JINGLES
SIZE 10"
MATERIALS Solid brass
Wooden frame
FEATURE 1 row and 2 row version
COLOUR **AB**: African Brown

5 VINTAGE WOOD TAMBOURINES
MEINL is bringing the old school tambourines back! The special designed jingles produce the legendary sound that was familiar a long time ago. Combined with a discreet and classy look these tambourines will make every percussionist proud.
SIZE 10"
MATERIALS Hammered brass
Wooden frame
FEATURES Legendary tambourine sound
Special profile jingles
Detailed with hot-branded logo
COLOUR **WB**: Walnut Brown

6 SUPER-DRY STUDIO WOOD TAMBOURINES, STAINLESS STEEL JINGLES
SIZE 10"
MATERIALS Hand-hammered stainless steel
Wooden Frame
FEATURES Hand-hammered triangular jingles for an extra sweet sound with short sustain
1 row and 2 row versions
COLOUR **BK**: Black

7 SUPER-DRY STUDIO WOOD TAMBOURINES, BRASS JINGLES
SIZE 10"
MATERIALS Hand-hammered brass
Wooden frame
FEATURES Hand-hammered triangular brass jingles for extra dry sound
1 row and 2 row version
COLOUR **BK**: Black

1 NEW!



SOLID BRASS

HOW WE MAKE IT

- 01 Preparing the head for the Resin powder.
- 02 Putting a layer Resin on the head to enable special playing techniques.



2 rows
AE-MTAH2B

NEW!



CYMBAL BRONZE



2 rows
AE-MTAH2BO

TOTAL UNIQUE TAMBOURINE SOUNDS

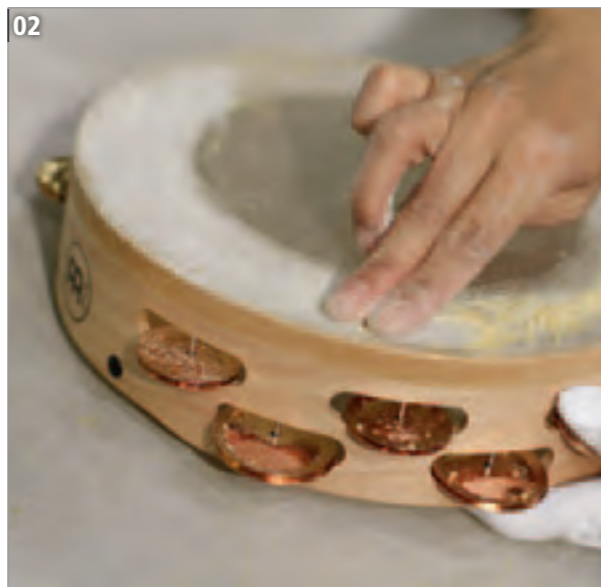

1 HEADED ARTISAN EDITION TAMBOURINES
The MEINL Headed Artisan Edition Tambourines come with a hand selected calf skin head featuring an outer ring that is prepared with Resin for special playing techniques like thumb rolls. Two different jingle versions (size and design) placed in a staggered arrangement ensure a wide sound spectrum from piano to forte and a consistent jingle sound when performing rolls.

- SIZE 10"
- MATERIALS Maple (*Adcer sp.*)
Hand selected calf head
- B:** Solid brass
- BO:** Cymbal bronze

- FEATURES Total unique tambourine sounds
- Two different profile jingles
- Ergonomic hand grip
- Detailed with ornamental hot-branded logo
- Prepared with Resin



TWO DIFFERENT PROFILE JINGLES



KONRAD GRAF, GERMANY

2



SOLID BRASS



1 row
AE-MTA1B



GERMAN CYMBAL BRONZE



1 rows
AE-MTA1BO

2 rows
AE-MTA2BO



3 NEW!



HAMMERED BRASS



3 rows
AE-CMTA3B

NEW!



HAMMERED CYMBAL BRONZE



3 rows
AE-CMTA3BO

COMPACT TAMBOURINE IN HANDY SIZE

2 ARTISAN EDITION TAMBOURINES
MEINL Artisan Edition Tambourines are proudly made for the most discerning musicians. We developed a special profile jingle for a fine and distinct sound. The attack is airy yet punctuated, with a medium sustain. Artisan frames are precision made from pure maple wood. The hand grip is comfortable and secure.

- SIZE 10"
- MATERIALS Maple (*Adcer sp.*)
- B:** Solid brass
- BO:** Cymbal bronze
- FEATURES Total unique tambourine sounds
- Special profile jingles
- Ergonomic hand grip
- Detailed with ornamental hot-branded logo

3 ARTISAN EDITION COMPACT TAMBOURINES
The popular MEINL Artisan Edition Tambourines now come in a compact presentation. The size of this maple shell is 8 inches and features 3 rows of jingles with the option of solid brass jingles or German cymbal bronze jingles. The narrow jingle slots will ensure accuracy and precision when you need it.

- SIZE 8"
- MATERIALS Maple (*Adcer sp.*)
- B:** Hammered brass
- BO:** Hammered cymbal bronze
- FEATURES Total unique tambourine sounds
- Special profile jingles
- Ergonomic hand grip
- Detailed with ornamental hot-branded logo
- 3 rows of jingles
- Extra narrow jingle slots for precise playing



LARRY SALZMAN, USA



COMPACT WOOD TAMBOURINES

HAND HELD ABS TAMBOURINES

TAMBOURINES



2 rows
CTA2S-BK

2 rows
CTA2M-BK

2 rows
CTA2B-BK



2 rows
CSTA2S-BK

2 rows
CSTA2B-BK

THE HAND-HAMMERED JINGLES BRING A TRASHY FLAVOUR TO YOUR RHYTHM



TMT1BK

TMT1R

TMT1A-WH

TMT1A-B

TMT1M-WH

TMT1B-BK

STMT1S-BK

STMT1B-BK

COMPACT WOOD TAMBOURINES
 Good sounds comes in small packages! MEINL Percussion offers a great line of Compact Wood Tambourines. Light, fast, and full of sound, they are available in five different versions.

SIZE 8"

MATERIALS Wooden frame
CTA2S-BK: Steel
CTA2M-BK: Steel / solid brass
CTA2B-BK: Solid brass
CSTA2S-BK: Hand-hammered stainless steel
CSTA2B-BK: Hand-hammered brass

FEATURES Compact size
 Many jingle variations

COLOUR **BK:** Black

SEE THE DIFFERENCE !!!

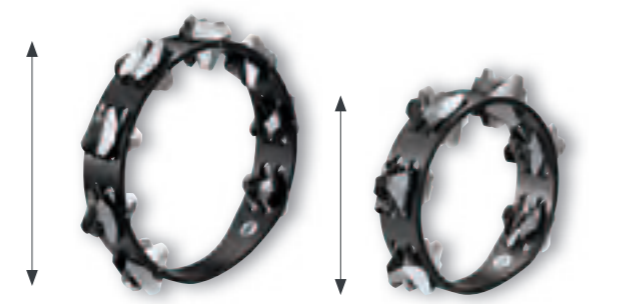

Regular tambourine size 10", 16 pairs of jingles!
 Compact tambourine in handy size 8", 12 pairs of jingles!

THE 8" DIAMETER MAKES THEM VERY COMPACT AND HANDY

HAND HELD ABS TAMBOURINES
 The MEINL hand held ABS Tambourines come with a padded ergonomic soft grip and are extremely light weight for long term playing comfort. Several jingle variations offer sounds ranging from dry and cutting to sweet and soft, helping every drummer find the right flavor for their rhythms.

FEATURES Padded soft grip for more playing comfort
 Ergonomic design
 Guiro style playing surface
 "Sandwich" construction

1 TRADITIONAL TAMBOURINES, STEEL JINGLES
MATERIALS Nickelsilver plated steel
 ABS plastic
COLOURS **BK:** Black
R: Red

2 TRADITIONAL ABS TAMBOURINES, ALUMINUM JINGLES
MATERIALS Aluminum
 ABS plastic
COLOURS **B:** Blue
WH: White

3 RECORDING-COMBO ABS TAMBOURINE, DUAL-ALLOY JINGLES
MATERIALS Nickelsilver plated steel and solid brass
 ABS plastic
COLOUR **WH:** White

4 TRADITIONAL ABS TAMBOURINE, BRASS JINGLES
MATERIALS Solid brass
 ABS plastic
COLOUR **BK:** Black

5 SUPER DRY STUDIO ABS TAMBOURINE, STAINLESS STEEL JINGLES
MATERIALS Hand-hammered stainless steel
 ABS plastic body
COLOUR **BK:** Black

6 SUPER DRY STUDIO ABS TAMBOURINE, BRASS JINGLES
MATERIALS Hand-hammered brass
 ABS plastic body
COLOUR **BK:** Black



MAKE YOUR HATS GO CHING

KJ Sawka (Pendulum) uses a Professional Hihat Tambourine for special accents.



CHRIS COLEMAN, USA



JEAN PAUL GASTER, USA



TREVOR LAWRENCE JR., USA



NORMAN BONINK, NETHERLANDS



FLO DAUNER, GERMANY



THOMAS LANG, AUSTRIA





MOUNTABLE ABS TAMBOURINES

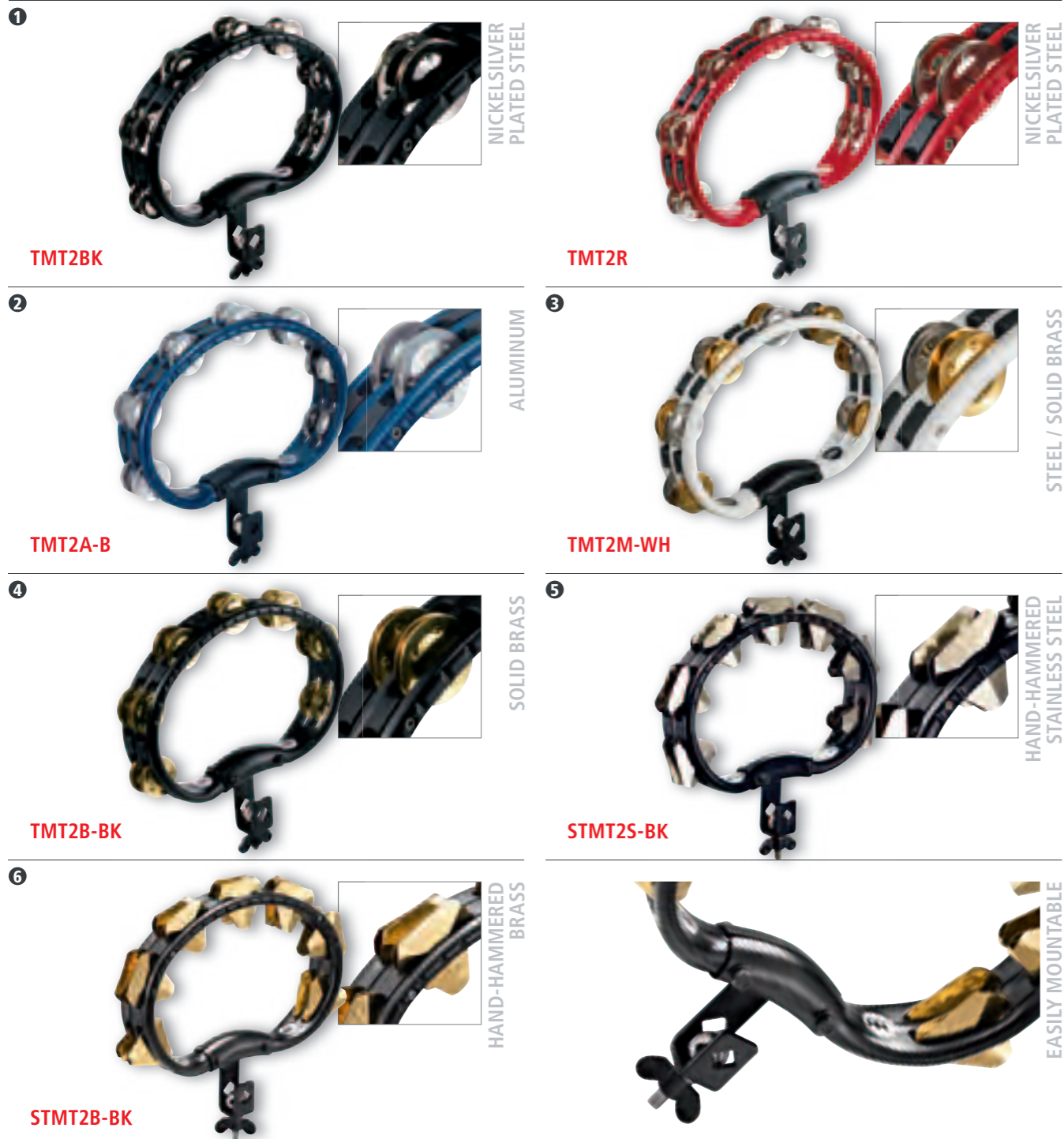

MOUNTABLE ABS TAMBOURINES
The MEINL mountable ABS Tambourines are built to stand up to the heaviest of hitters. They are easily mounted on a rod or stand to complete a drummer's setup. Several jingle variations offer sounds ranging from dry and cutting to sweet and soft, helping every drummer find the right flavor for their rhythms.

FEATURES Easily mountable
Ergonomic design
Güiro style playing surface
"Sandwich" construction

1 TRADITIONAL ABS TAMBOURINES, STEEL JINGLES
MATERIALS Nickelsilver plated steel
ABS plastic
COLOURS **BK:** Black
R: Red

2 TRADITIONAL ABS TAMBOURINE, ALUMINUM JINGLES
MATERIALS Aluminum
ABS plastic
COLOUR **B:** Blue

3 RECORDING-COMBO ABS TAMBOURINE, DUAL-ALLOY JINGLES
MATERIALS Steel / solid brass
ABS plastic
COLOUR **WH:** White

4 TRADITIONAL ABS TAMBOURINE, BRASS JINGLES
MATERIALS Solid brass
ABS plastic
COLOUR **BK:** Black

5 SUPER-DRY ABS STUDIO TAMBOURINE, STAINLESS STEEL JINGLES
MATERIALS Hand-hammered stainless steel
ABS plastic
COLOUR **BK:** Black

6 SUPER DRY STUDIO ABS TAMBOURINE, BRASS JINGLES
MATERIALS Hand-hammered brass
ABS plastic body
COLOUR **BK:** Black

HIHAT TAMBOURINES & JINGLE STICKS

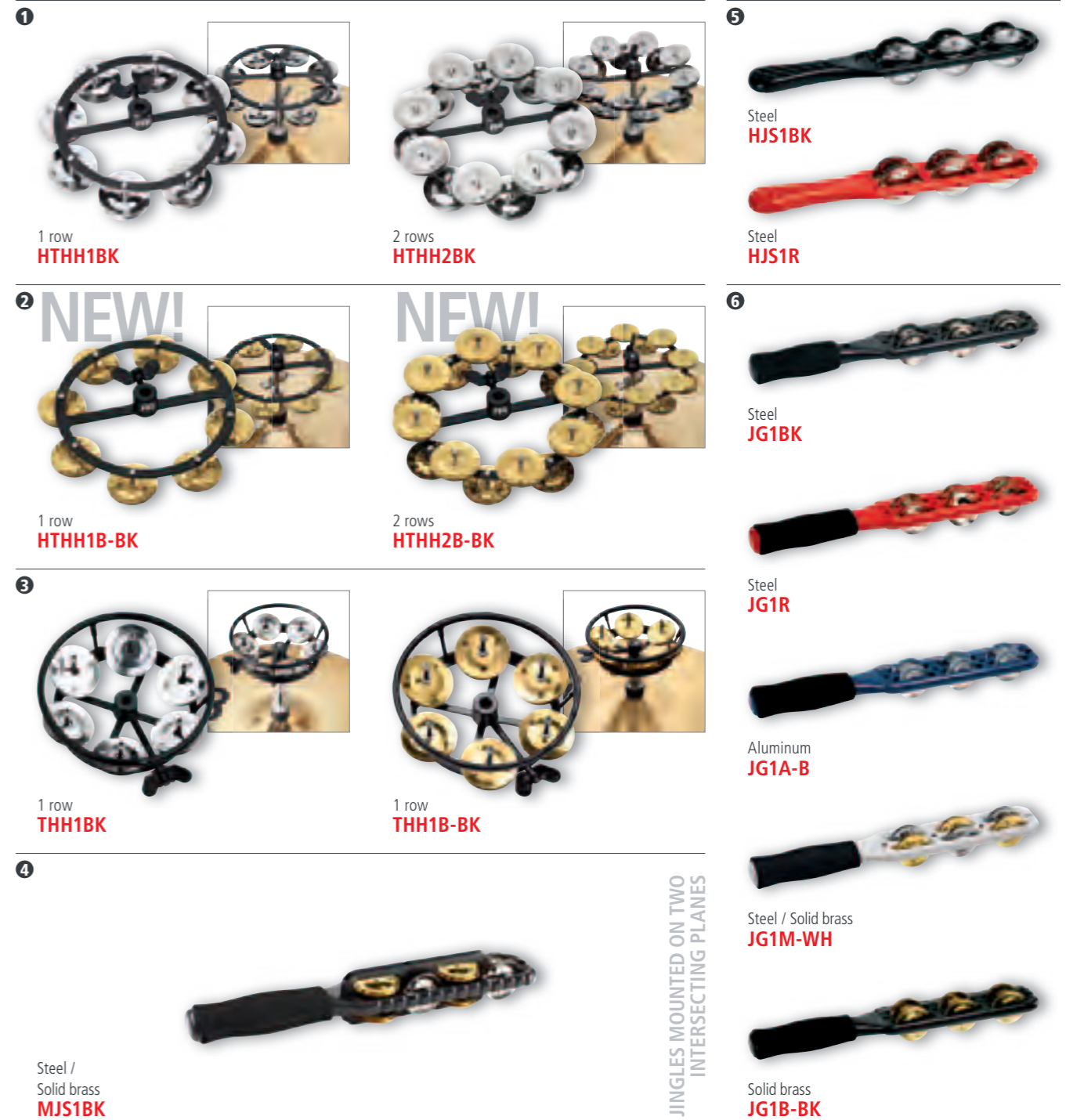

HIHAT TAMBOURINES 1 2 3
An easy access wing nut allows quick set-up, adjustment, or removal, completely independent from your cymbals. The Professional Hihat Tambourines feature a sturdy rubberized striking ring for special accents.
SIZE 5"

1 HEADLINER® SERIES HIHAT TAMBOURINES
MATERIAL Steel

2 HEADLINER® SERIES HIHAT TAMBOURINES
MATERIAL Hammered brass

3 PROFESSIONAL SERIES HIHAT TAMBOURINES
MATERIALS **THH1BK:** Steel
THH1B-BK: Solid brass
FEATURE Rubber padded surface

4 MULTI-JINGLE STICK
The MEINL Multi-Jingle Stick steps out into a new dimension. Steel and solid brass jingles are mounted on two intersecting faces and a single handle, for multi-directional dynamics. This opens up many new combinations of movement and sound.

MATERIALS ABS plastic
Steel and solid brass
FEATURES Jingles mounted on two intersecting planes
Padded grip
Special playing techniques

5 HEADLINER® SERIES JINGLE STICKS
The MEINL Headliner® Series Jingle Sticks are an affordable alternative to a tambourine. Nice sound effects are also achieved when used as a stick on a drum.

MATERIALS Nickelsilver plated steel
ABS plastic
COLOURS **BK:** Black
R: Red

6 PROFESSIONAL SERIES JINGLE STICKS
The MEINL Professional Jingle Sticks create many interesting sound possibilities.
MATERIALS ABS plastic
JG1: Nickelsilver plated steel
JG1A: Aluminum
JG1M: Steel solid brass
JG1B: Solid brass

FEATURES Padded grip
Güiro style playing surface

TAMBOURINES

COWBELLS

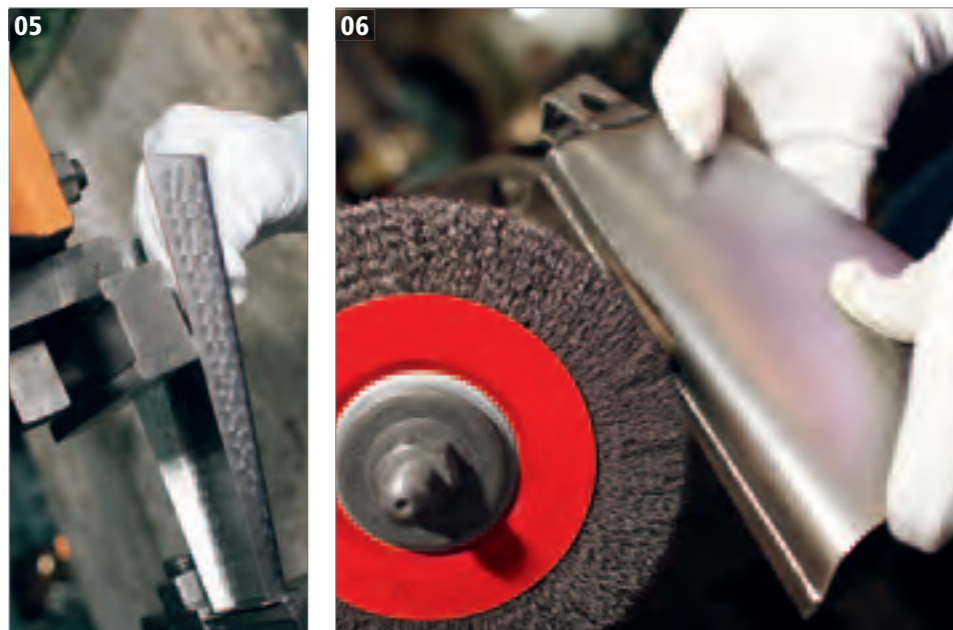
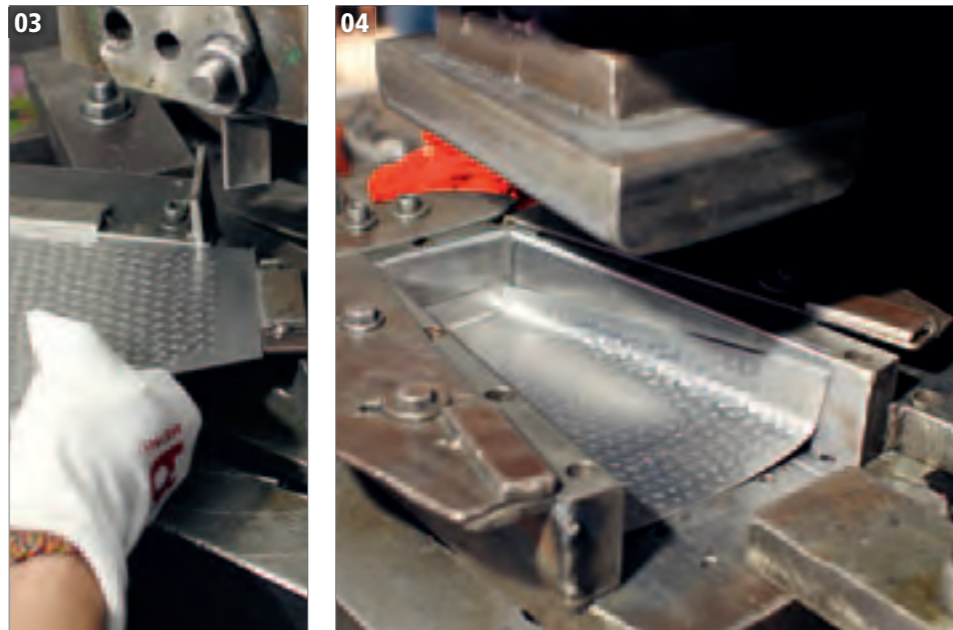
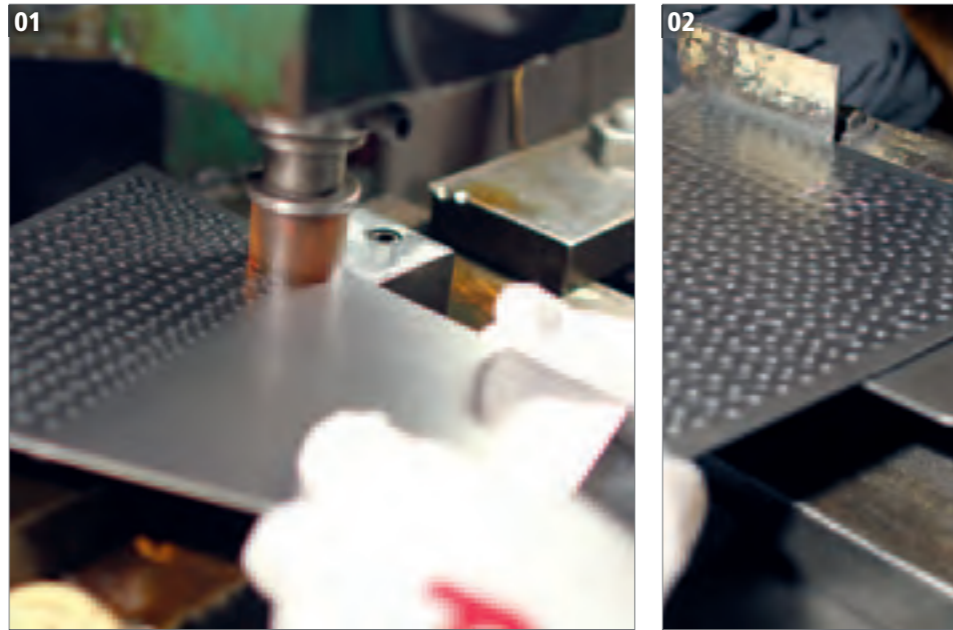

01 Cowbells are made in two halves. Here you see one side getting its hammered texture for an extra dry sound.

02 The MEINL logo is then stamped in the proper place.

03 The corners have to be cut out so the flat blank can be shaped into a cowbell.

04 A press forms the bell halves into shape.

05 Excess material is trimmed away.

06 The welds are brushed clean in preparation for the finish.



WE USE A DEEP PENETRATING AUTOMATIC FEED WELDING PROCESS FOR A SUPER STRONG SEAM.

1



8" big mouth
RM80B

ADJUSTABLE INTERIOR
DAMPENING MECHANISM



RUSS MILLER, USA

2



8" small mouth
KA80S



6 1/4"
KA625



KENNY ARONOFF, USA

3



8" big mouth
STB80BHH-G



6 1/4"
STB625HH-G

HAND BRUSHED GOLD



8" big mouth
STB80BHH-S

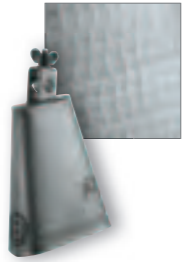

6 1/4"
STB625HH-S

HAND BRUSHED STEEL



8" big mouth
STB80BHH-C



6 1/4"
STB625HH-C

HAND BRUSHED COPPER

4



8" big mouth
STB80B-CH



8" small mouth
STB80S-CH



6 1/4"
STB625-CH



5 1/2"
STB55-CH



4 1/2" low pitch
STB45L-CH



HIGH POLISHED CHROME

5



8" big mouth
STB80B



8" small mouth
STB80S



6 1/4"
STB625



5 1/2"
STB55



4 1/2" high pitch
STB45H



4 1/2" medium pitch
STB45M



4 1/2" low pitch
STB45L

HAND BRUSHED STEEL

6



8 1/2"
SL850-BK



6 3/4"
SL675-BK



5 1/4"
SL525-BK



4 3/4"
SL475-BK



RODNEY HOLMES, USA

7



2 1/2", 3 1/2", 5"
SLTRI-BK



EASY MOUNTABLE

8



HAM1BK

EASY MOUNTABLE

9



8"
HCO2BK



5"
HCO4BK



BLACK POWDER
COATED STEEL

10



High pitch
MPE1BK



Low pitch
MPE2R

11



8.15"
STB815H



7.85"
STB785H



6.5"
STB65H

SPECIAL STEEL ALLOY

12



6 1/4"
STB625HA-CB



4 1/2"
STB45HA-CB



COMFORTABLE HOLDER

1 ARTIST SERIES COWBELL (RUSS MILLER)

The Russ Miller "Multi-Bell" enables multiple tones and is a breakthrough in versatility. You can adjust the amount of ring to your desired level with just a turn of a knob. This innovation brings out the most in a cowbell!

MATERIAL Special steel alloy

FEATURES Adjustable interior dampening mechanism
Hammered

FINISH Hand brushed black

2 ARTIST SERIES COWBELLS (KENNY ARONOFF)

Kenny Aronoff says: "my signature cowbells are the ultimate drummer's bells. Playing live they cut through and have very nice tones. Their recording characteristics are outstanding, too."

MATERIAL Special steel alloy

FEATURE Hammered

FINISH High polished chrome

3 HAMMERED COWBELLS

The strong fundamental tone of these cowbells make them a unique alternative to all other bells on the market. Each bell has its own character.

MATERIAL Special steel alloy

FEATURE Hammered

FINISHES Hand brushed copper, gold & steel

4 5 CHROME & STEEL FINISH COWBELLS

The pitches of these cowbells form a diatonic scale which makes it easy to use multiple bell combinations in any musical setting.

MATERIAL Special steel alloy

FEATURE Tonally matched

FINISHES **CH**: High polished chrome

Hand brushed steel

6 7 BLACK FINISH COWBELLS & TRIPLE BELL

Their black powder coated steel produces a firm muffled sound.

MATERIAL Special steel alloy

FEATURE Muffled sound

FINISH Black powder coated steel

8 HANDMATE

The MEINL Handmate is a professional cowbell beater which can be mounted in a set-up. This allows hitting the cowbell by hand while playing another instrument.

MATERIAL Steel construction with a wooden ball

FEATURE Fully adjustable

9 HEADLINER® SERIES COWBELLS

Made from black powder coated steel, the MEINL Headliner® Series Cowbells produce a cutting and sharp sound. Whether used in a percussion setup or

in a drum set configuration, they always add a special flavour to your groove.

MATERIAL Black powder coated steel

COLOUR **BK**: Black

10 PERCUSSION BLOCKS

The MEINL Percussion Blocks are made to withstand even the hardest hitting players.

MATERIAL PE

FEATURES **MPE1BK**:

High pitched sound and durability

MPE2R:

Low pitched sound and durability

INCLUDES Mounting Clamp

COLOURS **BK**: Black

R: Red

11 HAND COWBELLS

These cowbells easily cut through any high volume environment and are comfortable to hold due to their handy shape.

MATERIAL Special steel alloy

FINISH Hand brushed steel

12 HANDHELD COWBELLS

The unique feature of the MEINL Handheld Models is a wide and comfortable grip. Ideal for street percussion.

MATERIAL Special steel alloy

FEATURE Comfortable holder

FINISH Hand brushed steel

BILL SARAGOSA LINE



BILL SARAGOSA, NOT FROM THIS WORLD



1 CONE



2 BOWL



3 TRIL

FILLED WITH WATER



4 GALAXY

VERY FUNKY



5 CRASHER

NEW!
INVENTOR: MARCUS RALPH DE MOWBRAY



6 27 bells BT27



7 14 bells BT14



Large (low pitch) **WW2BK**

Small (high pitch) **WW1BK**

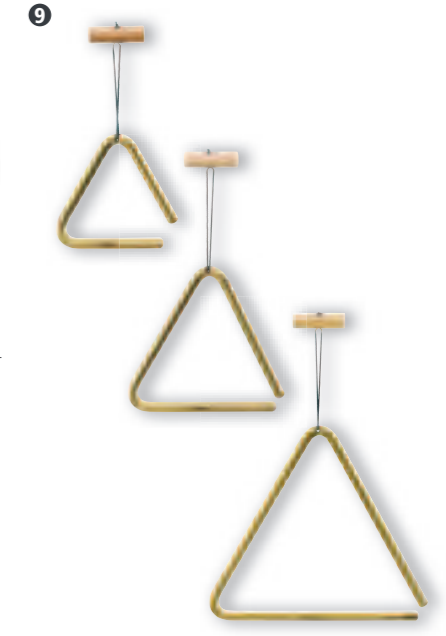

4" **TRI10B**

6" **TRI15B**

8" **TRI20B**



10 7" JCTRI20

INVENTOR: JOSÉ J. CORTIJO



11 PFICY-2



12 FICY-2



13 FICY-14

MARCIE CHAPA, USA

SPECIAL BRONZE ALLOY

BILL SARAGOSA LINE 1 2 3 4
Instruments created by Bill Saragosa are very unique.
MATERIAL Special steel alloy
FEATURE Wide sound spectrum
FINISH Black nickel

- 1 CONE-STACK**
FEATURE A set of two
- 2 HELIX BOWL (US patent)**
INCLUDES Metal beater
- 3 LIQUID TRIANGLE**
INCLUDES Metal beater
- 4 GALAXY**
INCLUDES Metal beater

5 TURBO CRASHER
The new MEINL Turbo Crasher will be a must for drummers and percussionists of all genres who want to add a different colour to their set up. This percussion accessory can be placed on any rod and will give you a nice short crashing sound.

MATERIAL Steel
FEATURES Güiro style playing surface
Cutting sound
Easy mountable

6 STAND ALONE BELL TREE
The MEINL Bell Tree has 27 solid brass bells mounted on a sturdy metal stand.
MATERIAL Solid brass bells
FEATURE Adjustable metal stand
INCLUDES Striker

7 HAND HELD BELL TREE
Our Hand Held Bell Tree has a cascade of 14 solid brass bells securely mounted on a wooden handle.
MATERIAL Solid brass bells
INCLUDES Striker

8 WAH-WAH TUBES
The MEINL Wah-Wah Tube is a tubular effect instrument that delivers smooth, bell like tones.
SIZES Small (high pitch)
Large (low pitch)
MATERIAL Aluminum
INCLUDES Rubber mallet
COLOUR **BK:** Black

9 TRIANGLES
The solid brass triangles produce a nice sounding soft tone with a controlled sonic spectrum.
SIZES 4", 6", 8"
MATERIAL Solid brass
INCLUDES Wooden holder with braided nylon cord
Metal beater

10 ARTIST SERIES UNIVERSAL TRIANGLE (JOSÉ J. CORTIJO)
The Universal Triangle is forged from one single piece of steel with a special texture for rasping effects.
SIZE 7"
MATERIAL Chrome plated steel
FEATURES Inner section for multiple tones
Textured leg for rasping strokes
INCLUDES Wooden holder with braided nylon cord
Metal beater

11 PROFESSIONAL FINGER CYMBALS
Made from a special bronze alloy and attached with a durable cord.
SIZE 2 5/8" diameter
MATERIAL Special bronze alloy
FEATURES Identical, high pitched sound
Durable cord

12 ORIENTAL FINGER CYMBALS
Measuring 2 3/8" in diameter, they are easy to hold and comfortable to play.
SIZE 2 3/8" diameter
MATERIAL Special bronze alloy
FEATURES Identical in pitch
Durable rubber band connection

13 HANGING FINGER CYMBALS
Strung on a durable cord and made from a special bronze alloy, 14 unique finger cymbals produce a shimmering chorus effect.
SIZE 2 3/8" diameter
MATERIAL Special bronze alloy
FEATURES Durable cord and shimmering sound



HIGH FREQUENCY CHIME

60 bars, double row
LC60HF



LUIS CONTE, USA



ALL BARS ARE ATTACHED THROUGH A NYLON CORD

66 bars, double row
CH66HF



HIGH FREQUENCY CHIME

33 bars, single row
CH33HF



27 bars
CH27VWB



33 bars
CH33VWB



27 bars
HCH1R



33 bars
HCH2BK

SILVER ANODIZED ALUMINUM ALLOY



12 bars, single row
CH12



27 bars, single row
CH27ST



27 bars, single row
CH27



12 bars **CH-H12** 18 bars **CH-H18** 24 bars **CH-H24**



12 pegs
CH-HPEG



CH3

MEINL Chimes provide great tonal effect and are available in a wide assortment of sounds. All MEINL Chimes are made from a premium anodized aluminum alloy, and a well balanced wooden bar. Durable nylon cord is used to hang them securely.

1 ARTIST SERIES CHIMES (LUIS CONTE)
"I wanted a wide spectrum!" comments Luis Conte. "The shorter bars deliver great high pitched sounds. I can get a full and bright chime sound from the medium and low pitched bars. They sound perfect especially in the studio."
SIZE 60 bars, double row
MATERIAL Silver anodized aluminum alloy
FEATURE High frequency chime
INCLUDES Holder
Striker
COLOUR Green

2 CHIMES, 66 BARS
The 66 bar chimes produce a rich and full sound. They cut through any band setting.
SIZE 66 bars, double row
MATERIAL Gold anodized aluminum alloy
FEATURE High frequency chime
INCLUDES Holder
Striker

3 CHIMES, 33 BARS
The 33 bar chimes produce a very bright sound with a pronounced upper overtone spectrum. They are perfect for all live situations.
SIZE 33 bars, single row
MATERIAL Gold anodized aluminum alloy
FEATURE High frequency chime
INCLUDES Holder
Striker

4 VINTAGE CHIMES, 27 BARS
The 27 bar Vintage Chimes is an excellent addition to any drum or percussion arrangement.
SIZE 27 bars, single row
MATERIAL Silver anodized aluminum alloy
COLOUR **VWB:** Vintage Wine Barrel

5 VINTAGE CHIMES, 33 BARS
The 33 bar Vintage Chimes can be used in a wide range of musical styles, producing a sweet sparkling sound.
SIZE 33 bars, single row
MATERIAL Silver anodized aluminum alloy
INCLUDES Holder
Striker
COLOUR **VWB:** Vintage Wine Barrel

6 HEADLINER® SERIES CHIMES, 27 BARS
The MEINL Headliner® Series Chimes are a great and affordable addition to any percussion set-up! They are made from high quality materials and produce a full and warm chime sound.
SIZE 27 bars
MATERIAL Silver anodized aluminum alloy
COLOUR **R:** Red

7 HEADLINER® SERIES CHIMES, 33 BARS
This chime has 33 silver-anodized bars for a full sound spectrum. The curved black truss beam and the silver bar chimes look great in any percussion setup.
SIZE 33 bars
MATERIAL Silver anodized aluminum alloy
COLOUR **BK:** Black

8 CHIMES, 12 BARS
The 12 bar chimes produce a beautiful, high pitched sound. Not too obtrusive, ideal for tasteful chime accents.
SIZE 12 bars, single row
MATERIAL Gold anodized aluminum alloy

9 STUDIO CHIMES, 27 BARS
The Studio Chimes feature slightly thinner bars for a full, rich and delicate sound.
SIZE 27 bars, single row
MATERIAL Gold anodized aluminum alloy

10 CHIMES, 27 BARS
The 27 bar chimes produce a full sound with a wide tonal spectrum. Ideal for smaller stages and club scenes.
SIZE 27 bars, single row
MATERIAL Gold anodized aluminum alloy

11 HAND CHIMES
The three models of hand chimes are tonally matched.
SIZES 12 bars, 18 bars, 24 bars
MATERIAL Gold anodized aluminum alloy

12 PEG CHIMES
The Peg Chimes are extremely high pitched. They are perfect for special accents.
SIZE 12 pegs
MATERIAL Gold plated steel

13 TRI TONE CHIMES
The three free-floating bars create a very long sustain and are tonally matched.
MATERIAL Gold anodized aluminum alloy
FEATURE Mountable on all common L-rods
INCLUDES Wooden beater and holder

MEINL CABASAS, SLEIGH BELLS, GÜIRAS & BLOCKS

1  **CA7R**
ADJUSTABLE NET FOR VARIOUS TENSIONS AND SOUND OPTIONS

2  **CA5BK-L** **CA5BK** **CA5BK-S**
PORTS FOR MORE VOLUME (PATENTED)

3  **SLB25** **SLB12** **SLB7**
STEEL BELLS

4 **NEW!**  **MGU2** **MGU1**
COMES WITH SCRAPER



5  **PMWB1-L** **PMWB1-M**
WELL DEFINED FUNDAMENTAL SOUND

6  **MWB2BK** **MWB1BK**
ROUNDED PLAYING SURFACE

1 CABASA, FIBERGLASS
The shape and function of the MEINL Fiberglass Cabasa equals a traditional gourd calabash.
MATERIAL Premium fiberglass
COLOUR **R**: Red

2 TURBO CABASAS (PATENTED)
The MEINL Turbo Cabasas are a great innovation, with significantly more volume than normal cabasas.
SIZES Small, medium, large
MATERIALS Steel chain and stainless steel cylinder
Wooden handle with padded soft grip
FEATURE 5 sound ports on each side for more volume (CN, DE, US patent)
COLOUR **BK**: Black

3 SLEIGH BELLS
The MEINL Sleigh Bells ring rich and full, for a true sleigh bell sound. A positive, ergonomic grip assures dynamic control.
SIZES 7, 12, 25 bells
MATERIALS Steel bells
Wooden handle
FEATURES Ergonomic grip
True sleigh bell sound

4 MERENGUE GÜIRAS
Our Merengue Güiras are robust with a precision-formed scraping surface.
SIZES Small, Large
MATERIAL Brushed steel
FEATURES Scraping surface with uniform raised bumps
One-piece metal grip with welded flanges
INCLUDES Scraper

5 PROFESSIONAL WOOD BLOCKS
Our Professional Wood Blocks are topped with Rosewood for a sharp, well defined fundamental sound.
SIZES Medium, Large
MATERIALS Rosewood top
Rubberwood body
(*Hevea brasiliensis* Muell.-Arg.)
FEATURES Well defined fundamental sound
FINISH Natural, matte

6 WOOD BLOCKS
The two versions of the MEINL Wood Blocks are tonally matched.
MATERIAL Rubber Wood
(*Hevea brasiliensis* Muell.-Arg.)
FEATURE Rounded playing surface
INCLUDES Wooden beater
COLOUR **BK**: Black, matte

CASTANETS & KALIMBAS

 **FC1** **FC2**
TRADITIONAL CONCERT
JUAN CARLOS MELIAN, SPAIN

 **HC1**
TRADITIONAL

3  **KA5-S** **KA9-M** **KA7-M-BK**
EXTRA WIDE TONGUES FOR COMFORT



4  **KA9WW-BK**
WIDE OPENING FOR GREAT WAH-WAH EFFECTS

5  **KA9P-AB**
PICKUP SYSTEM WITH VOLUME CONTROL FROM *Shadow*

1 FINGER CASTANETS
Traditional Castanets are made in the style of southern Italian Tammurriata castanets.
SIZES **FC1**: Traditional
FC2: Concert
MATERIAL Rosewood (*Dalbergia sissoo*)
FEATURE Full and cutting resonance

2 TRADITIONAL HAND CASTANET
Traditional Hand Castanets are perfect for easy pick up and rapid, staccato play.
SIZE Traditional
MATERIAL Rosewood (*Dalbergia sissoo*)
FEATURES Balanced handle
Precisely formed contours for clear, distinct sound

3 SOLID KALIMBAS
The sound is pure joy, and a great addition to any percussion kit.
SIZES **KA5-S**: Small – g" c" f" f" c"
KA7-M-BK: Medium – e' g d" e c' a a'
KA9-M: Medium – a' c" c' a' A f' e" e" b'
MATERIALS Chrome plated steel
Rubber Wood
(*Hevea brasiliensis* Muell.-Arg.)
FEATURES Ergonomic shape
KA7-M-BK: Extra wide tongues for comfort

4 WAH-WAH KALIMBA
You can create a great wha-wha effect by simply bouncing the kalimba body on and off your belly as you play.

5 PICKUP KALIMBA
The internal pre-amp means you won't have to worry about playing up close to the mike. An external volume knob lets you easily adjust to any situation.
SIZE Medium – a' c' c' a' A f' e" e" b'
MATERIALS Chrome plated steel
Rubber Wood
(*Hevea brasiliensis* Muell.-Arg.)
FEATURES Pickup system with external volume control
Wah-wah effect
COLOUR **AB**: African Brown

HAND PERCUSSION



1 WOOD CLAVES, CLASSIC
 The MEINL Classic Wood Claves are the most common claves and produce the classic cutting sound.
MATERIALS **HW:** Hardwood
RW: Redwood
FEATURE Solid body

2 FIBERGLASS CLAVES
 Claves made from fiberglass produce the most penetrating, loud, and cutting sound of all.
MATERIAL Premium fiberglass
FEATURES Solid body
 Cutting sound
COLOUR **R:** Red

3 CLAVES DE LUXE
 Our Claves De Luxe are made from a superb, dense hardwood which delivers a cutting and bright tone.
SIZE 6 3/4" long
MATERIAL Dense hardwood
FEATURES Cutting sound
 Convenient carrying

4 PROFESSIONAL SALSA CLAVES
 The MEINL Professional Salsa Claves are made out of a high density wood that allows these instruments to have a loud sound that will cut through the ensemble in live situations. They have a high pitch and are very durable.
MATERIAL African Blackwood
FEATURES Solid body
 Cutting sound

5 WOOD CLAVES, AFRICAN
 African Claves are slightly larger and have a lower fundamental pitch. Additionally, the resonating body is larger than the striker. Available in two different versions: Solid and hollowed out body.
MATERIALS **HW:** Hardwood
RW: Redwood
FEATURES **CL2:** Solid body
CL3: Hollowed out body



1 BIRDS/WATERFALL
 The MEINL Birds and Waterfall realistically imitate the sound of a flock of birds or a rippling waterfall. Fiberglass and wooden versions available.
MATERIALS **BI7RY, WA7BK:** Premium fiberglass
BI1NT, WA1NT, BI2NT, WA2NT: Rubber Wood
 (Hevea brasiliensis Muell.-Arg.)
COLOURS **NT:** Natural
BK: Black
RY: Red/Yellow

2 FOOT RATTLE
 The Foot Rattle goes with everything. Marks pulse with moderate volume and warmth.
MATERIAL Rubber Wood
 (Hevea brasiliensis Muell.-Arg.)
FEATURE Hook and loop fastener
COLOUR **NT:** Natural

3 THE NIGHT
 When playing The Night, four solid steel balls hit a cylindrical metal rod in quick succession producing the unique sound of crickets.
MATERIALS Solid steel balls and cylinder
 Wooden body
FEATURE Ergonomically shaped handle
COLOUR **AM:** Amber

4 KOKIRIKOS
 The Kokiriko originated in Japan as a sound effect instrument. It produces a rattling effect which can be an almost silent rustling to an extremely loud catter.
MATERIAL Wood
FEATURES **KO1AM:** Ergonomically shaped handle
 Durable cord
KO2AM/BK: Ergonomically designed handgrips
 Wide, stable binding strap in real leather
COLOURS **AM:** Amber
AM/BK: Amber/Black

5 THE ROAR
 A rattling effect is achieved by striking the ball end against the palm of the hand.
MATERIALS Wood
FEATURE Rattling sustain

1



Spark shaker
SH16

CIRCULAR MOTION
ENABLES A UNIQUE
RATTLING

2



Spin spark
SH17

SCREW-MOUNTED DISC
ENABLES A TUNABLE
PITCH



3



Clamshell spark, set of two
SH22

HIGH PITCH & LOW PITCH

4



Headed spark
SH18

SENSATIONAL EFFECTS ARE PRODUCED WHEN
COMBINED WITH ANOTHER SPARK SHAKER



INVENTOR: BILL SARAGOSA

1 ORIGINAL SPARK SHAKER

The sparkling, chirping, splashing tones readily mix with almost any musical flavour. The pod-like shape fits easily into the hand and may be manipulated for many interesting effects. Spark Shakers may be played in pairs, or in combination with other shakers for even more variations.

SIZE Medium
MATERIALS Shaker: Coated steel
Pellets: Coated steel
FINISH Black nickel

2 SPIN SPARK SHAKER

The MEINL Spin Spark Shaker is equipped with a screw-mounted disc that adjusts and amplifies the characteristics of the fundamental pitch. When the disc is tight, the pitch is highest; and it deepens as

the disc is loosened. There is a distinctively pleasant supplemental timbre.

SIZE Medium
MATERIALS Shaker: Coated steel
Pellets: Coated steel
FINISH Black nickel

3 CLAMSHELL SPARK SHAKERS

Clamshell Spark Shakers have a single solid weld holding the two halves of the shell together like a hinge. When you squeeze the two halves together, you get a wildly variable pitch response. It comes in two pitches, for high-low combinations.

MATERIAL Steel
FEATURES Comes in a set of two
Wildly variable pitch response
FINISH Black nickel

4 HEADED SPARK SHAKER

One side of the MEINL Heated Spark Shaker is a drum head! Premium goatskin and a steel shell provide a rattling combination of crisp warm tones and a bright metal timbre.

SIZE Medium
MATERIALS Shaker: Coated steel
Pellets: Coated steel
Goat head
FEATURES Swirling effect
Variable pitch
FINISH Black nickel

1



LUIS CONTE, USA

SOFT STUDIO

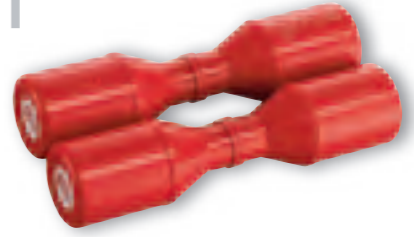

Studio shaker, red
SH5R

72 - 76 DB

MED LIVE



Live shaker, black
SH4BK

79 - 81 DB

LOUD STADIUM



Stadium shaker, grey
SH45GR

88 - 93 DB

2



Large
SH12-L-BK



Medium
SH12-M-BK



JUNIOR MORAES, BRAZIL

1 ARTIST SERIES SHAKERS (LUIS CONTE)

The three versions have been designed according to master percussionist Luis Conte's exact requirements. "My shaker sound is as smooth as silk" is how Luis described their sound.

SIZE Medium
MATERIAL Plastic
FEATURE Two individual shakers connected as one instrument
COLOURS **SH4BK** (Live Shaker): **BK**: Black
SH45GR (Stadium Shaker): **GR**: Grey
SH5R (Studio Shaker): **R**: Red

2 STUDIOMIX SHAKERS

The StudioMix Shakers have a crisp full sound and come in two sizes. The textured surface both enhances the timbre and enables a positive grip. Lightweight plastic body is virtually unbreakable.

SIZES Medium
Large
MATERIAL Plastic
FEATURE Textured surface for special sound and positive grip
COLOUR **BK**: Black



Small
SH8BK

AMEL SERRA,
NETHERLANDS



Medium
SH88BK



Large
SH888BK



Large
SH10-L-BK

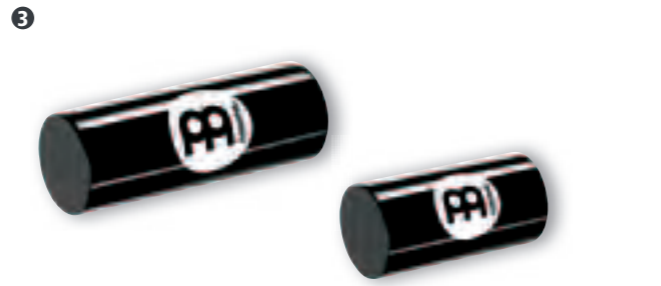

Large
SH7-L-BK

Medium
SH7-M-BK



Medium
JS88BK

INVENTOR:
JUAN CARLOS MELIAN

BY TILTING THE SHAKER 90° TO
THE FRONT THE JINGLES START
TO CLICK ON THE BEAT



Large
SH15-L

Medium
SH15-M

Small
SH15-S

BLACK MAKAH-BURL



Small
SH6-S-BK

TWO DIFFERENT MATERI-
ALS PRODUCE EXPERIMEN-
TAL SOUNDS



Medium
SH20BK

BY COVERING AND
UNCOVERING THE SOUND
HOLE, A "WAH-WAH"
EFFECT CAN BE ACHIEVED



Medium
SH3BK

LOUD AND PENETRATING
SOUND DUE TO THE
MANY HOLES



Large
SH9-L-S



Medium, black
SH21BK

Medium, grey
SH21GR

1 ALUMINUM SHAKERS, OCTAGONAL

MEINL's Octagonal Aluminum Shakers come in three different sizes. All have a broad dynamic range with lots of volume.

SIZES **SH8BK**: Small
SH88BK: Medium
SH888BK: Large

MATERIAL Aluminum
COLOUR **BK**: Black

2 STUDIO SHAKER

MEINL's Studio Shaker was designed to meet all the requirements necessary in today's session world. It delivers a very tasteful and delicate shaker sound with a warm tone and a well balanced frequency spectrum.

SIZE Large
MATERIAL Plastic
COLOUR **BK**: Black

3 FIBERGLASS SHAKERS

These MEINL Shakers are made from premium fiberglass for more durability and better sound quality. They are light weight and very comfortable to play.

SIZES **SH7-M-BK**: Medium
SH7-L-BK: Large

MATERIAL Premium fiberglass
COLOUR **BK**: Black

4 ALUMINUM JINGLE SHAKER

The MEINL Aluminum Jingle Shaker (designed by Juan Carlos Melian) has two pairs of steel jingles which are attached in one row to an octagonal aluminum shaker.

SIZE Medium
MATERIALS Shaker: Aluminum
Jingles: Steel
COLOUR **BK**: Black

5 WOOD SHAKERS

Made from a combination of selected woods, these new MEINL Wood Shakers offer a nice array of alternative sounds.

SIZES **SH15-S**: Small
SH15-M: Medium
SH15-L: Large

MATERIALS Rubber Wood
(*Hevea brasiliensis* Muell.-Arg.)
Top and Bottom: Black Makah-Burl

6 RAWHIDE SHAKER

The MEINL Rawhide Shaker combines two different materials into one unique instrument. It produces very experimental sounds and works perfectly in modern music productions.

SIZE Small
MATERIALS Plastic with natural rawhide side caps
COLOUR **BK**: Black

7 WAKAH SHAKER

The shaker has two chambers which are separated by a plastic membrane. By covering and uncovering the sound hole, a "wah-wah" effect can be achieved

SIZE Medium
MATERIALS Wooden body and plastic chamber
COLOUR **BK**: Black

8 LOOP SHAKER (US PATENT)

The MEINL Loop Shaker has a crackling bright sound with many dynamics, and is easy to control. It is very responsive to hand pressure and movement, giving it a soft or loud voice as needed.

SIZE Medium
MATERIAL Plastic
FEATURE Loud and penetrating sound due to the many holes (US patent)
COLOUR **BK**: Black

9 ALUMINUM SHAKERS, ROUND

The MEINL Round Aluminum Shakers were designed to cut through loud live music.

SIZE Large
MATERIAL Anodized aluminum
COLOUR **S**: Silver

10 U.F.O. SHAKERS

The black MEINL U.F.O. Shaker produces an extreme mellow and smooth sound and less attack, while the grey version has a crisper sound with more volume.

SIZE Medium
MATERIAL Plastic
COLOURS **BK**: Black
GR: Grey



1 RAWHIDE MARACAS
Rawhide Maracas are entirely made by hand and are offered in three different sizes for a wide sonic range.
SIZES **MSM2:** Mini
MSM3: Traditional
MSM4: Jumbo
MATERIALS Natural rawhide and wooden handle

2 STUDIO, CONCERT, LIVE MARACAS
This lightweight plastic maracas provide stability and a strong, projecting sound.
MATERIAL Plastic
FEATURE Ergonomically shaped handle
COLOUR **BK:** Black

3 PLASTIC EGG MARACAS
Made from special plastic material, the MEINL Egg Maracas have a clear and crisp tone with a comfortable handle for absolute control.
SIZE 6"
MATERIAL Plastic
FEATURE Ergonomically shaped handle

4 WOOD MARACAS
The traditional MEINL Wood Maracas are available in both round and oval models. Both of these exhibit a traditional warm and rich sound.
MATERIAL Wood

5 MARACLAVES
The MEINL Maraclaves are an exciting hybrid percussion instrument. They are a pairing of full volume maraca "bulbs" mounted on solid American White Ash "handles". The result is a new way to combine the two timbres inside an efficient set of movements. MEINL Maraclaves offer new possibilities in sounds, rhythms, and showmanship!
MATERIALS American Ash wood (*Fraxinus americana* L.)
Plastic shaker head
FEATURES Can be played like maracas and claves at the same time
Precise and cutting sounds
Durable construction
Detailed with logo heat-branded on handle
COLOUR **BG:** Beige

NEW POSSIBILITIES IN SOUNDS, RHYTHMS, AND SHOWMANSHIP
INVENTOR: DANY MORENO

HAND PERCUSSION



1 EGG SHAKER SET
Set of four Shaker Eggs fit all your needs in the studio or on the road.
MATERIAL Plastic
FEATURE Range of volume from soft to extra loud

2 PLASTIC EGG SHAKERS
MATERIAL Plastic
COLOURS **B:** Blue, **BK:** Black, **GREEN:** Green
R: Red, **Y:** Yellow
FEATURE Comes in a set of two

3 WOOD EGG SHAKER
SIZE Jumbo
MATERIAL Wood
COLOUR **BK:** Black



4 EGG SHAKER BOX
FEATURE Holds 60 egg shakers

5 DOUBLE SHAKER/GANZA
MATERIALS Rattan with coconut bottom

6 CAXIXIS
MATERIALS Rattan with coconut bottom

7 WOODEN FROGS
SIZES Medium, Large

8 PLASTIC GÜIRO
MATERIAL High strength plastic
FEATURE Three striking surfaces rubber ringed grip holes
INCLUDES Plastic Scraper
COLOUR **BK:** Black



9 FIBERGLASS GÜIRO
MATERIAL Premium fiberglass
FEATURES Three striking surfaces
Padded grip holes
INCLUDES Plastic scraper
COLOUR **BK:** Black

10 WOOD GÜIROS
MATERIAL Wood
FEATURES **GU1AM:** Grip holes
GU2AB-M: Three striking surfaces Grip holes
INCLUDES **GU1AM:** Wooden scraper
GU2AB-M: Plastic scraper
COLOURS **AB-M:** African Brown, matte
AM: Amber

HAND PERCUSSION

THREE PLAYING SURFACES



RAINMAKER & RAINSTICKS



RA7BK

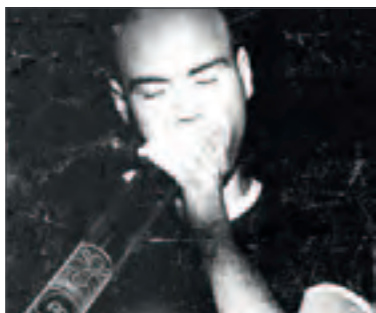

HOW WE MAKE IT

01 The synthetic didgeridoos are being prepared for hand painting. The black base colour is applied first.

02 Every MEINL Didgeridoo/Rainstick is a hand-painted unique piece of art.

03 You can see how much care and detail goes into each didgeridoo.



39" RS1BK-L
24" RS1R-M
16" RS1BK-S



39" SRS1R-L

1 RAINMAKER

The MEINL Rainmaker is uniquely different. Due to the circular construction, it can be mounted on a cymbal stand and by simply turning the instrument a drizzle can immediately change into the sound of a monsoon.

MATERIAL Premium fiberglass
FEATURE Circular construction
INCLUDES Ergonomically shaped handle
COLOUR BK: Black

2 WOOD RAINSTICKS

Natural Bamboo makes our Rainsticks pleasant effect instruments, with plenty of projection and long sustain. They may be played like big shakers as well.

SIZES 16" (40 cm)
24" (60 cm)
39" (100 cm)

MATERIAL Bamboo
COLOURS BK: Black
R: Red

3 SYNTHETIC RAINSTICK

The MEINL Synthetic Rainstick is light in weight and extremely durable.

SIZE 39" (100 cm)

MATERIAL Lightweight synthetic
COLOUR R: Red



DIDGERIDOOS



NEW!



47" DDG1-BK
47" DDG1-BR
47" DDG1-R
51" SDDG1-BK
51" SDDG1-R

1 WOOD DIDGERIDOOS

These Didgeridoos are a great way to get started on the oldest wind instrument in the world. It makes a distinctive drone with harmonic overtones, and goes great with all kinds of percussion. These didgeridoos are made from Bamboo.

SIZE 47" long (120 cm)
MATERIAL Bamboo
COLOURS BK: Black
BR: Brown
R: Red

2 SYNTHETIC DIDGERIDOOS

The MEINL Synthetic Didgeridoos are a modern twist on the traditional bamboo construction. They are extremely durable and are unaffected by weather so they are perfect for outdoor use.

SIZE 51" (130 cm)
MATERIAL Lightweight synthetic
COLOURS BK: Black
R: Red

NEW!



8 1/2" x 5"
DDG-BOX



SMALL IN SIZE BUT BIG IN SOUND

3 TRAVEL DIDGERIDOO (US PATENT)

The new MEINL Travel Didgeridoo is small in size but big in sound. The zigzag design on the inside enables authentic didgeridoo sounds. Its compact size makes it the perfect instrument to take on the road or to the studio without taking too much space.

SIZE 8 1/2" x 5"
MATERIAL Mahogany Wood
FEATURE Hot-branded logo
Compact design

INVENTOR: MARK ALLEN JOHNSON

DIDGERIDOOS



36"–62"
TSDDG1-BK

TWO TELESCOPING SECTIONS



57" **PROFDDG1-BK** 57" **PROFDDG2-BR**

ABOUT SIMON "SI" MULLUMBY

Si has developed a totally new style of playing didgeridoo. Mixing tight vocal percussive beats with deep bass grooves an awesomely textured sonic environment is created.

Within the 20 years he has been playing he has become one of the most respected didgeridoo players in the world. Si has a strong following in Australia, Japan and Europe after touring many times with his dance band Wild Marmalade. In 2004 Si became the first didgeridoo player in history to have had a contract with the world famous "Cirque du Soleil" in Las Vegas.

Si was inspired to play after a mystical experience in India where he realized that it was his life purpose to play didgeridoo. After this experience he left medical school and hitchhiked around Australia. Playing intuitively for many years Si went on to study drumming and body percussion then entering the professional arena as a didgeridoo musician.



ARTIST SERIES DIDGERIDOO

SIMON "SI" MULLUMBY, AUSTRALIA



61"
SDDG1-SI

1 TROMBONE DIDGERIDOO

The MEINL Trombone Dideridoo can vary in pitch like a slide trombone. One section has the mouthpiece and slides into the bell section. Pitch intervals are painted clearly on the side of the instrument. Hand finished with exotic Australian style dot painting.

- SIZE** 36"–62"
- MATERIAL** Premium fiberglass
- FEATURES** Two telescoping sections for variable pitch
Tuning from: G# G F# F E D# D C# C
- COLOUR** **BK:** Black

2 FIBERGLASS DIDGERIDOOS

Our Professional Didgeridoos are made from premium fiberglass for unsurpassed stability and long life. A flared bell enhances the sound projection, and the hand-painted designs make them truly beautiful.

- SIZE** 57" long (145 cm)
- MATERIAL** Premium fiberglass
- COLOURS** **BK:** Black
BR: Brown

ARTIST SERIES DIDGERIDOO (SIMON "SI" MULLUMBY)

"Resonant, easy to play, and good for players of all levels my Artist Series Didgeridoo has unique design features giving it incredible playability. Designed for speed playing and warmth of tone this instrument is a guaranteed win for those looking for a quality didgeridoo" comments Simon "Si" Mullumby.

- SIZE** 61" long (154 cm)
- MATERIAL** Premium fiberglass
- COLOUR** Grey



1



16" CA16C 14" CA14C

2



10" CA10S

HAND HAMMERED

3



10" CA10PH

QUICK RESPONSE WHEN HIT BY A HAND



YOGI JOKUSCH, GERMANY

4



18" CA18CR

5



14" CA14PJB

BUILT-IN JINGLES

1 PERCUSSION CRASHES

The crashes are thin, tonally matched cymbals which can be played by hand or hit with a stick. They respond fast and decay quickly.

- SIZES 14", 16"
- MATERIAL B20 Bronze
- FEATURES Hand-hammered
Brilliant finish
Fast response and attack
Quick decay

2 PERCUSSION SPLASH

The percussion splash is an extremely thin, quick sounding cymbal – perfect for fast percussive accents.

- SIZE 10"
- MATERIAL B20 Bronze
- FEATURES Hand-hammered
Brilliant finish
Fast response and attack
Quick decay

3 PERCUSSION HIHAT

A specially designed hi-hat just for cajon players. It can be played by hand or with lighter sticks. The top is extremely thin for a fast, controlled response. Recommended for use with the MEINL Low Hat.

- SIZE 10"
- MATERIAL B20 Bronze
- FEATURES Can be played by hand or with lighter sticks
Recommended for use with the MEINL Low Hat

4 TIMBALES CRASH/RIDE

It's the perfect cymbal for timbale playing. It has a loud, penetrating bell and a full, warm crash sound.

- SIZE 18"
- MATERIAL B20 Bronze
- FEATURES Hand-hammered
Brilliant finish
Cutting bell sound
Great crash sound

5 PERCUSSION JINGLE BELL

A great cymbal with an exotic sound. Six pairs of jingles attached to this cymbal produce a rattling effect.

- SIZE 14"
- MATERIAL B8 Bronze
- FEATURES Precisely hammered
Built in jingles





STICKS & BEATERS & SCRAPERS

1



Black **TBRS-BK**
Red **TBRS-R**

2



FDT5



INVENTOR OF FDT5:
THÓRRALF SCHUH

3



5/16" x 15" **TS5/16**
3/8" x 15" **TS3/8**
7/16" x 16" **TS7/16**
1/2" x 16" **TS1/2**



FDT4

FDT2

FDT3

FDT1

4



Long **SST1-L**
Medium **SST1-R**
Short **SST1-S**

Sevenfold **SST7**
Sixfold **SST6**
Triple **SST3**
Triple short **SST3-S**

1 TAMBORIM STICKS

The MEINL Tamborim Sticks have three balanced, flexible plastic rods in a handy size.

MATERIAL Plastic
COLOURS **BK**: Black
R: Red

2 BODHRAN TIPPERS

The MEINL Bodhran Tippers come in five different styles, each with its own characteristic. They range from thin and light, to thick and full bodied. A special tipper with leather whips was designed by Thórralf Schuh.

MATERIAL Ash Wood
COLOUR African Brown

3 TIMBALE STICKS

The MEINL Timbale Sticks are made out of the finest hand-selected Hickory Wood and are available in four different sizes.

MATERIAL Hickory Wood
SIZES **TS5/16**: 5/16" x 15",
TS3/8: 3/8" x 15",
TS7/16: 7/16" x 16",
TS1/2: 1/2" x 16"

4 SAMBA STICKS

MEINL offers a wide assortment of Samba Sticks for Tamborims, Repiniques, and other Samba instruments in order to achieve their authentic sounds.

MATERIAL Plastic
SIZES **SST1-S**: Stick, short version
SST1-R: Stick, medium version
SST1-L: Stick, long version
SST3-S: Triple stick, short version
SST3: Triple stick
SST6: Sixfold stick
SST7: Sevenfold stick

5



2" felt beater **SB1**

2" felt beater **SB2**

2 1/2" felt beater **SB3**

2" leather beater **SB4**

Wood beater **SB6**

3" bushy felt beater **SB5**

Two 2" felt beater **SB2-D**

Two 2 1/2" felt beater **SB3-D**

6



SBH

7



Rattan **SPARE-10**

Mahogany Wood **SPARE-23**

8



COW1 **COW2** **COW1BK**



RIBBED GRIP

9



Wood **MGS1**

ABS **MGS2**

5 SAMBA BEATERS

MEINL offers a wide assortment of Samba Beaters for Surdos and Repiniques in order to achieve their authentic sounds. All beaters are made from high quality materials to assure comfortable playing.

SB1: 15" long, aluminum stick with 2" felt beater
SB2: 16" long, wood stick with 2" felt beater
SB2-D: 16" long, wood stick with two 2" felt beater
SB3: 16" long, wood stick with 2 1/2" felt beater
SB3-D: 16" long, wood stick with two 2 1/2" felt beater
SB4: 16" long, wood stick with 2" leather beater
SB5: 16" long, wood stick with 3" bushy felt beater
SB6: 16" long, wood stick

6 SURDO BEATER HOLDER

Keep your Surdo Beaters at the ready, comfortably hanging on your belt.

MATERIAL Leather
COLOUR Black

7 TALKING DRUM BEATERS

The curved playing end of the Talking Drum Beaters enables ideal positioning to strike the drum head, held near the player's body.

SPARE-10: Rattan
SPARE-23: Mahogany Wood

8 COWBELL BEATERS

MEINL offers a regular and professional cowbell beater for more sound options.

MATERIAL Rubber Wood
(*Hevea brasiliensis* Muell.-Arg.)
FEATURES Ribbed grip
Padded beater section

9 GÜIRA SCRAPERS

MEINL offers a wooden and an ABS Güira Scraper for more sound options and different playing techniques.

MATERIALS **MGS1**: Ergonomic wooden grip
MGS2: Sanded ABS grip
Steel rods

1



Black powder coated
For Marathon® Classic/Designer Series
For Luis Conte Artist Series
ST-MCC11BK: 11"
ST-MCC1134BK: 11 3/4"
ST-MCC1212BK: 12 1/2"

Chrome plated
For Floatune Series
ST-FL10CH: 10"
ST-FL11CH: 11"
ST-FL12CH: 12"
ST-FL13CH: 13"
For Professional Series
For Fibercraft Series
ST-MP11CH: 11"
ST-MP1134CH: 11 3/4"
ST-MP1212CH: 12 1/2"

Chrome plated
For Woodcraft Series
ST-WC11CH: 11"
ST-WC1134CH: 11 3/4"
ST-WC1212CH: 12 1/2"

Gold tone
For Mongo Santamaria Artist Series
ST-MSA11G: 11"
ST-MSA1134G: 11 3/4"
ST-MSA1212G: 12 1/2"



Black powder coated Chrome plated Gold tone

QUICK AND EASY
HEIGHT ADJUSTABILITY
(DE PATENT)

2

Black powder coated
ST-HEBK

Chrome plated
ST-HECH

Gold tone
ST-HEG



EASY AND EFFECTIVE
HEIGHT EXTENSION

3

NEW!

NEW!



For Headliner®
congas
HDSTAND



For MCC congas
TMDs

4



Chrome plated
TMC-CH

COMPATIBLE
FOR ALL SIZES!

THE LIGHTWEIGHT STAND CAN
BE FOLDED TO A COMPACT UNIT
WHICH REQUIRES LITTLE SPACE

1



Black powder coated
THBS-BK



Chrome plated
THBS



AN INNOVATIVE DESIGNED BRACKET
ENABLES QUICK SET UP (PATENTED)

2



Chrome plated
TMB

PADDLED T-SHAPED TUBE FOR MORE STABILITY

3



Chrome plated
TMB-S

A STABLE METAL CLAMP HOLDS
THE ENTIRE UNIT IN PLACE

LOW HEIGHT FOR
SEATED PLAYERS

1 STEELY II CONGA STANDS (PATENTED)

The MEINL Steely II Conga Stands are available for all MEINL Professional Series Congas.

MATERIAL Steel
FEATURES Metal spike attachment on each leg
L-shaped legs (DE, TH, US patent)
U-shaped notch for quick set up and break-down (US patent)
Ergonomic arched rubber bracing for more stability (CN, DE, US patent)
Notches for quick height adjustability (DE patent)

INCLUDES Allen wrench

which provides a more comfortable playing position for taller congueros.

MATERIAL Steel
FEATURES Easy and effective height extension
INCLUDES Mounting screws
Allen wrench
FINISHES Black powder coated
Chrome plated
Gold tone

3 CONGA DOUBLE STANDS

Specially designed to hold two congas at once. It is fully height adjustable and features a memory lock for a quick set up.

MATERIAL Steel
FEATURES Height adjustable
Double braced tripod legs

INCLUDES Allen wrench
Memory locks
Brackets
Set of screws, nuts, and washers
Mounting description

4 PROFESSIONAL CONGA STAND

The Professional Conga Stand is unique with respect to design and function. It was especially developed to accommodate the rigors of professional road use, where fine adjustment and durability are demanded.

MATERIAL Chrome plated steel
FEATURES Unique design (DE, US patent)
Rubber padded crossbeams
Fully height adjustable
Folds up to a compact unit

INCLUDES Allen wrench
Memory locks

1 HEADLINER® SERIES BONGO STANDS (CN, DE, US PATENT)

These bongo stands combine easy handling and functionality with reliability and sturdy construction. A newly designed bracket enables extremely quick and easy mounting, yet holds the entire bongo securely in place.

MATERIAL Steel
FEATURES Quick set up
Easy handling
Reliable placement
Double braced tripod stand
Fits all common bongos

INCLUDES Wrench
COLOURS **THBS:** Chrome
THBS-BK: Black

2 PROFESSIONAL BONGO STAND

The MEINL Bongo Stand features a new design concept and simple functionality. The bongo is placed on a padded T-shaped tube and secured with a convenient knob screw. A stable metal clamp holds the entire unit securely in place.

MATERIAL Chrome plated steel
FEATURES Padded T-shaped tube
Fully height- and angle adjustable
Double braced tripod legs
Fits all common bongos

INCLUDES Allen wrench
Memory locks

3 PROFESSIONAL BONGO STAND FOR SEATED PLAYERS

This version of MEINL's Professional Bongo Stand has all the features of the regular model. However, it can be placed low enough to be comfortably played sitting down in the traditional position.

MATERIAL Chrome plated steel
FEATURES Seated playing position possible
Padded T-shaped tube
Fully height- and angle adjustable
Double braced tripod legs
Fits all common bongos

INCLUDES Allen wrench
Memory lock

1

NEW!



Black powder coated
STDJST-BK

COLLAPSIBLE DESIGN

2



Chrome plated
ST-DJEMBE



ADJUSTABLE TO ACCOM-
MODATE VARIOUS DJEMBE
SIZES USING THREE SPACERS

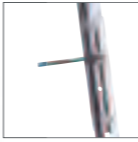

QUICK AND EASY
HEIGHT ADJUSTABILITY
(DE PATENT)

3



Chrome plated
TMD



LENGTH ADJUSTABLE FOR
VARIOUS DJEMBE SIZES

4



Black powder coated
TMCAJ

NEW!

FITS FOR ALL CAJON SIZES

5



Chrome plated
TMTS

THREE-ARM BASKET HOLDS
THE HAND-BALE SECURELY

6



Chrome plated
MLH

SPECIAL LOW HEIGHT



7



Chrome plated
TMCH

SPECIALLY DESIGNED TO HOLD
CHIMES, NOT CYMBALS

8



Chrome plated
TMID



FOAM PADDED RING

9



Chrome plated
TMPS



DIFFERENT RODS
FOR ALL NEEDS

1 TRAVEL DJEMBE STAND

The practical design makes it perfect for drum circles.

MATERIAL Black powder coated steel

FEATURES Collapsible design
Lightweight construction

2 STEELY II DJEMBE STAND (PATENTED)

It can be adjusted to accommodate various djembe sizes and is fully height adjustable.

MATERIAL Chrome plated steel

FEATURES Metal spike attached to each leg
L-shaped legs (DE, TH, US patent)
U-shaped notch for quick set up and break-down (US patent)
Ergonomic arched rubber bracing for more stability (CN, DE, US patent)

Notches for quick height adjustability (DE patent)
Adapts to different djembe sizes

INCLUDES Allen wrench, 3 spacers

3 PROFESSIONAL DJEMBE STAND

The MEINL Djembe Stand was designed to firmly hold any djembe in the traditional playing position.

MATERIAL Chrome plated steel

FEATURES Rubber padded hooks
Fully height- and angle adjustable
Double braced tripod legs

INCLUDES Allen wrench
Memory lock

4 PROFESSIONAL CAJON STAND

The MEINL Cajon Stand is fully adjustable and fits for all common cajon sizes.

MATERIAL Steel

FEATURES Quick set up
Fully height- and angle adjustable
Double braced tripod stand
Fits for all cajon sizes

5 HAND-BALE STAND

Our Hand-Bale Stand is double-bracketed and fully adjustable.

MATERIAL Chrome plated steel

FEATURES Quick set up
Rubber-tipped three arm basket
Easy handling
Double braced tripod stand

6 LOW HAT

The Meinl Low Hat has been designed with a special low height, made just for cajon players.

MATERIAL Chrome plated steel

FEATURES Special low height
Made just for cajon players

7 CHIMES STAND

Our Chimes Stand is a fully-adjustable, double braced tripod stand, specially designed for mounting bar chimes just the way you want them to be held! Made from sturdy chrome-plated steel for dependability. Special padding eliminates unwanted movement, and rubber feet prevent slipping.

MATERIAL Chrome plated steel

FEATURES Full angle and height adjustability
Secure angle clamps
Telescoping stem

8 PROFESSIONAL DOUMBЕК/IBO STAND

This Stand was designed to enable playing an Ibo Drum or a Doumbek in ways other than simply being placed in one's lap, such as standing up or incorporating it into a percussion set up. It can be angled and is fully height adjustable.

MATERIAL Chrome plated steel

FEATURES Foam padded ring
Fully height- and angle adjustable
Double braced tripod legs

INCLUDES Allen wrench
Memory lock

9 PERCUSSION STAND

The MEINL Percussion Stand is a universal device which offers a variety of set up solutions for both drummers and percussionists. It is fully height adjustable and features both quick locks and memory locks for a quick set up.

MATERIAL Chrome plated steel

FEATURES Height adjustable
Double braced tripod legs

INCLUDES Allen wrench
Memory locks
2 straight rods
2 angled rods
2 Z-shaped rods

1 NEW!



20" x 12 1/2"
TMLTS



CORD STRAIN RELIEF



FIVE STOPPERS AND HOOK AND LOOP FASTENER TO SECURE THE LAPTOP



REMOVABLE HOLDER FOR HEADPHONES

1 LAPTOP TABLE STAND

The MEINL Laptop Table Stand comes with a strap and stoppers that secure the computer to it. The perforated metal plate ensures that the laptop gets always good ventilation.

- SIZE** 20" x 12 1/2"
- MATERIAL** Perforated metal plate
- FEATURES** Holds laptops up to 17"
Stoppers and hook and loop fastener to secure the laptop
Holder for headphones
Cord strain relief

2 PERCUSSION TABLES

These Percussion Tables are made from durable fiberglass and offer enough room for all common hand percussion instruments.

- SIZES** **MC-PT:** 18" x 12"
MC-PT-JB: 18" x 12"
MC-PTS: 12" x 12"
- MATERIAL** Premium fiberglass
- FEATURES** Fabric anti-slip surface
Adjustable angle
Strong mounting clamp
MC-PT-JB: Jawbreaker motif



CRISTIAN LA TORRE, CHILE

2



12" x 12" **MC-PTS** 18" x 12" **MC-PT** 18" x 12" **MC-PT-JB**



FABRIC ANTI-SLIP SURFACE

NEW!

4



ALL MEINL TRIPOD STANDS ARE EQUIPPED WITH MEMORY- AND QUICK LOCKS



16" x 22"
TMPTS

3 PERCUSSION WORKSTATION

Made with great attention to detail, the MEINL Percussion Workstation has been designed to be customized according to the player's demand.

- MATERIAL** Black powder coated steel
- FEATURES** Fully height adjustable
Angle adjustable top bar
Fabric anti-slip surface
Heavy duty construction
Infinitely expandable
Fabric anti-slip surfaces
Colour doesn't interfere with stage lighting
- INCLUDES** 1 pc 22" x 24" padded fiberglass percussion table
2 pcs 18" x 12" padded fiberglass percussion tables (attachable)

- 1 pc 30" vertical bar
- 2 pcs 15" vertical bars (attachable)
- 4 pcs straight rods with hook
- 3 pcs angled rods with hook
- 1 pc Z-shaped rod with hook

4 PERCUSSION TABLE STAND

Our Percussion Table Stand offers enough room for all common hand percussion instruments. It is fully height adjustable and has a fabric anti-slip surface.

- SIZE** 16" x 22"
- MATERIALS** Table: Premium fiberglass
Stand: Chrome plated steel
- FEATURES** Fabric anti-slip surface
Fully height adjustable
Double braced tripod legs
- INCLUDES** Allen wrench
Memory lock

3



Black powder coated
TMPWS



HEIGHT ADJUSTABILITY AT ALL POINTS

5



INVENTOR:
TAKU HIRANO, USA



ERGONOMIC SHAPE FOR MORE EFFICIENCY



20" x 34"
TMPETS

5 ERGO TABLE

The curved shape helps you to fit it into your set-up with no space wasted, while keeping everything within easy reach. The inner raised edge is padded, so that instruments may be picked up and set down with an absolute minimum of contact noise.

- SIZE** 20" x 34"
- MATERIALS** Table: Premium fiberglass
Stand: Chrome plated steel
- FEATURES** Fabric anti-slip surface
Padded edge
Fully height adjustable
Ergonomic shape for more efficiency
Double braced tripod legs
- INCLUDES** Allen wrench
Memory lock

1



Frame Drum Holder
MC-FDH

FULLY ADJUSTABLE FOR ANY FRAME DRUM SIZE

2



Tambourine Holder
MC-TH

PADDED SURFACE AGAINST RATTLING

3



Wood Block Holder
MWBH1

4

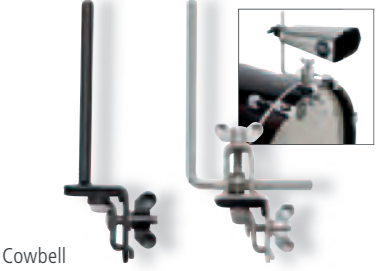

Cowbell Bass Drum Holders
MC-STBD **MC-BD**

5

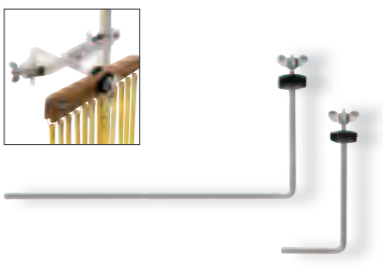

Chimes Holders
MC-CHL **MC-CH**

6



Triangle Holder
MC-TRI

7



Shaker Holder
MC-SH

8



Güiro Holder
MC-GU

9



Cabasa Holder
MC-CA

10



Ibo Holder
TMIH

ENABLES TO PLAY THE IBO WITH BOTH HANDS ON A TABLE

11



Drumstick Holder
MEINL
MC-DSH

11



Drumstick Holder
Jawbreaker
MC-DSH-JB

12

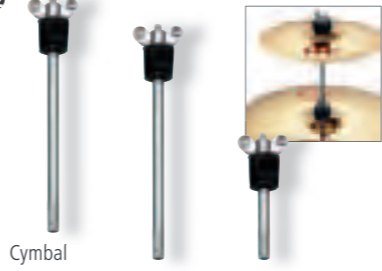

Cymbal Stackers
MC-CYS **MC-CYS8** **MC-CYS8-S**

13



Cymbal Holder
MC-CY

14



Cymbal Attachment
MCA

15



Multi Clamp, one mount
MC-1

16



Multi Clamp, two mounts
MC-2

17

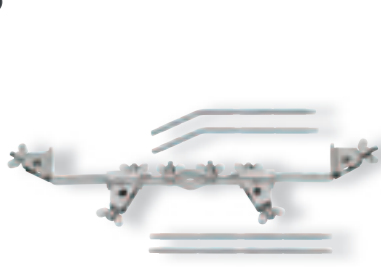

Multi Clamp, four mounts
MC-4

18

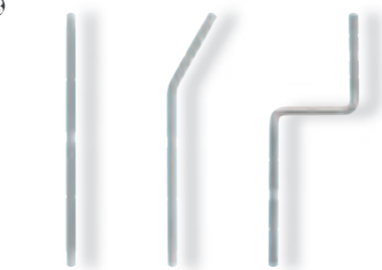

Straight rod **MC-R1** Angled rod **MC-R2** Z-shaped rod **MC-R3**

19



Clamp
CLAMP

20



Pedal Mount
PM-1

FITS ON ALL COMMON BASS DRUM PEDALS AND FIRMLY HOLDS COWBELLS, BLOCKS, OR TAMBOURINES

21

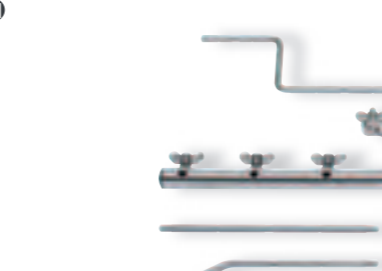

Mounting Bar
PMC-6

21

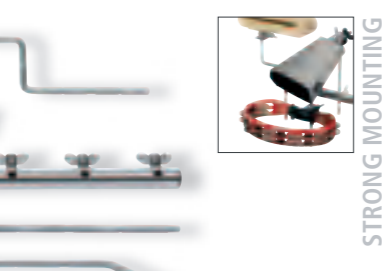

STRONG MOUNTING CLAMP

HOLDERS
MEINL offers a wide range of holders and other hardware for several instruments or needs. Smart designed and practical in use.
MATERIAL Chrome plated steel (if not differently indicated)

1 FRAME DRUM HOLDER
MATERIALS Anodized aluminum
Chrome plated steel
FEATURE Fully adjustable

2 TAMBOURINE HOLDER
FEATURES Rubber pads against scratching
Padded surface against rattling

3 WOOD BLOCK HOLDER

4 COWBELL BASS DRUM HOLDERS
MATERIALS **MC-BD:** Chrome plated steel
MC-STBD: Black powder coated steel
FEATURES Fully adjustable
Rubber pads against scratching
INCLUDES L-shaped rod

5 CHIMES HOLDERS
SIZES Regular
Large
FEATURES Knurled surface
Foam washer

6 TRIANGLE HOLDER
FEATURES Knurled surface
Nylon cord

7 SHAKER HOLDER
FEATURES Rubber pads against scratching
Length adjustable
Strong mounting clamp

8 GUIRO HOLDER
FEATURE Rubber pads against scratching

9 CABASA HOLDER
FEATURES Strong mounting clamp
Padded surface

10 IBO HOLDER
MATERIAL Black powder coated steel
FEATURES Allen wrench
Foam padded base

11 DRUMSTICK HOLDERS
MATERIAL Black textile pouch
FEATURE Strong mounting clamp
FINISHES **MC-DSH:** MEINL
MC-DSH-JB: Jawbreaker motif

12 CYMBAL STACKERS
SIZES **MC-CYS:** ø 6 mm, long
MC-CYS8: ø 8 mm, long
MC-CYS8-S: ø 8 mm, short
FEATURE Felt washers

13 CYMBAL HOLDER
FEATURES Knurled surface
Felt washers

14 CYMBAL ATTACHMENT
FEATURES Multi-clamp
Cymbal boom arm

MULTI CLAMPS 15 16 17
FEATURES Length adjustable
Strong mounting clamp

15 MULTI CLAMP, ONE MOUNT
INCLUDES Straight rod

16 MULTI CLAMP, TWO MOUNTS
INCLUDES 2 straight rods

17 MULTI CLAMP, FOUR MOUNTS
INCLUDES 2 straight rods
2 angled rods

18 RODS
SHAPES Angled rod, Straight rod, Z-shaped rod
FEATURE Knurled surface

19 CLAMP
FEATURE Compact and solid design

20 PEDAL MOUNT
MATERIAL Black powder coated steel
FEATURES Height adjustable legs
Metal spikes attached to the bottom
INCLUDES 2 differently sized L-rods

21 MOUNTING BAR, SIX PCS.
INCLUDES 2 straight rods
2 angled rods
2 Z-shaped rods



1 **MCOB-11 MCOB-1134 MCOB-1212**

ADDITIONAL UPRIGHT ZIPPER



2 **MSTCOB**

NEW!

FITS FOR ALL SIZES



3 **MSTBB1**



4 **MBB**



5 **MTB**



6 **MCHB**

2 INTERNAL POCKETS WITH INNER HOOK AND LOOP FASTENER STRAPS



7 **10" DCAP-M 12" DCAP-L 13" DCAP-XL**



8 **MDJB-L MDJB-M MDJB-S**



9 **MDLXDJB-M MDLXDJB-L**

SYNTHETIC FUR FOR EXTRA PROTECTION



10 **MSTDJB**

NEW!

FITS FOR ALL SIZES

PROFESSIONAL MEINL BAGS

All Professional MEINL Bags are made from heavy duty nylon with reinforced stitching. They protect your instruments and assure hassle free transportation.

1 PROFESSIONAL CONGA BAGS

An extra top zipper simplifies packing and unpacking of your drum. Additional features are padded backpack straps and an external pocket for accessories.

MATERIAL Heavy duty nylon
SIZES 11", 11 3/4", 12 1/2"

FEATURES Additional upright zipper
External pocket
Padded backpack straps
Carrying grip

2 CONGA GIG BAG

The MEINL Conga Gig Bag fits for all sizes. Featuring a carrying grip and a shoulder strap for easy transportation.

MATERIAL Heavy duty nylon

FEATURES Carrying grip
Shoulder strap
Outer pocket

3 BONGO GIG BAG

MATERIAL Heavy duty nylon

SIZE Bongos up to 7 1/2" Macho & 8 1/2" Hembra

FEATURE Carrying grip

4 PROFESSIONAL BONGO BAG

MATERIAL Heavy duty nylon

FEATURES Additional room for accessories
Padded shoulder strap
Carrying grip, Padded separator

5 PROFESSIONAL TIMBALES BAG

MATERIAL Heavy duty nylon

SIZES 14" & 15"

FEATURES External pocket for stand and cowbell
Padded shoulder strap
Carrying grip
Padded separator

6 PROFESSIONAL CHIMES BAG

MATERIAL Heavy duty nylon

FEATURES Stores up to 2 chimes
Carrying grip
Inner hook and loop fastener straps
2 internal pockets

7 PROFESSIONAL DJEMBE CAPS

These caps protect your drum with a heavy duty reinforced top and an extra-long skirt with an elastic waist band.

MATERIAL Heavy duty nylon

SIZES **M:** 10", **L:** 12", **XL:** 13"

COLOUR Black

8 PROFESSIONAL DJEMBE BAGS

MATERIAL Heavy duty nylon

SIZES Small (up to 10")
Medium (up to 12")
Large (up to 13 1/2")

FEATURES External pocket
Carrying grip
MDJB-M, MDJB-L:
Padded backpack straps

9 DELUXE DJEMBE BAGS

MATERIAL Heavy duty nylon

SIZES Medium (up to 12")
Large (up to 13 1/2")

FEATURES Synthetic fur
External pocket
Padded backpack straps
Carrying grip

10 DJEMBE GIG BAG

The MEINL Djembe Gig Bag fits for all sizes. Featuring a carrying grip and a shoulder strap for easy transportation.

MATERIAL Heavy duty nylon

FEATURES Carrying grip
Shoulder strap
Outer pocket





10" x 10"
MREB-10 12" x 12"
MREB-12



6"
MQW-6 8"
MQW-7 10"
MQW-10



12" x 18"
MREBB-12



12" x 4 1/2"
MCA-12 12" x 6"
MCA-12T 14" x 4"
MCA-14

EXTRA POCKET FOR SPARE HEADS



14" x 28"
MTIMB-1428 14" x 35"
MTIMB-1435



14" x 28"
MTANB-14



16" x 20"
MSUB-16 18" x 22"
MSUB-18 20" x 24"
MSUB-20 22" x 24"
MSUB-22

1 PROFESSIONAL REPINIQUE BAGS

MATERIAL Heavy duty nylon
SIZES 10" x 10"
12" x 12"
FEATURES Double-slide zipper
Shoulder strap
Carrying grip
External pocket

2 PROFESSIONAL CUICA BAGS

MATERIAL Heavy duty nylon
SIZES 6", 8", 10"
FEATURES Padded shoulder strap
Carrying grip
External pocket

3 PROFESSIONAL REBOLO BAG

MATERIAL Heavy duty nylon
SIZE 12" x 18"
FEATURES Double-slide zipper
Padded shoulder strap
Carrying grip
External pocket

4 PROFESSIONAL CAIXA BAGS

MATERIAL Heavy duty nylon
SIZES 12" x 4 1/2"
12" x 6"
14" x 4"
FEATURES Double-slide zipper
Extra pocket for spare heads
Shoulder strap
Carrying grip
External pocket

5 PROFESSIONAL TIMBA BAGS

MATERIAL Heavy duty nylon
SIZES 14" x 28"
14" x 35"
FEATURES Double-slide zipper
Padded backpack straps
Carrying grip
External pocket

6 PROFESSIONAL TANTAM BAG

MATERIAL Heavy duty nylon
SIZE 14" x 28"
FEATURES Double-slide zipper
Padded backpack straps
Carrying grip
External pocket

7 PROFESSIONAL SURDO BAGS

MATERIAL Heavy duty nylon
SIZES 16" x 20"
18" x 22"
20" x 24"
22" x 24"
FEATURES Double-slide zipper
Padded backpack straps
Carrying grip
External pocket

1



MCJPC

3



MCJB

5



MDLXCJB-L

SYNTHETIC FUR FOR
ADDITIONAL PROTECTION

2



MSTCJB

4



MDLXCJB

6



MTREB

7



MSTTCAJB

1 PROTECTION COVER FOR HEADLINER® CAJONS

This protection cover offers dependable protection at an affordable price, assuring your cajon will look as good as it sounds for a long time to come.

MATERIAL Heavy duty nylon
COLOUR Black
FEATURE Fits for all HCA1 models

2 CAJON GIG BAG

MATERIAL Heavy duty nylon
MEASURES 20 1/2" W x 12" H x 12" D
FEATURE Carrying grip

3 PROFESSIONAL CAJON BAG

MATERIAL Heavy duty nylon
MEASURES 20 1/2" W x 12" H x 12" D

FEATURES Padded shoulder strap
External pocket
Carrying grip

4 DELUXE CAJON BAG

The MEINL Deluxe Cajon Bag features an additional layer of synthetic fur, which removes surface moisture and provides extra protection. Additional features are a padded shoulder strap and an external pocket for accessories.

MATERIAL Heavy duty nylon
MEASURES 20 1/2" W x 12" H x 12" D

FEATURES Synthetic fur
Padded shoulder strap
External pocket
Carrying grip

5 DELUXE BASS PEDAL CAJON BAG

The MEINL Deluxe Cajon Bag is perfectly suited for the bigger sized Bass Pedal Cajon.

MATERIAL Heavy duty nylon
MEASURES 21 1/2" W x 17" H x 14 1/2" D

FEATURES Synthetic fur
Padded shoulder strap
External pocket
Carrying grip

6 PROFESSIONAL TREJON/MARIMBULA BAG

MATERIAL Heavy duty nylon
MEASURES 21" W x 20" H x 18" D

FEATURES Extra padding for security
External pockets for small percussion
Padded backpack straps

8



16" x 2 1/2"
MFDB-16

18" x 2 1/2"
MFDB-18

20" x 2 1/2"
MFDB-20

22" x 2 1/2"
MFDB-22

11



12" x 4"
MFDB-12BE

14" x 4"
MFDB-14BE

14" x 6"
MFDB-14IBO

18" x 4"
MFDB-18BO

22" x 4"
MFDB-22-D

7 TRAVEL CAJON GIG BAG

MATERIAL Heavy duty nylon
SIZE 12"
FEATURES Double-slide zipper
Carrying grip

8 PROFESSIONAL FRAME DRUM BAGS

MATERIAL Heavy duty nylon
SIZES 16", 18", 20", 22"
2 1/2" deep
FEATURES Double-slide zipper
Shoulder strap, Carrying grip

9 PROFESSIONAL KANJIRA BAG

MATERIAL Heavy duty nylon
SIZE 8 1/2" x 2 1/2"
FEATURES Double-slide zipper
Shoulder strap, External pocket

10 PROFESSIONAL TAMBORIM BAG

MATERIAL Heavy duty nylon
SIZE 6"
FEATURES Double-slide zipper
Shoulder strap
External pocket

11 PROFESSIONAL DEEP SHELL FRAME DRUM BAGS

MATERIAL Heavy duty nylon
SIZES **MFDB-12BE:** 12" x 4"
MFDB-14BE: 14" x 4"
MFDB-14IBO: 14" x 6"
MFDB-18BO: 18" x 4"
MFDB-22-D: 22" x 4"
FEATURES Double-slide zipper
Shoulder strap
Carrying grip

9



8 1/2" x 2 1/2"
MFDB-7KA

10



6"
MTAB-06

PERFECT FIT

12



10"
MPAB-10

12"
MPAB-12

ALSO FITS FOR OUR
10" TAMBORINES

13



10"
MSTTB

12 PROFESSIONAL PANDEIRO BAGS

MATERIAL Heavy duty nylon
SIZES 10", 12"
FEATURES Double-slide zipper
Shoulder strap
External pocket

13 TAMBORINE GIG BAG

MATERIAL Heavy duty nylon
SIZE 10"
FEATURES Sturdy zipper
Carrying grip



MDAB



MDOB



MDDGB



MDDGB-PRO



MIB-S

MIB-M

MIB-L



MDLXSB



MSB-1

MSB-1-C1

MSB-1-JB

SPACIOUS STICK COMPARTMENT FOR QUICK ACCESS



MSTCB22



MCB22

MCB22-C1

MCB22-JB



MCB22/MSB

CYMBALS AND STICKS ARE ALWAYS READY AT HAND



MCB22/MSB-C1



MCB22-BP

1 PROFESSIONAL DARBUKA BAG

MATERIAL Heavy duty nylon
FEATURES Double-slide zipper
 Additional upright zipper
 Padded shoulder strap
 Carrying grip
 External pocket

SIZE 53"
FEATURES Padded shoulder strap
 External pocket

2 PROFESSIONAL DOUMBEEK BAG

MATERIAL Heavy duty nylon
FEATURES Double-slide zipper
 Additional upright zipper
 Padded shoulder strap
 Carrying grip
 External pocket

4 PRO DIDGERIDOO BAG
MATERIAL Heavy duty nylon
SIZE 58"
FEATURES Padded shoulder strap
 External pocket

3 STRAIGHT DIDGERIDOO BAG

MATERIAL Heavy duty nylon

5 PROFESSIONAL IBO BAGS
MATERIAL Heavy duty nylon
SIZES Small (9 3/4" W x 13 1/3" H x 9 3/4" D)
 Medium (11" W x 14 1/2" H x 11" D)
 Large (11 3/4" W x 15" H x 11 3/4" D)
INCLUDES Padded shoulder strap
 Carrying grip
 External pocket

6 PROFESSIONAL STICK BAGS

MATERIALS **MSB-1, MSB-1-C1:** Heavy duty nylon
MSB-1-JB: Leatherette
FEATURES External pockets
 Shoulder straps
 Extension straps
COLOURS Black
 Jawbreaker
 Original Camouflage

7 DELUXE STICK BAG

MATERIAL Padded synthetic leather
FEATURES External pockets
 Shoulder straps
 Elastic cord attachments
COLOUR Black

8 CYMBAL GIG BAG

The MEINL Cymbal Gig Bag holds cymbals up to 22" in diameter. It is produced in a high quality standard at an affordable price.
MATERIAL Heavy duty nylon
SIZE 22"
FEATURES Shoulder strap
 Carrying grip
COLOUR Black

9 PROFESSIONAL CYMBAL BAGS

The Meinl 22" Professional Cymbal Bags are available in 3 different finishes. They have a small external pocket for other Drum Gear and an external hihat / splash compartment designed to hold cymbals up to 15" in diameter.
MATERIALS **MCB22, MCB22-C1:** Heavy duty nylon
MCB22-JB: Leatherette

SIZE 22"
FEATURES Padded dividers
 Padded shoulder strap
COLOURS Black
 Jawbreaker
 Original Camouflage

10 COMBO BAGS

An exceptional combination of a Meinl 22" Cymbal Bag and a Meinl Stick Bag. They come together from a zipper on the backside. Cymbals and sticks are always ready at hand.
MATERIAL Heavy duty nylon
SIZE 22"
FEATURES External compartment
 Padded dividing pads
 Padded shoulder strap
 Carrying grip

COLOURS Black
 Original Camouflage

11 PROFESSIONAL CYMBAL BACKPACK

The 22" Cymbal Bag has two backpack straps on the backside for easy transportation. External hihat/splash compartment which holds cymbals up to 15" in diameter, includes a glow-in-the-dark Meinl logo for spotting your bag in darkly lit venues.
MATERIAL Heavy duty nylon
SIZE 22"
FEATURES External hihat / splash compartment
 Glow-in-the-dark Meinl logo
 Two backpack straps on the backside
COLOUR Black



T-Shirt
M42



T-Shirt
M42P



Jawbreaker
T-Shirt
M85



Jawbreaker
long sleeve
M86



Polo shirt
M25



Polo shirt
M28P



Hood shirt
w/ zipper
M48



Hood shirt
M48P



Jawbreaker
Hood shirt w/ zipper
M88



Jawbreaker
Hood shirt
M87



Training
jacket
M73



Training
jacket
M71P



Tour Trolley
T-PBT-BK



Army cap, black
M20

Army cap, khaki
M21



Mouse Pad
M59



Gig Towel, medium
MEI-HANDTUCH2



Gig Towel, large
MEI-HANDTUCH3



Bar stool, 24"
MBS24

Bar stool, 30"
MBS30



Jawbreaker Sling Bag
M-BAG-BK-JB

Jawbreaker Sling Bag
M-BAG-JB



Lanyard
M22

Support your favourite percussion brand with the official MEINL swag. A selection of exclusive items made from the highest quality materials.

- 1 T-SHIRT**
SIZES S, M, L, XL, XXL
COLOUR Black
FRONT MEINL logo, small
BACK MEINL logo, big
- 2 T-SHIRT (MADE BY PUMA)**
SIZES S, M, L, XL, XXL
COLOUR Black
FRONT Embroidered small MEINL logo and PUMA logo

- 3 JAWBREAKER T-SHIRT**
SIZES S, M, L, XL
COLOUR Black
FRONT Jawbreaker
- 4 JAWBREAKER LONG SLEEVE**
SIZES S, M, L, XL
COLOUR Black
FRONT Jawbreaker
- 5 POLO SHIRT**
SIZES S, M, L, XL, XXL
COLOUR Black
FRONT MEINL logo, small

- 6 POLO SHIRT (MADE BY PUMA)**
SIZES S, M, L, XL, XXL
COLOUR Black
FRONT Embroidered small MEINL logo and PUMA logo
- 7 HOOD SHIRT W/ ZIPPER**
SIZES S, M, L, XL, XXL
COLOUR Black
FRONT MEINL logo, small
BACK MEINL logo, big
- 8 HOOD SHIRT (MADE BY PUMA)**
SIZES S, M, L, XL, XXL
COLOUR Black
FRONT Embroidered small MEINL logo and PUMA logo

- 9 JAWBREAKER HOOD SHIRT W/ ZIPPER**
SIZES S, M, L, XL, XXL
COLOUR Black
FRONT MEINL logo, small
BACK Jawbreaker
- 10 JAWBREAKER HOOD SHIRT**
SIZES S, M, L, XL, XXL
COLOUR Black
FRONT MEINL logo, small
BACK Jawbreaker
- 11 TRAINING JACKET**
SIZES S, M, L, XL, XXL
COLOUR Black
FRONT MEINL logo, small
BACK MEINL logo, big

- 12 TRAINING JACKET (MADE BY PUMA)**
SIZES S, M, L, XL, XXL
COLOUR Black
FRONT Embroidered small MEINL logo and PUMA logo
- 13 TOUR TROLLEY**
- 14 ARMY CAPS**
COLOURS Black
Khaki
- 15 MOUSE PAD**
- 16 GIG TOWELS**
SIZES Medium
Large

- 17 BAR STOOLS**
SIZES 24", 30"
- 18 JAWBREAKER SLING BAGS**
COLOURS **M-BAG-BK-JB:** Black
M-BAG-JB: Red
- 19 LANYARD**



JOIN OUR SOCIAL NETWORK

Unlike most companies MEINL is not just about the business. We are focused on you... the players... those who make music with our instruments. With all of the new social networks this has become much easier. We invite you to send us ideas, questions, or comments. You can find us on Facebook, Google+, Youtube and Twitter.

P.S. Be sure to check out meinlpercussion.com for the latest news.

meinlpercussion.com

PRODUCTS ARTISTS COMPANY



facebook.com/meinlpercussionfanpage



twitter.com/meinlpercussion

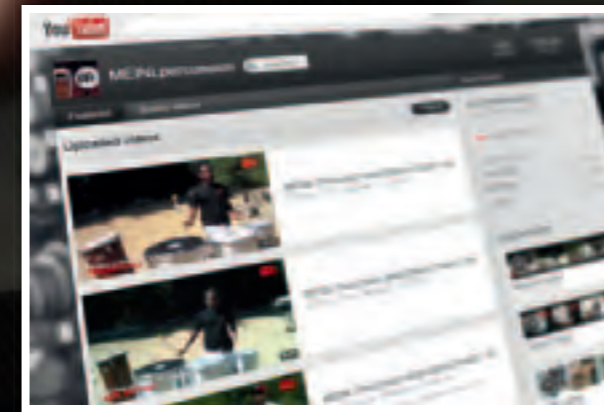

youtube.com/meinlpercussion



gplus.to/meinlpercussion

MEINL PERCUSSION THE ULTIMATE SELECTION

OCTOBER 23 via News
MEINL TIMBALES ARE ON FIRE WITH HUSSEIN

Hussein Abdala is now part of the family.





MEINL REPLACEMENT PARTS

REPLACEMENT PARTS																					
Model No.	Size	Height	Material	Features	Head	Rim	Lug	Bracket	Page												
CONGAS																					
																					
<table border="1"> <tr> <td>Rubber Wood</td> <td>Premium Fiberglass</td> <td>American White Ash</td> <td>True Skin Buffalo Heads</td> <td>SSR-Rim</td> <td>TTR-Rim</td> <td>Conga Saver</td> <td>Floatune Tuning System</td> <td></td> <td></td> <td></td> </tr> </table>											Rubber Wood	Premium Fiberglass	American White Ash	True Skin Buffalo Heads	SSR-Rim	TTR-Rim	Conga Saver	Floatune Tuning System			
Rubber Wood	Premium Fiberglass	American White Ash	True Skin Buffalo Heads	SSR-Rim	TTR-Rim	Conga Saver	Floatune Tuning System														
HEADLINER® SERIES WOOD CONGA SETS																					
HC512 (incl. Basket Stand)	11" + 12"	28"	X		X				HHEAD11/HHEAD12C	HRIM11/HRIM12C	HCLUG	HCBRACKET-02	019-021								
HC555 (incl. Basket Stand)	10" + 11"	28"	X		X				HHEAD10/HHEAD11	HRIM10/HRIM11	HCLUG	HCBRACKET-02	019-021								
HEADLINER® DESIGNER SERIES CONGAS																					
HC10 (incl. Basket Stand)	10"	28"	X		X				HHEAD10	HRIM10	HCLUG	HCBRACKET-02	022								
HC11 (incl. Basket Stand)	11"	28"	X		X				HHEAD11	HRIM11	HCLUG	HCBRACKET-02	022								
HC12 (incl. Basket Stand)	12"	28"	X		X				HHEAD12C	HRIM12C	HCLUG	HCBRACKET-02	022								
HEADLINER® TRADITIONAL DESIGNER SERIES CONGAS																					
HTC10 (incl. Basket Stand)	10"	28"	X		X				HHEAD10T	HRIM10T	HCLUG	HCBRACKET-02	023								
HTC11 (incl. Basket Stand)	11"	28"	X		X				HHEAD11T	HRIM11T	HCLUG	HCBRACKET-02	023								
HTC12 (incl. Basket Stand)	12"	28"	X		X				HHEAD12T	HRIM12T	HCLUG	HCBRACKET-02	023								
HEADLINER® SERIES CONGA SETS																					
HC812 (incl. Double Stand)	11" + 12"	28"	X		X				HHEAD11/HHEAD12C	HRIM11/HRIM12C	HCLUG	HCBRACKET-02	024/025								
HC888 (incl. Double Stand)	10" + 11"	28"	X		X				HHEAD10/HHEAD11	HRIM10/HRIM11	HCLUG	HCBRACKET-02	024/025								
MARATHON® CLASSIC SERIES CONGA SET																					
MCC-SET-ATB-M (incl. Double Stand)	11" + 11 3/4"	30"	X		X	X	X		TS-B-38/TS-B-39	SSR-25/SSR-26	LUG-03	BRACKET-15	025								
HEADLINER® FIBERGLASS SERIES CONGAS																					
HFC10 (incl. Basket Stand)	10"	28"	X		X				HHEAD10	HRIM10	HCLUG	HCBRACKET-02	026								
HFC11 (incl. Basket Stand)	11"	28"	X		X				HHEAD11	HRIM11	HCLUG	HCBRACKET-02	026								
HFC12 (incl. Basket Stand)	12"	28"	X		X				HHEAD12C	HRIM12C	HCLUG	HCBRACKET-02	026								
ARTIST SERIES, LUIS CONTE																					
LC11	11"	30"	X		X	X	X		TS-B-52	TTR-28	LUG-03	BRACKET-20	026								
LC1134	11 3/4"	30"	X		X	X	X		TS-B-53	TTR-29	LUG-03	BRACKET-20	026								
LC1212	11 1/2"	30"	X		X	X	X		TS-B-54	TTR-30	LUG-03	BRACKET-20	026								
MARATHON® CLASSIC SERIES / DESIGNER SERIES																					
MCC11 (incl. Steely-II Stand)	11"	30"	X		X	X	X		TS-B-38	SSR-25	LUG-03	BRACKET-15	027-029								
MCC1134 (incl. Steely-II Stand)	11 3/4"	30"	X		X	X	X		TS-B-39	SSR-26	LUG-03	BRACKET-15	027-029								
MCC1212 (incl. Steely-II Stand)	12 1/2"	30"	X		X	X	X		TS-B-40	SSR-27	LUG-03	BRACKET-15	027-029								
PROFESSIONAL SERIES																					
MP11	11"	30"	X		X	X	X		TS-B-34	SSR-22	LUG-01	BRACKET-14	030/031								
MP1134	11 3/4"	30"	X		X	X	X		TS-B-35	SSR-23	LUG-01	BRACKET-14	030/031								
MP1212	12 1/2"	30"	X		X	X	X		TS-B-36	SSR-24	LUG-01	BRACKET-14	030/031								
FIBERCRAFT SERIES / DESIGNER SERIES																					
FC11	11"	30"	X		X	X	X		TS-B-34	SSR-22	LUG-01	BRACKET-14	032/033								
FC1134	11 3/4"	30"	X		X	X	X		TS-B-35	SSR-23	LUG-01	BRACKET-14	032/033								
FC1212	12 1/2"	30"	X		X	X	X		TS-B-36	SSR-24	LUG-01	BRACKET-14	032/033								
FLOATUNE SERIES																					
FL10	10"	30"	X		X	X	X		TS-B-01	SSR-06	LUG-01		034								
FL11	11"	30"	X		X	X	X		TS-B-03	SSR-07	LUG-01		034								
FL12	12"	30"	X		X	X	X		TS-B-15	SSR-12	LUG-01		034								
FL13	13"	30"	X		X	X	X		TS-B-21	SSR-15	LUG-01		034								
ARTIST SERIES, MONGO SANTAMARIA																					
MSA11	11"	30"			X	X	X		TS-B-07	SSR-08	LUG-02	BRACKET-16	034								
MSA1134	11 3/4"	30"			X	X	X		TS-B-11	SSR-10	LUG-02	BRACKET-16	034								
MSA1212	12 1/2"	30"			X	X	X		TS-B-17	SSR-13	LUG-02	BRACKET-16	034								
WOODCRAFT SERIES																					
WC11	11"	30"			X	X	X		TS-B-44	TTR-23	LUG-01	BRACKET-14	035								
WC1134	11 3/4"	30"			X	X	X		TS-B-45	TTR-24	LUG-01	BRACKET-14	035								
WC1212	12 1/2"	30"			X	X	X		TS-B-46	TTR-25	LUG-01	BRACKET-14	035								

REPLACEMENT PARTS FOR STANDS		
10" Basket Stand for HC555 / Designer Series / Fiberglass Series	HSTAND10	019-026
11" Basket Stand for HC555 / HC512 / Designer Series / Fiberglass Series	HSTAND11	019-026
12" Basket Stand for HC512 / Designer Series / Fiberglass Series	HSTAND12	019-026
Rubber Feet (set of 3 pcs.) for Steely-II Stand	STAND-35	166
Rubber Tops (set of 3 pcs.) for Steely-II Stand	STAND-21	166
Screw Set complete for Steely-II Stand, black	STAND-22	166
Screw Set complete for Steely-II Stand, chrome	STAND-23	166
Screw Set complete for Steely-II Stand, gold tone	STAND-24	166
Socket Screw (set of 2 pcs.) black	STAND-26	166
Socket Screw (set of 2 pcs.) chrome	STAND-27	166
Socket Screw (set of 2 pcs.) gold tone	STAND-28	166
Brackets for HDSTAND and TMS	HDBRACKET-04	166

OTHER PARTS		
Lug Oil	SPARE-09	
Conga Saver for 8 mm Lugs (set of 6 pcs.)	CONGA-SAVER8	
Conga Saver for 10 mm Lugs (set of 6 pcs.)	CONGA-SAVER10	
Tuning Key, 13 mm + 14 mm, L shaped, gold tone	KEY-01	
Tuning Key, 13 mm + 14 mm, L shaped, chrome	KEY-02	

REPLACEMENT PARTS																					
Model No.	Size	Material	Features	Head	Rim	Lug	Bracket	Page													
BONGOS																					
																					
<table border="1"> <tr> <td>Acrylic</td> <td>ABS Plastic</td> <td>American White Ash</td> <td>Rubber Wood</td> <td>Plywood</td> <td>Premium Fiberglass</td> <td>True Skin Cow Heads</td> <td>True Skin Buffalo Heads</td> <td>SSR-Rim</td> <td>TTR-Rim</td> <td>Free Ride System</td> </tr> </table>											Acrylic	ABS Plastic	American White Ash	Rubber Wood	Plywood	Premium Fiberglass	True Skin Cow Heads	True Skin Buffalo Heads	SSR-Rim	TTR-Rim	Free Ride System
Acrylic	ABS Plastic	American White Ash	Rubber Wood	Plywood	Premium Fiberglass	True Skin Cow Heads	True Skin Buffalo Heads	SSR-Rim	TTR-Rim	Free Ride System											
HEADLINER® SERIES ABS BONGO / ACRYLIC BONGO																					
HB50	6 1/2"	X	X						HHEAD6,5	RIM-NI3-65-BK	LUG-NINO3		038/039								
HB50	7 1/2"	X	X						HHEAD7,5	RIM-NI3-75-BK	LUG-NINO3		038/039								
HEADLINER® SERIES WOOD BONGOS / DESIGNER / FIBERGLASS SERIES / TRADITIONAL																					
HB100	6 3/4"			X					HHEAD634W	HRIM634W	HBLUG		038/039								
HB100	8"			X					HHEAD8W	HRIM8W	HBLUG		038/039								
HFB100	6 3/4"				X				HHEAD634W	HRIM634W	HBLUG		039								
HFB100	8"				X				HHEAD8W	HRIM8W	HBLUG		039								
HTB100	6 3/4"			X					HHEAD634T	HBRIM634T	HBLUG		039								
HTB100	8"			X					HHEAD8T	HBRIM8T	HBLUG		039								
FREE RIDE SERIES FWB190 WOOD BONGOS / DESIGNER SERIES																					
FWB190	6 3/4"		X			X	X		HEAD-38	SSR-18	LUG-22		040								
FWB190	8"		X			X	X		HEAD-39	SSR-19	LUG-22		040								
FREE RIDE SERIES MINI WOOD BONGOS																					
FWB100	3 1/2"		X		X	X	X		TS-B-31	SSR-16	LUG-19		041								
FWB100	4 1/4"		X		X	X	X		TS-B-32	SSR-17	LUG-19		041								
FREE RIDE SERIES FWB200 WOOD BONGOS																					
FWB200	6 3/4"		X			X	X		HEAD-38	SSR-20	LUG-22		041								
FWB200	8"		X			X	X		HEAD-39	SSR-21	LUG-22		041								
LUIS CONTE ARTIST SERIES WOOD BONGO																					
LC300	6 3/4"		X		X	X	X		TS-C-13	TTR-31	LUG-22		041								
LC300	8"		X		X	X	X		TS-C-14	TTR-32	LUG-22		041								
FREE RIDE SERIES FFB200 FIBERGLASS BONGOS																					
FFB200	6 3/4"			X		X	X		TS-B-50	SSR-34	LUG-23		042								
FFB200	8"			X		X	X		TS-B-51	SSR-35	LUG-23		042								
FREE RIDE SERIES FFB400 FIBERGLASS BONGOS / DESIGNER SERIES																					
FFB400	7"			X	X	X	X		TS-C-02	SSR-02	LUG-07		042								
FFB400	8 1/2"			X	X	X	X		TS-C-03	SSR-04	LUG-07		042								
FREE RIDE SERIES FWB400 WOOD BONGO																					
FWB400	7"		X		X	X	X		TS-C-02	SSR-02	LUG-07		043								
FWB400	8 1/2"		X		X	X	X		TS-C-03	SSR-04	LUG-07		043								
FREE RIDE SERIES COLLECTION WOOD BONGO																					
CS400	7"		X		X	X	X		TS-C-02	SSR-02	LUG-07		043								
CS400	8 1/2"		X		X	X	X		TS-C-03	SSR-04	LUG-07		043								
FREE RIDE SERIES WOODCRAFT BONGO																					
WB500	7"		X		X	X	X		TS-C-11	TTR-26	LUG-07		043								
WB500	9"		X		X	X	X		TS-C-12	TTR-27	LUG-07		043								
MEINL RAPC BONGO																					
MB400	6 3/4"			X		X	X		HEAD-38	SSR-20	LUG-22		045								
MB400	8"			X		X	X		HEAD-39	SSR-21	LUG-22		045								

REPLACEMENT PARTS FOR STANDS		
Memory Clamp, chrome, for middle stand tube for TMB + TMB-S	STAND-07	167
Memory Clamp, chrome, for lower stand tube for TMB + TMB-S	STAND-09	167
Memory Clamp, chrome, for upper stand tube for TMB	STAND-11	167
Fast Lock Set, chrome for TMB + TMB-S	STAND-14	167
Rubber Feet (set of 3 pcs.) for all Bongo Stands	STAND-16	167
L-Shaped Clamp for top part for TMB + TMB-S	STAND-18	167
Upper Stand Section, complete for TMB	STAND-34	167

OTHER PARTS		
Lug Oil	SPARE-09	
Tuning Key, 13 mm + 14 mm, L-shaped, chrome	KEY-02	

REPLACEMENT PARTS			
Model No.	Name	Model No.	Page
FOOT CABASA / TRIANGLES			
			
FOOT CABASA			
FCA5-L	Coil springs	SPARE-20	092
FCA5-L	Regular spring	SPARE-26	092
FCA5-L	Cabasa complete	SPARE-35	092
FCA5-L	Stopper	SPARE-43	092
TRIANGLES			
TRI10B	Beater	SPARE-31	145
TRI15B	Beater	SPARE-31	145
TRI20B	Beater	SPARE-31	145
JCTRI20	Beater	SPARE-31	145



MEINL REPLACEMENT PARTS

REPLACEMENT PARTS													
Model No.	Size	Height	Material	Features	Head	Rim	Lug	Bracket	Page				
DJEMBES													
													
Mahogany Wood Rubber Wood Premium Fiberglass American White Ash Synthetic Heads Goat Heads Cow Heads True Skin Goat Heads True Skin Calf Heads Floatune Tuning System Rope Tuning System SSR-Rim Traditional Rim													
HEADLINER® SERIES ROPE TUNED WOOD DJEMBES NILE SERIES													
HDJ4-S	8"	15 3/4"	X		X				HEAD-61	048			
HDJ4-M	10"	20"	X		X				HEAD-53	048			
HDJ4-L	12"	24"	X		X				HEAD-54	048			
HDJ4-XL	13"	25"	X		X				HEAD-55	048			
HEADLINER® SERIES ROPE TUNED WOOD DJEMBES BLACK RIVER SERIES													
HDJ3-S	8"	15 3/4"	X		X				HEAD-61	048			
HDJ3-M	10"	20"	X		X				HEAD-53	048			
HDJ3-L	12"	24"	X		X				HEAD-54	048			
HDJ3-XL	13"	25"	X		X				HEAD-55	048			
HEADLINER® SERIES ROPE TUNED WOOD DJEMBES CONGO SERIES													
HDJ1-S	8"	15 3/4"	X		X				HEAD-61	049			
HDJ1-M	10"	20"	X		X				HEAD-53	049			
HDJ1-L	12"	24"	X		X				HEAD-54	049			
HDJ1-XL	13"	25"	X		X				HEAD-55	049			
HEADLINER® SERIES ROPE TUNED WOOD DJEMBES TRIBAL SERIES													
HDJ2-S	8"	15 3/4"	X		X				HEAD-61	049			
HDJ2-M	10"	20"	X		X				HEAD-53	049			
HDJ2-L	12"	24"	X		X				HEAD-54	049			
HDJ2-XL	13"	25"	X		X				HEAD-55	049			
ORIGINAL AFRICAN STYLE ROPE TUNED WOOD DJEMBES													
ADJ2, 3, 4-M+BAG	10"	20"	X		X				HEAD-53	050/051			
ADJ2, 3, 4-L+BAG	12"	24"	X		X				HEAD-54	050/051			
ADJ2, 3, 4-XL+BAG	13"	25"	X		X				HEAD-55	050/051			
AFRICAN BOUGARABOU													
ABGB-L	12"	24"	X		X				HEAD-63	052			
PROFESSIONAL AFRICAN STYLE DJEMBES / DELUXE AFRICAN STYLE DJEMBES													
PROADJ1	12"	24"	X		X				HEAD-54	052			
PROADJ2	12"	24"	X		X				HEAD-54	052			
PROADJ3	14"	26"	X		X				HEAD-56	052			
PROADJ4	12"	24"	X		X				HEAD-54	052			
DJEMBEFOLAS													
DJFS1-M	10"	20"	X		X				HEAD-97	053			
DJFS1-L	12"	24"	X		X				HEAD-97	053			
JOURNEY SERIES ROPE TUNED FIBERGLASS DJEMBES, SYNTHETIC HEAD													
FADJ1, 2, 5, 6, 7-M	10"	18"	X	X					HEAD-70	054			
FADJ1, 2, 5, 6, 7-L	12"	24"	X	X					HEAD-71	054			
JOURNEY SERIES ROPE TUNED FIBERGLASS DJEMBES, GOAT HEAD													
FADJ1, 2, 5, 6, 7-M-G	10"	18"	X	X					HEAD-88	055			
FADJ1, 2, 5, 6, 7-L-G	12"	24"	X	X					HEAD-89	055			
MECHANICAL TUNED FIBERGLASS DJEMBE, SYNTHETIC HEAD													
FMDJ1, 2, 5, 6, 7-M-F	10"	18"	X	X				X	HEAD-90	RIM-55	BRACKET-27	BRACKET-27	056
FMDJ1, 2, 5, 6, 7-L-F	12"	24"	X	X				X	HEAD-91	RIM-56	BRACKET-27	BRACKET-27	056
MECHANICAL TUNED FIBERGLASS DJEMBE, GOAT HEAD													
FMDJ1, 2, 5, 6, 7-M-G	10"	18"	X	X				X	HEAD-92	RIM-55	BRACKET-27	BRACKET-27	057
FMDJ1, 2, 5, 6, 7-L-G	12"	24"	X	X				X	HEAD-93	RIM-56	BRACKET-27	BRACKET-27	057
PROFESSIONAL FIBERGLASS DJEMBES													
PROFADJ1-M	10"	20"	X	X					HEAD-70	058			
PROFADJ1-L	12"	24"	X	X					HEAD-71	058			
HEADLINER® SERIES WOOD DJEMBES													
HDJ500	12 1/2"	25 1/4"	X		X				HHEAD12,5W	HRIM12,5W	HDLUGW	HDBRACKET-02	060
FLOATUNE SERIES FIBERGLASS DJEMBES													
DJF3	12"	24 1/4"	X		X	X	X		TS-G-01	SSR-29	LUG-05		060
FLOATUNE SERIES 12" WOOD DJEMBES													
DJW3	12"	24 1/4"	X	X		X	X	X	TS-G-01	SSR-29	LUG-04		060/061
FLOATUNE SERIES 12 3/4" WOOD DJEMBES													
DJW2	12 3/4"	25 1/4"	X		X	X	X	X	TS-G-02	SSR-30	LUG-04		061
REPLACEMENT PARTS FOR STANDS													
Rubber Feet (set of 3 pcs.) for Steely-II Stand					STAND-35		168						
Rubber Tops (set of 3 pcs.) for Steely-II Stand					STAND-21		168						
Socket Screw (set of 2 pcs.) chrome					STAND-27		168						
Fast Lock Set, chrome					STAND-14		168						
Rubber Feet (set of 3 pcs.) for Djembe Stand					STAND-16		168						
OTHER PARTS													
Lug Oil					SPARE-09								
Tuning Key, 13 mm + 14 mm, L-shaped, chrome					KEY-02								

REPLACEMENT PARTS													
Model No.	Size	Material	Features	Head	Rim	Lug	Bracket	Page					
DARBUKAS & DOUMBES													
													
Aluminum Copper Rubber Wood Premium Fiberglass Synthetic Heads Hand selected buffalo heads Natural rawhide True Skin Buffalo Heads TTR-Rim Hand hammered shell Hand engraved shell													
ALUMINUM DARBUKAS													
HE-100	5 1/3"	X		X					HE-HEAD-100	HE-RIM-100	HE-LUG		064
HE-101	5 7/8"	X		X					HE-HEAD-101	HE-RIM-101	HE-LUG		064
HE-102	6 1/2"	X		X					HE-HEAD-102	HE-RIM-102	HE-LUG		064
HE-103	7 1/4"	X		X					HE-HEAD-103	HE-RIM-103	HE-LUG		064
HE-104	8"	X		X					HE-HEAD-104	HE-RIM-104	HE-LUG		064
HE-110	5 1/3"	X		X		X	X		HE-HEAD-100	HE-RIM-100	HE-LUG		064
HE-111	5 7/8"	X		X		X	X		HE-HEAD-101	HE-RIM-101	HE-LUG		064
HE-112	6 1/2"	X		X		X	X		HE-HEAD-102	HE-RIM-102	HE-LUG		064
HE-113	7 1/4"	X		X		X	X		HE-HEAD-103	HE-RIM-103	HE-LUG		064
HE-114	8"	X		X		X	X		HE-HEAD-104	HE-RIM-104	HE-LUG		064
HE-122	6 1/2"	X		X		X	X		HE-HEAD-102	HE-RIM-102	HE-LUG		065
HE-124	8"	X		X		X	X		HE-HEAD-104	HE-RIM-104	HE-LUG		065
ALUMINUM JINGLE DARBUKAS													
HE-314	8"	X		X		X	X		HE-HEAD-104	HE-RIM-104	HE-LUG		065
HE-315	8 1/4"	X		X		X	X		HE-HEAD-315	HE-RIM-105	HE-LUG		065
COPPER DARBUKAS													
HE-214	7 1/2"	X	X	X		X	X		HE-HEAD-214	HE-RIM-204	HE-LUG		065
HE-215	7 7/8"	X	X	X		X	X		HE-HEAD-215	HE-RIM-205	HE-LUG		065
HE-204	7 1/2"	X	X	X		X	X		HE-HEAD-204	HE-RIM-204	HE-LUG		065
HE-205	7 7/8"	X	X	X		X	X		HE-HEAD-205	HE-RIM-205	HE-LUG		065
FIBERGLASS DOUMBEK													
FDB3000G	8 1/2"		X	X		X			HEAD-80	RIM-FDB	LUG-FDB		066
ALUMINUM DOUMBES													
HE-3000	8 1/2"	X		X		X			HE-HEAD-3000	HE-RIM-3000	HE-LUG-3000		066
HE-3018	8 1/2"	X		X		X	X		HE-HEAD-3000	HE-RIM-3018	HE-LUG-3000		067
HE-3020	8 1/2"	X		X		X			HE-HEAD-3000	HE-RIM-3020	HE-LUG-3000		066
HE-3030	8 1/2"	X		X		X	X		HE-HEAD-3000	HE-RIM-3030	HE-LUG-3000		067
HE-3400	8 1/2"	X		X		X			HE-HEAD-3400	HE-RIM-3400	HE-LUG-3000		067
COPPER DOUMBEK													
HE-3012	8 1/2"	X	X	X		X	X		HE-HEAD-3000	HE-RIM-3020	HE-LUG-3000		067
ARTISAN EDITION DOUMBES													
AE-ED5	8 3/4"	X		X		X			HEAD-95	RIM-ED5	SPARE-41		069
AE-ED7	9"	X		X		X			HEAD-96	RIM-ED7	SPARE-41		069
AE-ED-5B	9"	X		X		X			HEAD-96	RIM-ED5	SPARE-41		069
RITUAL DRUMS													
													
Aluminum Copper Rubber Wood Premium Fiberglass Synthetic Heads Hand selected buffalo heads Natural rawhide True Skin Buffalo Heads TTR-Rim Hand hammered shell Hand engraved shell													
BATAS													
BA1	5 1/4"		X	X		X			HEAD-07	RIM-04	LUG-12		072
BA1	8"		X	X		X			HEAD-08	RIM-05	LUG-12		072
BA2	5 3/4"		X	X		X			HEAD-09	RIM-06	LUG-12		072
BA2	8 3/4"		X	X		X			HEAD-10	RIM-07	LUG-12		072
BA3	6 3/4"		X	X		X			HEAD-11	RIM-08	LUG-12		072
BA3	12"		X	X		X			HEAD-12	RIM-09	LUG-12		072
WOOD CONGUITAS													
HCG89	8"		X	X					HEAD-05	TTR-05	LUG-11	HDBRACKET-02	073
HCG89	9"		X	X					HEAD-06	TTR-08	LUG-11	HDBRACKET-02	073
TAMBORA													
MTA1	11"		X			X			TS-B-09 (NT)	RIM-03	LUG-10	BRACKET-06	073
MTA1	11"		X			X			TS-B-10 (WH)	RIM-03	LUG-10	BRACKET-06	073
OTHER PARTS													
BEATER (Rattan) for Talking Drum					SPARE-10		072						
BEATER (Mahogany Wood) for Talking Drum					SPARE-23		072						



MEINL REPLACEMENT PARTS

REPLACEMENT PARTS			
Model No.	Name	Model No.	Page
CAJONS			
HEADLINER® SERIES CAJONS			
HCAJ1NT	Frontplate	FP-HCAJ1NT	078
HCAJ3NT	Frontplate	FP-HCAJ3NT	078
HCAJ5NT	Frontplate	FP-HCAJ5NT	078
HCAJ1MH-M	Frontplate	FP-HCAJ1MH-M	078
HCAJ3MH-M	Frontplate	FP-HCAJ3MH-M	078
HCAJ5MH-M	Frontplate	FP-HCAJ5MH-M	078
HCAJ1AWA	Frontplate	FP-HCAJ1AWA	079
HCAJ3AWA	Frontplate	FP-HCAJ3AWA	079
HCAJ5AWA	Frontplate	FP-HCAJ5AWA	079
STRING CAJONS			
CAJ3MB-M	Frontplate	FP-CAJ3MB-M	080
CAJ3BMB-M	Frontplate	FP-CAJ3BMB-M	080
CAJ7NT-BK	Frontplate	FP-CAJ7NT-BK	080
CAJ3AWA	Frontplate	FP-CAJ3AWA	080
CAJ300BU-M	Frontplate	FP-CAJ300BU-M	081
SNARE CAJONS			
CAJ1SNT-M	Frontplate	FP-CAJ1SNT-M	082
CAJ1EB-M	Frontplate	FP-CAJ1EB-M	082
CAJ1CA-M	Frontplate	FP-CAJ1CA-M	082
CAJ2RO-M	Frontplate	FP-CAJ2RO-M	082
CAJ4RO-M	Frontplate	FP-CAJ4RO-M	082
CUSTOM CAJONS			
SUBCAJ1AWA	Frontplate	FP-SUBCAJ1AWA	088
TRECAJ2EB-M	Frontplate	FP-TRECAJ2EB	088
PEDAL CAJONS			
CAJ100BU-M	Frontplate	FP-CAJ100BU-M	083
CAJ5EB-M	Frontplate	FP-CAJ5EB-M	083
OTHER PARTS			
Snare for MEINL Snare Cajon		SPARE-38	
Pickup for MEINL Cajon, Shadow		SPARE-39	
String for MEINL String Cajon, set of 2 pcs.		SPARE-40	
Rubber feet for Cajon incl. Screw, set of 4 pcs.		SPARE-79	

REPLACEMENT PARTS									
Model No.	Size	Material	Features	Head	Rim	Lug	Bracket	Page	
FRAME DRUMS									
PLENERA SET									
PL-SET	8"		X	HEAD-75	RIM-51	LUG-43	BRACKET-24	124	
PL-SET	10"		X	HEAD-76	RIM-52	LUG-43	BRACKET-24	124	
PL-SET	12"		X	HEAD-77	RIM-53	LUG-43	BRACKET-24	124	
PANDEIROS									
PA10CN-M	10"	X	X	HEAD-44	RIM-33	LUG-24	BRACKET-19	125	
PA10ABS-BK	10"	X	X	HEAD-48	RIM-33	LUG-24	BRACKET-19	125	
PA10ABS-BK-NH	10"	X	X	HEAD-72	RIM-33	LUG-24	BRACKET-19	125	
PA12CN-M	12"	X	X	HEAD-45	RIM-34	LUG-24	BRACKET-19	125	
OTHER PARTS									
Tuning Key for Pandeiro				KEY-08					
Tuning Key for Frame Drums				KEY-11					
Protection Caps for Plenera lugs				CAPS-04					



REPLACEMENT PARTS									
Model No.	Size	Material	Features	Head	Rim	Lug	Bracket	Page	
DANCING PERCUSSION									
FIBERGLASS FAMILY DRUMS									
HFDD2	8"		X	HHEADHFDD	HRIMHFDD2	HFDDLUG	HDBRACKET-03	059	
FIBERGLASS DANCING CONGA									
HC301	8 1/2"		X	HHEAD8,5	HRIM8,5	HDCLUG	HDBRACKET-02	059	
FIBERGLASS DANCING DJEMBE									
HDJ400	12"		X	HHEAD12	HRIM12	HDLUG	HDBRACKET-02	059	
FIBERGLASS MINI DANCING DJEMBES									
HDJ200	8"		X	HHEADDJ8	HRIMDJ8	HD200LUG		059	

REPLACEMENT PARTS									
Model No.	Size	Material	Features	Head	Rim	Lug	Bracket	Page	
TIMBALES									
HEADLINER® SERIES									
HT1314, old version	13"		X	HEAD-24	RIM-37	LUG-26	BRACKET-18		
HT1314, old version	14"		X	HEAD-22	RIM-38	LUG-26	BRACKET-18		
HT1314, 2011 version	13"		X	HEAD-24	RIM-37	LUG-44	BRACKET-26	096	
HT1314, 2011 version	14"		X	HEAD-22	RIM-38	LUG-44	BRACKET-26	096	
MARATHON® SERIES									
MT1415CH + MT1415B	14"		X	HEAD-22	RIM-23	LUG-17	BRACKET-12	097	
MT1415CH + MT1415B	15"		X	HEAD-23	RIM-24	LUG-17	BRACKET-12	097	
MT1415BN + MT1415RR-M	14"		X	HEAD-22	RIM-27	LUG-17	BRACKET-25	097	
MT1415BN + MT1415RR-M	15"		X	HEAD-23	RIM-28	LUG-17	BRACKET-25	097	
MTT1415	14"		X	HEAD-22	RIM-27	LUG-17	BRACKET-25	098	
MTT1415	15"		X	HEAD-23	RIM-28	LUG-17	BRACKET-25	098	
FLOATUNE SERIES									
T11BK	13"		X	HEAD-24	RIM-21	LUG-17		098	
T11BK	14"		X	HEAD-22	RIM-22	LUG-17		098	
ARTIST SERIES, AMADITO VALDÉS									
AV1BK	14"		X	HEAD-22	RIM-27	LUG-17		098	
AV1BK	15"		X	HEAD-23	RIM-28	LUG-17		098	
ARTIST SERIES, LUIS CONTE									
LC1BRASS	14"	X	X	HEAD-22	RIM-19	LUG-16	BRACKET-08 brass	099	
LC1BRASS	15"	X	X	HEAD-23	RIM-20	LUG-16	BRACKET-09 brass, small	099	
LC1STS	14"	X	X	HEAD-22	RIM-19	LUG-16	BRACKET-10 chrome	099	
LC1STS	15"	X	X	HEAD-23	RIM-20	LUG-16	BRACKET-11 chrome, small	099	
PROFESSIONAL SERIES									
BT1415	14"	X		HEAD-22	RIM-19	LUG-16	BRACKET-10 chrome	099	
BT1415	15"	X		HEAD-23	RIM-20	LUG-16	BRACKET-11 chrome, small	099	
DRUMMER SNARE TIMBALES									
MDST8BK	8"		X	HEAD-41	RIM-29	LUG-21	BRACKET-13	102	
MDST10BK	10"		X	HEAD-42	RIM-30	LUG-21	BRACKET-13	102	
DRUMMER TIMBALE									
MDT13CH	13"		X	HEAD-43	RIM-31	LUG-21	BRACKET-13	102	
MINI TIMBALES									
MIT810CH	8"		X	HEAD-41	RIM-29	LUG-21	BRACKET-13	102	
MIT810CH	10"		X	HEAD-42	RIM-30	LUG-21	BRACKET-13	102	
ARTIST SERIES, TAKU HIRANO, HAND-BALE									
MHT13	13"		X	HEAD-43	RIM-47	LUG-21	BRACKET-13	103	
ARTIST SERIES, DAVE MACKINTOSH, ATTACK TIMBALE									
MDT88	8"		X	HEAD-41	RIM-48	LUG-21	BRACKET-13	103	

REPLACEMENT PARTS FOR STANDS	
Timbale Stand, chrome	TMT
Cowbell Holder, complete for MEINL Timbales	STAND-01
Cowbell Holder, complete for HT1314 Timbales	HDSTAND-01
Memory Clamp, chrome for middle stand tube	STAND-07
Memory Clamp, black for middle stand tube	STAND-08
Memory Clamp, chrome for lower stand tube	STAND-09
Memory Clamp, black for lower stand tube	STAND-10
Fast Lock Set, chrome	STAND-14
Fast Lock Set, black	STAND-15
Rubber Feet (set of 3 pcs.) for Timbales Stand	STAND-16

OTHER PARTS	
Lug Oil	SPARE-09
Tuning Key, 13 mm + 14 mm, L shaped, chrome	KEY-02



MEINL REPLACEMENT PARTS

Model No.	Size	Material										Features										REPLACEMENT PARTS				Page															
		Hardwood	Aluminum	Premium Fiberglass	Rubber Wood	Poplar Wood	ABS	Steel	Counter sunk bolt heads	Replaceable synthetic heads	Replaceable goat heads	Replaceable nappa heads	Height adjustable legs	Steel snare wires	Floatune Tuning System	Head	Rim	Lug	Bracket																						
SAMBA																																									
TRADITIONAL ALUMINUM & WOOD SURDOS																																									
SU16	16"	X	X						X	X																															
SU18	18"	X	X						X	X																															
SU20	20"	X	X						X	X																															
SU22	22"	X	X						X	X																															
TRADITIONAL STAND ALONE ALUMINUM & WOOD SURDOS																																									
SU16-L	16"	X	X						X	X			X																												
SU18-L	18"	X	X						X	X			X																												
SU20-L	20"	X	X						X	X			X																												
SU22-L	22"	X	X						X	X			X																												
BAHIA ALUMINUM SURDOS																																									
SUB18	18"		X						X	X																															
SUB20	20"		X						X	X																															
SUB22	22"		X						X	X																															
BAHIA WOOD SURDOS																																									
SUB18AB-M	18"	X							X	X																															
SUB20AB-M	20"	X							X	X																															
SUB22AB-M	22"	X							X	X																															
ALUMINUM CAIXAS																																									
CA12	12"		X						X	X			X																												
CA14	14"		X						X	X			X																												
TRADITIONAL ALUMINUM CAIXA																																									
CA12T	12"		X						X	X			X																												
ALUMINUM REPINQUES																																									
RE10	10"		X						X	X																															
RE12	12"		X						X	X																															
WOOD REPINIQUE																																									
RE12AB-M	12"			X					X	X																															
TIMBAS																																									
TIM14	14"				X				X																																
TANTAM																																									
TAN14	14"				X							X																													
REBOLO																																									
REB12	12"				X							X																													
ALUMINUM CUICAS																																									
QW6	6"		X									X																													
QW10	10"		X						X	X																															
FIBERGLASS CUICA																																									
QW7	8"			X								X		X																											
TAMPEIRO																																									
TP06AB-M	6"			X					X	X	X																														
SILENT TAMBORIM																																									
STBR06	6"								X																																
FLOATUNE TAMBORIMS																																									
TBR06	6"		X	X	X	X	X	X					X																												
OTHER PARTS																																									
A Go Go Bell Holder												STBAGH																													
Tuning Key												KEY-08																													
Tuning Key for Caixa												KEY-09																													
Tuning Key for Surdo and Repinique												KEY-10																													
Beater for Samba Triangle												SPARE-30																													
Nappa Heads for Surdo												HEAD-66 = 16" / HEAD-67 = 18" / HEAD-68 = 20" / HEAD-69 = 22"										110																			
Mesh Head for Tamborims												HEAD-79										115																			



DISCLAIMER

All features are subject to change without notice. Not responsible for typographic errors. No part of this book may be reprinted, reproduced, or included in any online service in any form in whole or in part, without the prior permission of MEINL.

© 2013 Roland Meinl Musikinstrumente GmbH & Co. KG

ADVERTISING
CONCEPT & DESIGN BY:

Marcus Beloch, Matthias Mautner
www.ercasdieagentur.de

CONTENT & DIRECTION BY:
Udo Heubeck, Mario Schmitt

MEINL WOULD LIKE TO THANK:
Christian Habermeier, Sebastian Jäger
www.studio-waldeck.de
Sven Mihm
www.mihm-werbung.de

MEINL GLOBAL HEADQUARTERS
Am Bahnhof 2
91468 Gutenstetten
Germany

MEINL USA L.C.
3300 Ambrose Avenue
Nashville, TN 37207
USA

This catalogue has been printed on
FSC certificated paper
Printed in Germany M-CA501212



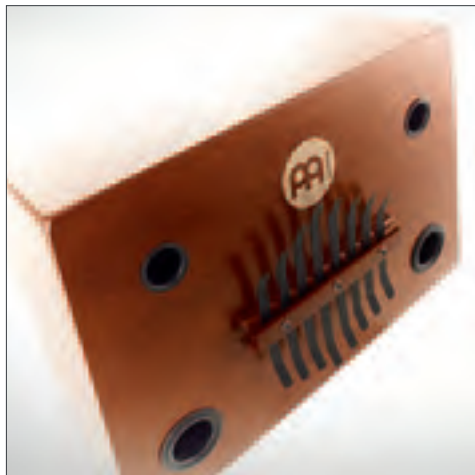

meinlpercussion.com