



Yamaha Strings
SILENT™ SERIES

SILENT *Violin*

SILENT *Viola*

SILENT *Cello*

SILENT *Bass*





As long as strings evoke passion,
the Silent Series will continue to evolve.





Original Yamaha musical instrument technology and craftsmanship, cultivated and refined over 120 years, are devoted to bringing the dreams of music lovers everywhere to life.

The evolution is ongoing, with traditional acoustic quality and the latest technology seamlessly blended in ways that enrich both player and listener. The Yamaha Silent Series offers unprecedented performance potential to all dedicated string players.

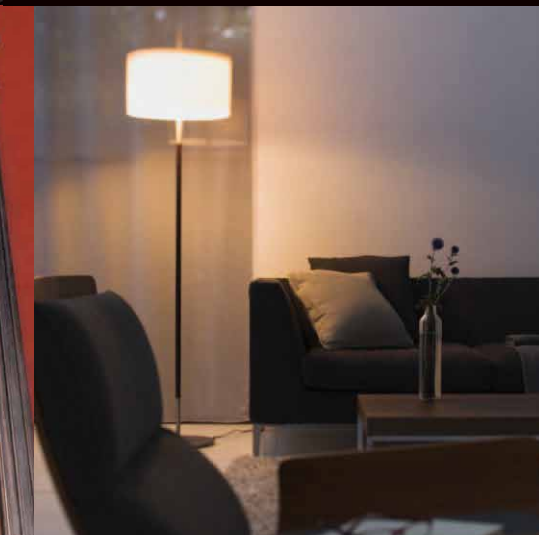

BREAK THE SILENCE

Vibrant expression that breaks with tradition and
preeminent quality demanded by professional musicians.

Yamaha SILENT Violin™ invites you to an
unprecedented live stage experience.



SV250 **New**

SV255 **New**



SV250



SV255

“The Yamaha SV250/255 is the best 4-string or 5-string electric violin I’ve ever played or heard. Ultra light and ultra durable, with incredible flexibility, it achieves a beautiful “acoustic” sound while also enabling me to work with effects smoothly and effortlessly. It’s even easier to play than an acoustic violin, allowing me to glide over passages that once seemed difficult.”

-Christian Howes



Acoustic Violin Weight and Balance

At 500 and 540 grams, respectively, the 4-string SV250 and 5-string SV255 are about the same weight as many of their acoustic counterparts. Furthermore, the tailpiece, neck, and tuning pegs on both models are exactly the same as those used on acoustic violins. Precision construction and meticulous attention to every detail mean total satisfaction for the most discerning player. Most standard shoulder rests can be used.

Dedicated Control Box Offers Easy Control and Connectivity

The dedicated control box offers easily accessible volume and two-band tone control, clipped to the player’s belt or to another convenient location. It also features a headphone monitor output with independent volume control. In addition to a line out jack that’s suitable for sending the Silent Violin signal to an amplifier or effect unit, a balanced XLR type output is provided for direct, high-quality connection to professional sound reinforcement and recording equipment.



* The control box is for use with the SV250 or SV255 only. It cannot be used with other Silent Violin models.

5-string SV255 Model for Broad Performance Potential

The 5-string SV255 has a “C” string pitched a fifth below the “G” string, offering wide-range, dynamic performance potential for jazz, pop, and a variety of other musical genres.

Two Pickup Types Add Up to Expressive Freedom

Yamaha’s acclaimed body pickup faithfully captures the rich resonance of the instrument’s entire body, as well as vibrato and other performance nuances. A second newly developed bridge pickup directly captures string vibration so that attack and bowing subtleties are accurately reproduced as well. A pickup blend control allows optimum balance between pickups.



New Body Design Achieves Natural Sound and Playability

The “Acoustic Hollow Body Design” so highly regarded in the SVC110 Silent Cello and SLB200 Silent Bass has been adapted and optimized for refined violin sound and playability in the SV250 and SV255. The result is a deep resonance that is remarkably close to acoustic violins in quality, as well as a familiar, intimate playing feel. An exquisite shaded finish brings out the beauty of the natural wood grain.

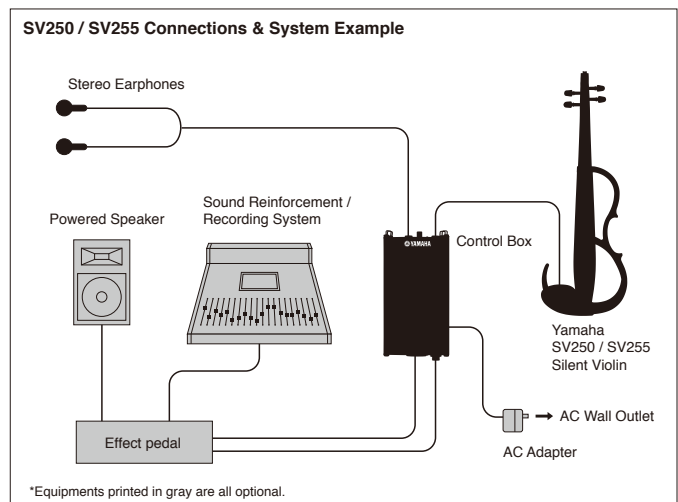
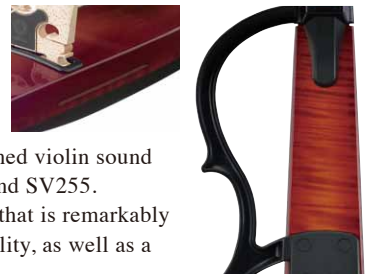

The SV200 offers easy feedback-free amplification, effects, silent practice and more, with superb tone that approaches the quality of a high-quality acoustic violin. This is a perfect performance instrument for any venue.

SV200



SV200 Ocean Blue



SV200 Black



SV200 Cardinal Red



SV200 Brown



“The Yamaha Silent Electric Violin rocks. I have used it for years and it keeps getting better. It’s the only electric violin that sounds great clean and still has the flexibility to be processed for use with multiple effects.”

-Christian Howes

Dual Pickups Deliver Greater Dynamic Range

The SV200’s dual pickup system delivers double resolution and expanded dynamic range. The pickups respond to subtle nuances making it easy to play with full expression, from pianissimo to fortissimo.

Special EQ Control

A special circuit isolates and controls the instrument’s upper harmonics, providing broad flexibility to adjust for individual playing styles, room acoustics, and amplification equipment, while closely approaching the tone of an acoustic violin.



Perfect Playability

The SV200’s oval-shaped neck features a thin layer of specially formulated finish that feels identical to that of an acoustic violin, and the frame extends past the chin rest to accommodate most standard chin/shoulder rests. The line out jack is positioned so the cord can be draped over the performer’s shoulder where it is out of the way.



In addition to weighing no more than an acoustic violin, the SV150 features refined circuitry that delivers lifelike violin tone plus a selection of 24 top-quality digital effects. A built-in digital tuner, metronome, and digital audio playback capability further add to the appeal of this outstanding instrument.

SV150



SV150 Black Sparkle



SV150 Brown



SV150 Wine Red



SV150S The outfit model of the SV150 that comes with the SV150, a soft case VSC3B, a carbon fiber bow, and a rosin.



Ideal Violin Weight & Separate Control Box

An unprecedented weight of only 490 grams places SV150 playability in the acoustic violin league. Connection to the separate control box is made via a thin, flexible cable.



24 Effects Deliver New Sonic Dimensions

In addition to ambience effects that simulate a number of acoustic environments, the SV150 offers a dazzling array of delay, modulation, pan, wah, distortion, and other effect variations ranging from subtle to wild.

Integrated Digital Audio Player, Tuner, & Metronome

An SD memory card containing digital music files can be plugged directly into the SV150 control box for play-along practice or listening, without the need for an external player. There's also a built-in tuner and metronome, so everything you need is right at your fingertips.

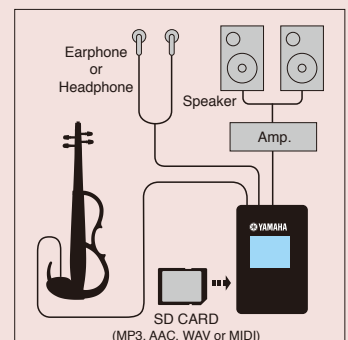

The SV130 allows violinists of all levels to practice almost anywhere, anytime, without disturbing others. Although the acoustic sound is barely a whisper, you'll hear yourself in a rich, resonant "virtual" concert hall.

SV130/130S



SV130 Black



SV130 Navy Blue



SV130 Brown



SV130 Candy Apple Red



SV130S

The SV130S supplies nearly everything you need to get started.

Acoustic Violin Playability with Silent Series Privacy

A specially designed solid body reduces acoustic output to a mere whisper, while the player experiences the uncompromised feel and playability of a high-quality violin. Plug in the earphones and practice anywhere, anytime.

Spacious Reverb

An original Yamaha chip supplies rich, spacious reverb that effectively simulates a stage environment for the player and listeners. Three variations are provided: Large Hall, Medium Hall, and Room.



Versatile Connections

Playing along with your favorite recordings can be inspiring, great practice, and just plain fun. The SV130 and SV130S make play-along practice easy with a line input jack and independent level control.

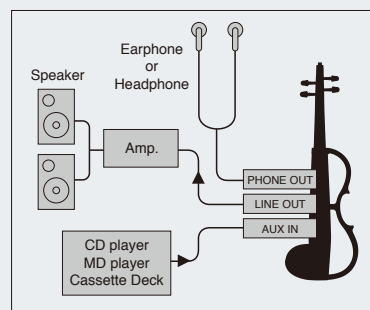

The SVV200 features a unique blend of tradition and technology: the advantages of an electric instrument with almost acoustic playability and sound. It's "silent" so you can practice anywhere at anytime. But it also shines in the studio or on stage.

SVV200



Advanced Electronics

Noise-free circuitry optimized for compatibility with professional audio gear makes the Silent Viola an ideal choice for studio or stage. The built-in EQ can be bypassed when you want to take advantage of high-end outboard equalization equipment.

Full-size Frame

Violists will immediately feel comfortable with the Silent Viola's standard 16" scale and full-size frame. The all-wood matte black frame has a natural feel, and can accommodate most standard chin/shoulder rests.



Dual Pickups Deliver Greater Dynamic Range

The Silent Viola's dual pickup system delivers double resolution and expanded dynamic range. The pickups respond to subtle nuances making it easy to play with full expression, from pianissimo to fortissimo.

Special EQ Control

A special circuit isolates and controls the instrument's upper harmonics, providing broad flexibility to adjust for individual playing styles, room acoustics, and amplification equipment, while closely approaching the tone of an acoustic viola.



The SVC110 was created in cooperation with some of the world's greatest cellists – a fact that is reflected in its extraordinary warm tone and playability. Players will appreciate the instrument's expressive capability and comfort, as well as its capacity for "silent" practice.

SVC110



These two models offer slim styling with folding (SVC210) or removable (SVC50) leg supports for maximum portability. They also deliver rich, expressive cello tone.

SVC210



Outstanding Tone Plus Spacious Reverb

The uniqueness of the Silent Cello lies in its ability to place naturally full-bodied, nuanced tone in a rich, simulated concert hall acoustic environment without the need for external signal processing. An original Yamaha chip delivers eminently natural, warm reverb in three variations: Large Hall, Medium Hall, and Room.

Exquisite Sound and Appearance

The SVC110 and SVC210 feature a hollow body with newly designed pickups for astonishingly natural, acoustic-like cello tone. A narrow aperture underneath the top board enhances the instrument's acoustic warmth with definition that works well amplified. A new finish highlights the beauty of the wood, matching the instrument's looks to its superlative sound.



Play Along, Connect to a Sound System

In addition to its many other features the Silent Cello has an auxiliary input as well as line and headphone outputs. Connect an external source to the auxiliary input and play along, and/or connect the line output to an external sound system for live performance. The headphone jack supports private practice with lush reverb effects.

“These instruments have incredible potential. Although first developed for use as a practice instrument, they have opened a new door of possibilities for the cello by the use of electronic technology. And the SVC110 has gone a step further by adding more power and depth to the sound. I enjoy performing with this musical instrument and am challenging musical audiences worldwide to open their minds to a future of new sounds from the cello.”

-David Geringas



SVC50



Compact Form

The sleek SVC210 and SVC50 fold or disassemble to fit in a compact carrying case for easy transportation. The SVC210 has folding legs and removable chest and arm supports. The SVC50's leg supports can be easily removed from the instrument body. Both instruments offer fast, fuss-free setup, and in their performance configuration provide the player with a natural comfort and excellent support.



SVC210

SVC50

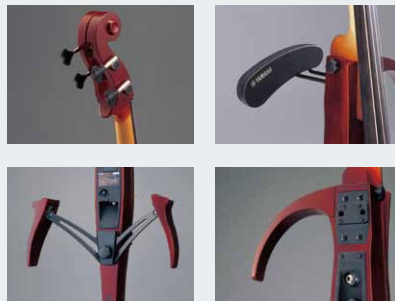

Standard Soft Case



for SVC210

for SVC50

for SVC110



The SLB200 is a lightweight, compact, performance-oriented bass with a hollow body and internally mounted pickup system that affords outstanding tone and solid, natural pizzicato response that makes it an ideal choice for jazz or popular genres. Plug-and-play electronics combine with acoustic bass style playability for extraordinary versatility.

SLB200



"When I'm looking for that 'Upright' sound, I reach for my Silent Bass. The sound quality is rich and full and the feel is very comfortable. In my arsenal of basses, my SLB200 has become an important instrument for live gigs as well as in the studio."

-Nathan East

Detachable Frame for Convenience and Portability

Both the SLB200 and SLB100 feature frames that provide excellent support and comfort while playing, but can be easily detached for convenient storage and transportation. The SLB200 fits in a compact case that can be comfortably carried with a shoulder strap.



SLB200 Soft case

Straightforward Controls

Volume, bass, and treble controls on the SLB200 combine with active electronics to allow versatile plug-and-play operation without the need for external pre-amplification. The SLB100 has volume and tone controls, plus an independent volume control for the AUX IN jack.



“Yamaha has always been synonymous with highest quality and consistency. Having played my beloved instruments for all these years, I know first hand how they never rest on their laurels, always seeking to improve, with great success. Their support throughout the world and their unsurpassed craftsmanship has made them an important part of my everyday life as a musician.”
 -Chris Minh Doky

SILENT *Bass*™

In addition to its superb tone and suitability for a wide range of musical styles, bassists will appreciate the SLB100's silent practice capability that delivers inspiring time through a pair of headphones.

SLB100



Optional Supports



Extension Frame BEF2 for SLB200



Knee Support BKS2 for SLB200



Knee Support BKS1 for SLB100



Stand BST1

Standard Soft Case



for SLB200

Optional Soft Case



for SLB100

VNP1 Violin Bridge Pickup System

The VNP1 is an ideal amplification solution for acoustic violinists who want full tonal response with maximum feedback resistance under the widest possible range of acoustic conditions.

This fully grounded dual-sensor pickup is installed in an Aubert bridge blank connected to a side-mounted jack that will not interfere with the shoulder rest.



Accessories

VSC3 Silent and Electric Violin Soft Case

Color: Black / White
The Stylish soft case comes in two colors, Ivory White with gray stitch or Black with red stitch. Designed to be carried with the handle or the shoulder strap. An external bow case is detachable.



PA-D05 AC Power Adapter

For Silent Violin SV150.



PA-3C AC Power Adapter

Compatible for
Silent Violin SV130,
Silent Cello SVC50,
SVC110, SVC210,
and Silent Bass SLB100.



Carbon Bows

Standard Bows



Signature Series

Zakhar Bron

One of the world's most respected and preeminent violin professors and soloists, Zakhar Bron is the mentor of such great violinists as Vadim Repin, Maxim Vengerov, Daishin Kashimoto, and Tamaki Kawakubo. Bron is very particular when it comes to bow performance and his collaboration with Yamaha manufacturing expertise has resulted in the Zakhar Bron signature bow.



CBB107ZB Artist Signature Series



Bows Specifications

Model	Stick		Grip	Winding	Frog		Button		Weight	Balance	
	Material	Color			Material	Eye (Ring)	Metal	Core			
Violin 4/4	CBB101	Carbon Fiber	Black	Leather/Black	Silver Plate	Ebony	Pearl (Nickel)	Nickel	Plastic	Standard	Standard
	CBB103	Carbon Fiber	Black	Leather/Black	Silver Décor	Ebony	Abalone (Silver)	Silver	Ebony	Standard	Standard
	CBB105	Carbon Fiber	Black	Leather/Black	Silver Décor	Ebony	Abalone (Silver)	Silver	Abalone Inlaid Ebony	Standard	Standard
Viola 4/4	CB202	Carbon Fiber	Black	Leather/Black	Silver Plate/Décor	Ebony	Pearl (Nickel)	Nickel	Plastic	Standard	Standard
	CB205	Carbon Fiber	Black	Leather/Black	Silver/Décor	Ebony	Abalone (Silver)	Silver	Abalone Inlaid Ebony	Standard	Standard
Cello 4/4	CBB301	Carbon Fiber	Black	Leather/Black	Silver Plate	Ebony	Pearl (Nickel)	Nickel	Plastic	Standard	Standard
	CBB305	Carbon Fiber	Black	Leather/Black	Silver/Décor	Ebony	Abalone (Silver)	Silver	Abalone Inlaid Ebony	Standard	Standard
Violin Signature Models	CBB107ZB Zakhar Bron	Carbon Fiber	Black	Leather/Black	Gold Brass/Décor	Ebony	Abalone (Gold)	Gold Brass	Abalone Inlaid Ebony	Slightly heavy	Tip

*Specifications and design subject to change without notice.

specifications

	Silent Violin						Silent Viola	
	SV250	SV255	SV200	SV150	SV150S	SV130	SV130S	SVV200
Body Color	Brown		Brown Black Cardinal Red Ocean Blue	Brown Black Sparkle Wine Red		Brown Navy Blue Black Candy Apple Red		Brown
Size	4/4						16" (406mm)	
Neck	Spruce/Maple			Maple		Maple		
Body	Spruce/Maple			Spruce		Spruce		
Frame	Plastic						Plywood	
Finger Board	Ebony						Ebony	
Tuning Pegs	Ebony			Maple (Aubert)		Ebony & Rosin Hybrid		
Bridge	Ebony			Maple (Aubert)		Maple (Aubert)		
Tailpiece	Wittner Ultra		Ebony	Wittner Ultra		Plastic		Ebony
Fine Tuner	4 (each string)	5 (each string)	1 (E-string)	4 (each string)		4 (each string)		1 (A-string)
Chin Rest	Plastic		Ebony	Plastic		Plastic		Ebony
Sensor	2 Piezo Pickups (body and bridge)		2 Piezo Pickups	Piezo Pickup		Piezo Pickup		2 Piezo Pickups
Electric Controls	Pick up Blend		Volume EQ Mode Switch EQ Control	Volume		Volume Aux-In Volume Reverb SW (ROOM/HALL1/HALL2)		Volume EQ Mode Switch EQ Control
Control Box	Line Out Volume, Treble, Bass, Headphone Volume, Grand Lift Switch, Balanced Out, PAD Switch		—	Volume/mute, Hold, Mode (Player, Sound, Tuner, Metronome)		—		—
In/Out Jacks	Phones Out Line Out Balanced Out		Phones Out Line Out	Phones Out Line Out SD card slot		Phones Out Line Out Aux In		Phones Out Line Out
Power Supply	AA size 1.5V battery 2pcs. or AC adapter (optional)		9V battery 1pc.	AA size 1.5V battery 2pcs. or AC adapter (optional)		AA size 1.5V battery 2pcs. or AC adapter (optional)		9V battery 1pc.
Battery Life* Manganese Alkaline	approx. 15~45 hrs approx. 50~120 hrs.		approx. 5 hrs approx. 12 hrs.	maximum 2 hrs maximum 10.5 hrs.		approx. 4~20 hrs approx. 12~60 hrs.		approx. 5 hrs approx. 12 hrs.
Weight	500g (1 lbs. 1 oz)	540g (1 lbs. 1 oz)	620g (1 lbs. 6 oz)	490g (1 lbs. 1 oz) (control box) 85g (3 oz)		650g (1 lbs. 7 oz)		740g (1 lbs. 10 oz)
Standard Accessories	Control Box, Connection Cable, Cable bands, Earphone, AA size 1.5V battery 2pcs.		Earphone 9V battery 1pc.	Control Box, SD card, Music Book, Earphone, Audio Cable, AA size 1.5V battery 2pcs.		Earphone, Audio Cable AA size 1.5V battery 2pcs., Shoulder Rest		Earphone 9V battery 1pc.
				—	Soft Case VSC3B, Carbon Fiber Bow, Rosin	—	Hard case, Carbon Fiber Bow, Rosin	

	Silent Cello			Silent Bass	
	SVC110	SVC210	SVC50	SLB200	SLB100
Size	4/4			String Length 1,040mm (41")	String Length 1,054mm (41-1/2")
Neck	Maple			Maple	
Body	Spruce/Maple		Alder	Spruce/Mahogany	
Frame	Plywood	—	—	Beech (Detachable)	
Knee Supports	—	Beech (Folding Type)	Beech (Detachable)	—	
Finger Board	Ebony			Rosewood	
Tuning Pegs	Ebony	Worm Gear Type		Custom Worm Gear Type	
Bridge	Maple (Aubert)	Maple (PANFI)		Maple (Height Adjustable)	
Tailpiece	Wittner Ultra	Wittner	Ebony	Ebony (Reverse type)	Ebony
Fine Tuner	4 (each string)		—	—	
Sensor	Piezo Pickup			Piezo Pickup	2 Piezo Pickups
Electric Controls	Volume Aux-In Volume Reverb Switch (RM/HL1/HL2)			Volume Treble Bass	Volume Tone control Aux-In Volume
In/Out Jacks	Phones Out, Line Out, Aux-In			Line Out	Phones / Line Out, Aux In
Power Supply	AA size 1.5V battery 2pcs. or AC adapter (optional)			9V battery 1pc.	9V battery 1pc. or AC adapter (optional)
Battery Life* Manganese Alkaline	approx. 3~10 hrs. approx. 9~25 hrs.		approx. 2.5~15 hrs. approx. 10~35 hrs.	approx. 350 hrs. approx. 500 hrs.	approx. 12 hrs. approx. 24 hrs.
Weight	3.7kg (8 lbs. 2 oz)	3.9kg (8 lbs. 2 oz)	3.5kg (7 lbs. 11 oz)	7.2kg (15 lbs. 14 oz)	10kg (22 lbs.)
Standard Accessories	Stereo Headphones, Audio Cable Chest Support, AA size 1.5V battery 2pcs. Soft case			Soft case 9V battery 1pc.	9V battery 1pc.

* The battery life will vary depending on the quality of the batteries, or the use of reverb, headphones, etc.
* All specifications subject to change without notice.



For details please contact: